



Separate Type Absolute Linear Scale

ABS ST700/ST700L (Compact) Series

User's Manual - Instructions for use -

Read this User's Manual thoroughly before operating the instrument. After reading, retain it close at hand for future reference. This English language version of the User's Manual contains the original instructions.

No. 99MBE073B2
Date of publication: February 1, 2020 (1)



■ Correspondence of product names and model numbers

Product name	Model number
Separate Type Absolute Linear Scale	ABS ST7*8/ABS ST7*8L

■ Notice regarding this guide





- Mitutoyo Corporation assumes no responsibilities for any damage to the product, caused by its use not conforming to the procedure described in this User's Manual.
- Upon loan or transfer of this product, be sure to attach this User's Manual to the product.
- In the event of loss or damage to this manual, immediately contact a Mitutoyo sales office or your dealer.
- Before operating this product, thoroughly read this manual to comprehend its contents.
- Particularly, for full understanding of information, carefully read "Safety Precautions" and "Precautions for Use" at the outset of this manual before using the product.
- The contents in this manual are based on the information current as of February, 2020.
- No part or whole of this manual may be transmitted or reproduced by any means without prior written permission of Mitutoyo Corporation.
- The corporation, organization and product names that appear in this manual are their trademarks or registered trademarks.

©2018-2020 Mitutoyo Corporation. All rights reserved.



Conventions Used in Manuals

Conventions used in this User's Manual are roughly divided into three types (safety reminders, prohibited actions/mandatory actions, referential information/referential locations). Moreover, these safety symbols include general warnings and specific warnings. Specific warning symbols are provided with concrete pictograms inside of them.

■ Safety reminder conventions and wording warning against potential hazards

 DANGER	Indicates an immediately hazardous situation which, if not avoided, will result in serious injury or death.
 WARNING	Indicates a potentially hazardous situation which, if not avoided, could result in serious injury or death.
 CAUTION	Indicates a potentially hazardous situation which, if not avoided, may result in minor injury.
 NOTICE	Indicates a potentially hazardous situation which, if not avoided, may result in property damage.
	Alerts the user to a specific hazardous situation that means "Caution, risk of electric shock".

■ Conventions and wording indicating prohibited and mandatory actions

	Indicates concrete information about prohibited actions.
	Indicates concrete information about mandatory actions.
	Indicates that grounding needs to be implemented.

■ Conventions and wording indicating referential information or referential locations

Tips Indicates reference and other information to use when applying the operation method or procedure described in the text to specific conditions.



Indicates referential locations if there is information that should be referred to in this document or an extraneous manual.

E.g.: For further details on xxx, refer to  "1.2 System Configuration and Part Names" (page 2)

Safety Precautions

Observe the following descriptions to make full use of the performance of this product:

NOTICE

- Read this User's Manual thoroughly before operating this product.
- Before connecting this product to the machine main unit, make sure that the power for the control unit is turned off.
- To maintain the shielding effect, firmly tighten the screws on the connectors of each connecting cable.
- To prevent defective contacts, do not touch the connecting terminals of the connectors with bare hands.

Precautions for Use

■ Application and handling of this product

- This product is a measurement instrument.
Do not use it for any other purpose than measurement.
- This product is an industrial product.
Do not use it for any other purpose than industrial use.
- This product is a precision instrument.
Use it with extreme caution. Do not apply impact or excessive force to the product's parts during operation.

■ Installation environments

● Vibration

To install this product onto a machine main unit, select a location where there is as little vibration as possible.

If the scale unit is used for an extended period of time on a machine where there is a substantial amount of vibration, the built-in precision parts may be damaged, thereby adversely influencing the performance of the unit.

● Shock, dust, water protection

To protect the scale unit from being directly exposed to machining oil and chips, or from being bumped by a workpiece, etc., prepare a cover that protects the entire unit.

● Ambient temperature and humidity

This product should be operated in an environment as shown below; however, avoid using it in a place where a sudden change in temperature or humidity can be observed.

Operating environment	(Effective measurement length : 3m or less)	(Effective measurement length : 3.2–6m)
	Temperature: 0 °C–50 °C Humidity: 20 %–80 % RH (non condensation)	Temperature: 0 °C–50 °C Humidity: 20 %–70 % RH (non condensation)

Electromagnetic Compatibility (EMC)

This product complies with the EMC Directive. Note that in environments where electromagnetic interference exceeds EMC requirements defined in this directive, appropriate countermeasures are required to ensure product performance.

EMC Directive EN61326-1

Immunity test requirement: Clause 6.2 Table 2

Emission limit: Class B

For the EU Directive

Authorized representative and importer in the EU:
Mitutoyo Europe GmbH
Borsigstrasse 8-10, 41469 Neuss, Germany

Export Control Compliance

This product falls into the Catch-All-Controlled Goods and/or Catch-All-Controlled Technologies (including Programs) under Category 16 of Appended Table 1 of the Export Trade Control Order or under Category 16 of the Appended Table of Foreign Exchange Control Order, based on the Foreign Exchange and Foreign Trade Act of Japan.

If you intend re-export of the product from a country other than Japan, re-sale of the product in a country other than Japan, or re-provision of the technology (including program), you are obligated to observe the regulations of your country.

Also, if an option is added or modified to add a function to this product, this product may fall under the category of List-Control Goods and/or List-Control Technology (including Programs) under Category 1 - 15 of Appended Table 1 of the Export Trade Control Order or under Category 1 - 15 of the Appended Table of Foreign Exchange Control Order, based on Foreign Exchange and Foreign Trade Act of Japan. In that case, if you intend re-export of the product from a country other than Japan, re-sale of the product in a country other than Japan, or re-provision of the technology (including program), you are obligated to observe the regulations of your country. Please contact Mitutoyo in advance.

Notes on Export to EU Member Countries

When you intend to export this product to any of the EU member countries, you may be required to provide User's Manual(s) in English and EU Declaration of Conformity in English (under certain circumstances, User's Manual(s) in the destination country's official language and EU Declaration of Conformity in the destination country's official language). For detailed information, please contact Mitutoyo in advance.

Disposal of Products outside the European Union and other European Countries

Please follow the official instruction in each community and country.

Disposal of Old Electrical & Electronic Equipment (applicable in the European Union and other European countries with separate collection systems)



This symbol on the product or on its packaging is based on WEEE Directive (Directive on Waste Electrical and Electronic Equipment), which is a regulation in EU member countries, and indicates that this product shall not be treated as household waste.

■ To reduce environmental impact and minimize the volume of landfill, please cooperate in reuse and recycling.

For information on how to dispose of the product, please contact your dealer or the nearest Mitutoyo sales office.

China RoHS Compliance Information

This product meets China RoHS requirements. See the table below.

产品中有害物质的名称及含量

部件名称	有害物质					
	铅	汞	镉	六价铬	多溴联苯	多溴二苯醚
	(Pb)	(Hg)	(Cd)	(Cr(VI))	(PBB)	(PBDE)
本体	○	○	○	○	○	○
电气设备部分	×	○	○	○	○	○
配件	○	○	○	○	○	○

本表格依据 SJ/T 11364 的规定编制。

○: 表示该有害物质在该部件所有均质材料中的含量均在 GB/T 26572 规定的限量要求以下。

×: 表示该有害物质至少在该部件的某一均质材料中的含量超出 GB/T 26572 规定的限量要求。



环保使用期限标识, 是根据电器电子产品有害物质限制使用管理办法以及, 电子电气产品有害物质限制使用标识要求(SJ/T11364-2014), 制定的适用于中国境内销售电子电气产品的标识。

电子电气产品只要按照安全及使用说明内容, 正常使用情况下, 从生产月期算起, 在此期限内, 产品中含有的有毒有害物质不致发生外泄或突变, 不致对环境造成严重污染或对其人身、财产造成严重损害。

产品正常使用后, 要废弃在环保使用年限内或者刚到年限的产品时, 请根据国家标准采取适当的方法进行处置。

另外, 此期限不同于质量/功能的保证期限。

Warranty

In the event that this product should prove defective in workmanship or material, within one year from the date of original purchase for use, it will be repaired or replaced, at Mitutoyo's option, free of charge upon its prepaid return to Mitutoyo, without prejudice to the provisions of the Mitutoyo Software End User License Agreement.

If this product fails or is damaged for any of the following reasons, it will be subject to a repair charge, even if it is still under warranty.

- Failure or damage owing to ordinary wear and tear
- Failure or damage owing to inappropriate handling, maintenance or repair, or to unauthorized modifications
- Failure or damage owing to transport, dropping, or relocation of the instrument after purchase
- Failure or damage owing to fire, salt, gas, abnormal voltage, lightning surge, or natural disaster
- Failure or damage owing to use in combination with hardware or software other than those designated or permitted by Mitutoyo
- Failure or damage owing to use in ultra-hazardous activities

This warranty is effective only where the instrument is properly installed and operated in conformance with the instructions in this manual within the original country of the installation.

EXCEPT AS SPECIFIED IN THIS WARRANTY, ALL EXPRESS OR IMPLIED CONDITIONS, REPRESENTATIONS, AND WARRANTIES OF ANY NATURE WHATSOEVER INCLUDING, WITHOUT LIMITATION, ANY IMPLIED WARRANTY OF MERCHANTABILITY, FITNESS FOR A PARTICULAR PURPOSE, NONINFRINGEMENT OR WARRANTY ARISING FROM A COURSE OF DEALING, USAGE, OR TRADE PRACTICE, ARE HEREBY EXCLUDED TO THE MAXIMUM EXTENT ALLOWED BY APPLICABLE LAW.

You assume all responsibility for all results arising out of its selection of this product to achieve its intended results.

Disclaimer

IN NO EVENT WILL MITUTOYO, ITS AFFILIATED AND RELATED COMPANIES AND SUPPLIERS BE LIABLE FOR ANY LOST REVENUE, PROFIT, OR DATA, OR FOR SPECIAL, DIRECT, INDIRECT, CONSEQUENTIAL, INCIDENTAL, OR PUNITIVE DAMAGES HOWEVER CAUSED AND REGARDLESS OF THE THEORY OF LIABILITY ARISING OUT OF THE USE OF OR INABILITY TO USE THIS PRODUCT EVEN IF MITUTOYO OR ITS AFFILIATED AND RELATED COMPANIES AND/OR SUPPLIERS HAVE BEEN ADVISED OF THE POSSIBILITY OF SUCH DAMAGES.

If, notwithstanding the foregoing, Mitutoyo is found to be liable to you for any damage or loss which arises out of or is in any way connected with use of this product by you, in no event shall Mitutoyo's and/or its affiliated and related companies' and suppliers' liability to you, whether in contract, tort (including negligence), or otherwise, exceed the price paid by you for the product only.

The foregoing limitations shall apply even if the above-stated warranty fails in its essential purpose. BECAUSE SOME COUNTRIES, STATES OR JURISDICTIONS DO NOT ALLOW THE EXCLUSION OR THE LIMITATION OF LIABILITY FOR CONSEQUENTIAL OR INCIDENTAL DAMAGES, IN SUCH COUNTRIES, STATES OR JURISDICTIONS, MITUTOYO'S LIABILITY SHALL BE LIMITED TO THE EXTENT PERMITTED BY LAW.

About This Document

■ Positioning of this document in document map

In addition to this document, a linear scale-related and a software-related manuals are available.

● Linear scale related

ABS ST700/ST700L (Compact) Series
User's Manual (this manual)

● Software related

ABS ST700/ST700L (Compact) Series
Signal Adjustment Program
User's Manual

ABS ST700/ST700L (Compact) Series
System Parameter R/W Program
User's Manual

■ Intended readers and purpose of this document

● Intended readers

This manual is intended for those who use the ABS ST700/ST700L (Compact) Series Separate Type Absolute Linear Scale for the first time.

This is also assumed to be able to understand individual instructions by reading screen displays.

● Purpose

This document is aimed at understanding of the ABS ST700/ST700L (Compact) Series Separate Type Absolute Linear Scale.

Contents

Conventions Used in Manuals	i
Safety Precautions	ii
Precautions for Use	ii
Electromagnetic Compatibility (EMC)	iii
Export Control Compliance	iii
Notes on Export to EU Member Countries	iii
Disposal of Products outside the European Union and other European Countries	iii
Disposal of Old Electrical & Electronic Equipment (applicable in the European Union and other European countries with separate collection systems)	iv
China RoHS Compliance Information	iv
Warranty	v
Disclaimer	vi
About This Document	vii
Contents	viii
1 Overview	1
1.1 Features	1
1.2 System Configuration and Part Names	2
1.3 Flow of Main Tasks	3
2 Setup for Installation	5
2.1 Checking the Equipment Model	5
2.1.1 System Parameters	6
2.1.2 Compatibility between the Scale Base and the Detector	6
2.2 Installation Conditions	7
2.2.1 Dust and Water Protection	7
2.2.2 Magnetism	7
2.3 Designing the Scale Installation Surface	8
2.3.1 Selecting the Material of the Scale Installation Part	8
2.4 Designing the Detector Bracket	9
3 Installation onto the Machine Main Unit	11

3.1	Checking the Package Contents	11
3.2	Installing the Scale Base	12
3.2.1	Checking after the Scale Base Installation	12
3.3	Installing the Detector Bracket and the Detector	13
3.3.1	Installing the Detector Bracket	13
3.3.2	Installing the Detector	13
3.4	Connecting the Cables	16
4	Specification	19
4.1	Specifications	19
4.2	Pin Assignment	21
4.2.1	ABS ST708A, ST708AL	21
4.2.2	ABS ST748A, ST748AL Mitsubishi Electric Corporation Specifications MELSERVO MR-J2	22
4.2.3	ABS ST748A, ST748AL Mitsubishi Electric Corporation Specifications MELSERVO MR-J3/MR-J4	22
4.2.4	ABS ST748, ST748L Mitsubishi Electric Corporation Specifications CNC Series DS-D, MDS-DH, MDS-Dn	23
4.2.5	ABS ST758, ST758L FANUC Corporation	23
4.2.6	ABS ST778A, ST778AL Panasonic Corporation	24
4.2.7	ABS ST788A, ST788AL Yaskawa Electric Corporation	24
4.3	Calculation of Feedback Cable Length	25
4.4	Dimensional Drawings	26
4.4.1	ABS ST700 (Compact) Series	26
4.4.2	ABS ST700L (Compact) Series	28
5	Troubleshooting	31
5.1	Alarm Function	31
5.1.1	Alarm Detections	31
5.1.2	LED Display on the Detector	32
5.2	Alarm Codes	33
5.2.1	ABS ST748A, ST748AL	33
5.2.2	ABS ST758, ST758L	34
5.2.3	ABS ST778A, ST778AL	36
5.2.4	ABS ST788A, ST788AL	38
	SERVICE NETWORK	App-1

1 Overview

This chapter describes the features of this product, names and functions of each part, and the flow of the main tasks to use this product.

1.1 Features

The linear scale will output a moving amount and displacement as digital amounts based on a linear scale graduated in certain fixed pitches.

This can precisely measure moving amounts of various instruments including electronic/semiconductor manufacturing units and machine tools.

This product is an absolute scale adopting the electromagnetic induction detection method. With non-contact detection, this is suitable for high-speed/high-acceleration control of linear motors. The Detector was compacted to about one third of a conventional head in volume, the cable outlet is selectable from four directions, and the installation holes are available in the top and side directions. In addition, the following interface specifications compatible with the high-speed serial interface of the companies are available.

- FANUC Corporation Specifications
- Mitsubishi Electric Corporation Specifications
- Yaskawa Electric Corporation Specifications
- Panasonic Corporation Specifications
- Mitutoyo Corporation ENSIS® Specifications

1.2 System Configuration and Part Names

The configuration and part names of the Linear Scale ABS ST700/ST700L (Compact) Series are shown below.

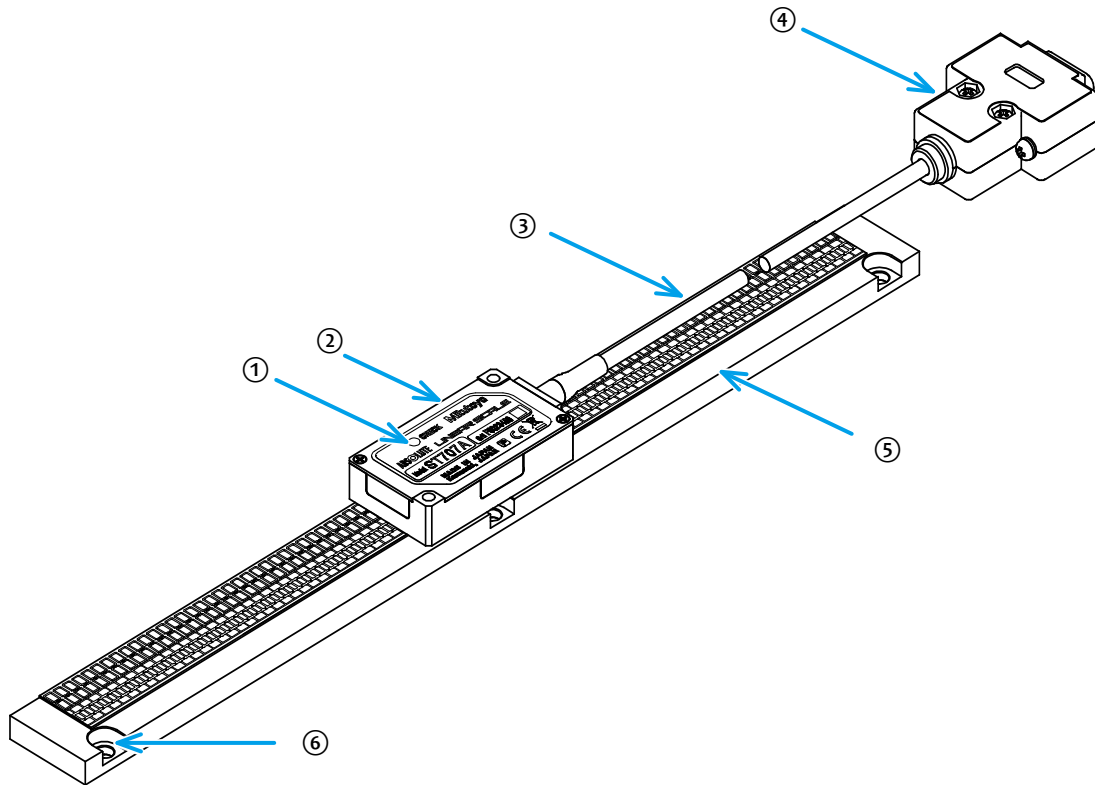
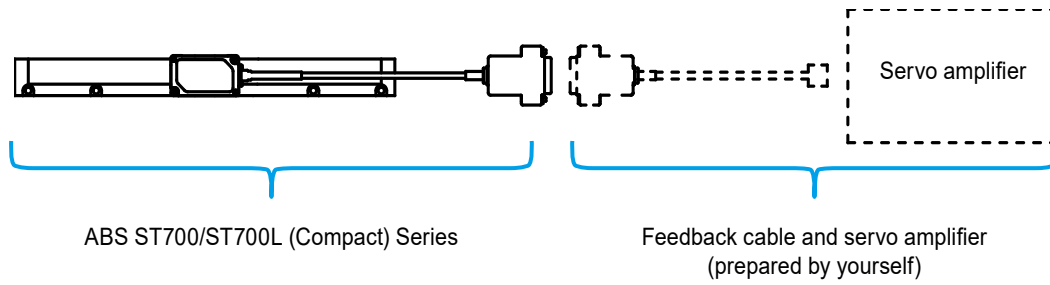

No.	Name
①	Power-on and alarm display LED
②	Detector
③	Detector cable (1 m)
④	Output connector
⑤	Scale base
⑥	Scale base installation screw countersunk hole

1.3 Flow of Main Tasks

The following chart shows the flow of preliminary preparation and installation onto the machine main unit as tasks to use this product.

■ Preliminary preparation

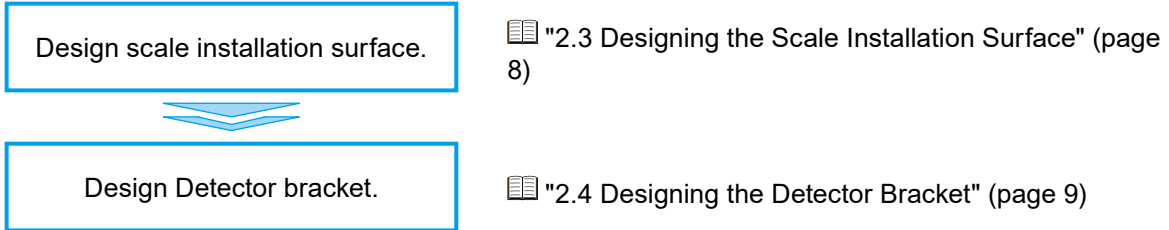

■ Installation onto the machine main unit

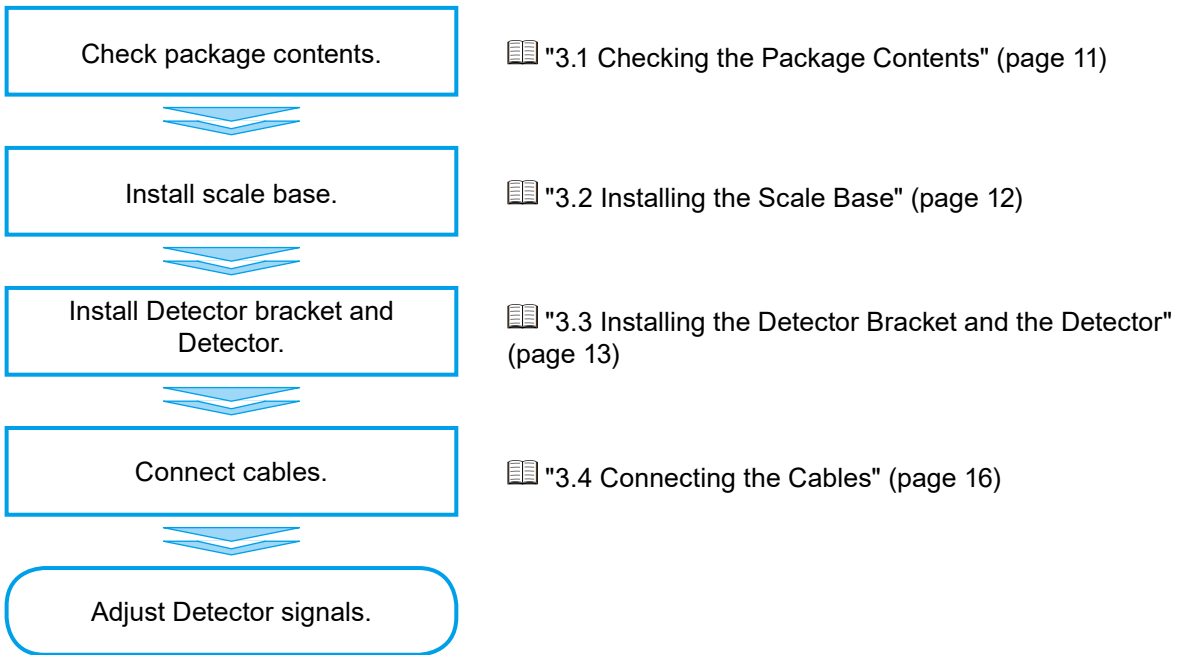

- After installing the scale unit, perform signal adjustment for the Detector according to "ABS ST700/ST700L (Compact) Series Signal Adjustment Program User's Manual". For details, refer to ■ "ABS ST700/ST700L (Compact) Series Signal Adjustment Program User's Manual" (No. 99MBE040B).
- Use a pair of scale base and Detector that have the same Serial No. attached on them.
- Signal adjustment for the Detector after scale unit installation requires a PC and peripheral equipment. Prepare necessary equipment according to Chapter 1 in "ABS ST700/ST700L (Compact) Series Signal Adjustment Program User's Manual".

MEMO

2 Setup for Installation

This chapter describes the preliminary preparation for installing this product onto the machine main unit.

2.1 Checking the Equipment Model

You can specify the Linear Scale ABS ST700/ST700L (Compact) Series with a model number according to the interface specifications, effective measurement length, and Detector cable outlet direction.

Check if your linear scale supports a servo amplifier you want to use.

ABS ST7 0 8 A L – 100 A – R

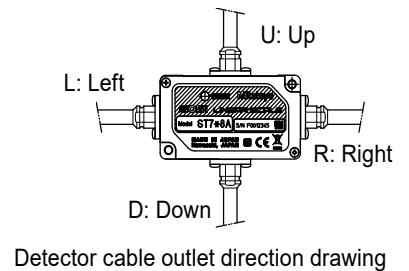
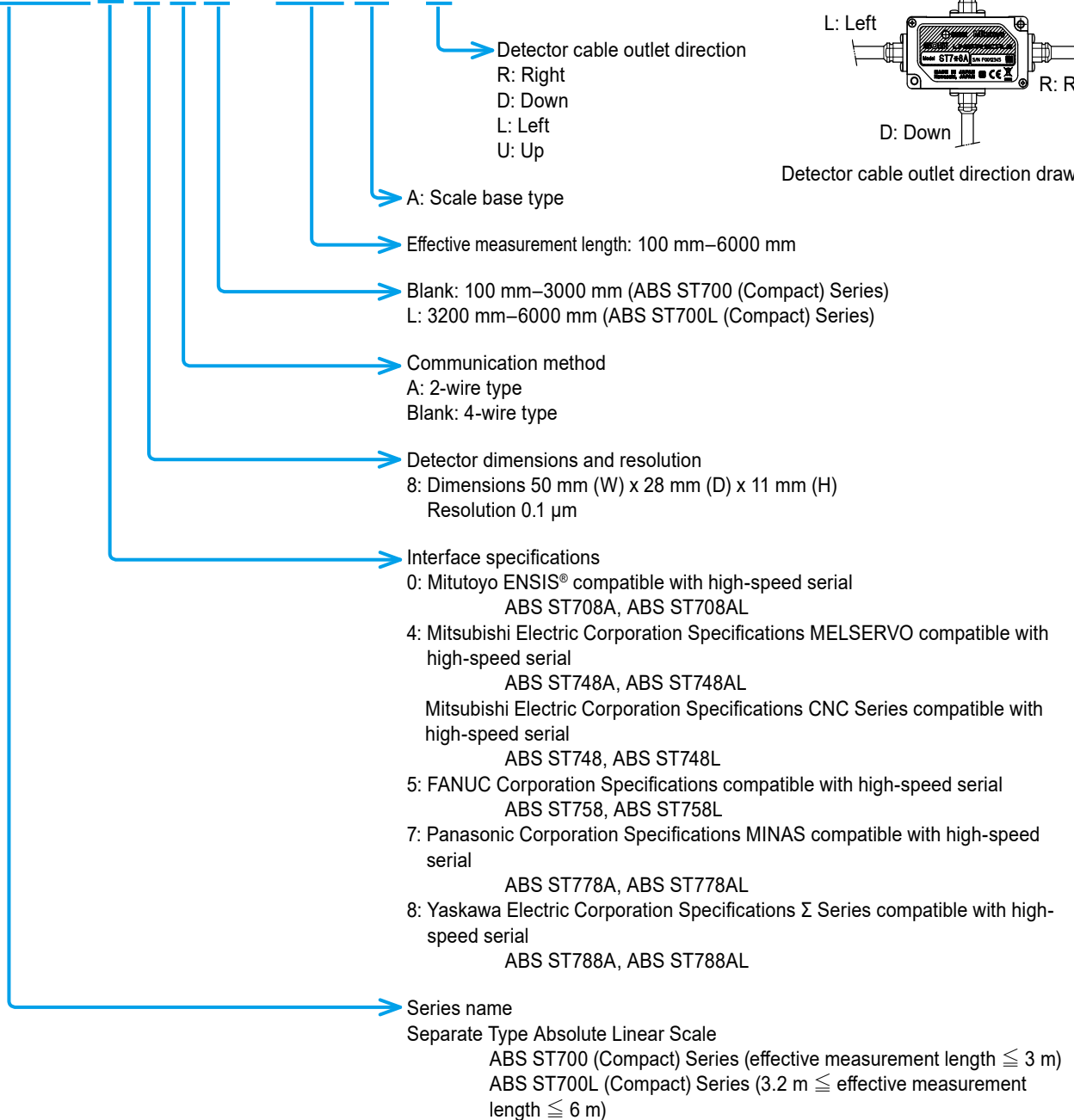

2.1.1 System Parameters

The Linear Scale ABS ST700/ST700L (Compact) Series is designed to be used with the system parameters (scale-specific parameters) written into the Detector. If the system parameter values are incorrect, therefore, the unit cannot fully achieve the predetermined performance.

Normally, a scale is supplied in a pair with a Detector into which the system parameters are already written, so using this factory-shipped pair does not cause any problems. However, if the Detector fails or another Detector is added later (such as when adding two or more Detectors later to one scale), you need to write the system parameters of the target scale into the Detector(s).



- For the following conditions, contact the nearest Mitutoyo office/service center:
 - When the Detector currently used is malfunctioning
 - When a Detector needs to be in stock as a backup for failure
 - When a Detector is added later
- If the scale currently used is damaged, you need to replace both the scale and the Detector.

2.1.2 Compatibility between the Scale Base and the Detector

There is no scale base compatibility between the ABS ST700 (Compact) Series and the ABS ST700L (Compact) Series because each uses a dedicated Detector.

Scale base	Connection possibility	Detector
ABS ST700 (Compact) Series (for effective measurement length: 3 m or less)		ABS ST700 (Compact) Series (for effective measurement length: 3 m or less)
ABS ST700L (Compact) Series (for effective measurement length: 3.2 m–6 m)		ABS ST700L (Compact) Series (for effective measurement length: 3.2 m–6 m)

2.2 Installation Conditions

2.2.1 Dust and Water Protection

The ABS ST700/ST700L (Compact) Series uses a sensor that is not affected by cutting fluid or dust, but it is not designed to keep dust from entering between the Detector and the scale base, so the product has no IP (International Protection) code.

A little amount of cutting fluid or dust attached on the scale does not restrict the functions, but the scale should not be exposed to the above environment as much as possible because a serious malfunction may occur if iron dust enters the inside.

Please also note that the detection part of the scale pattern or Detector may be damaged if you scan the unit when there is an about 0.4 mm-thick foreign object in a gap between the Detector and the scale base.



It is recommended to put a cover on the scale base and the Detector to prevent water, oil, and dust.

2.2.2 Magnetism

The Linear Scale ABS ST700/ST700L (Compact) Series uses a measurement sensor based on the electromagnetic induction method. Electromagnetic induction is a phenomenon where applying an electric current to one of two coils opposite to each other causes an electric flux on the target coil and induces an electric current on the other coil. By detecting an electric current induced according to displacement using this basic principle, the amount of displacement is determined. Therefore, in an environment where equipment (such as a linear motor) that generates strong magnetism is located near the scale, please note the following on installing the scale unit:

- It is recommended to install the scale unit in a location that is not affected by magnetism as much as possible.
- If you have no choice but to place the scale unit near the linear motor, select a location with magnetism of 3 mT or less.

2.3 Designing the Scale Installation Surface



Design the scale installation part as shown in the figure below according to "4.4 Dimensional Drawings".

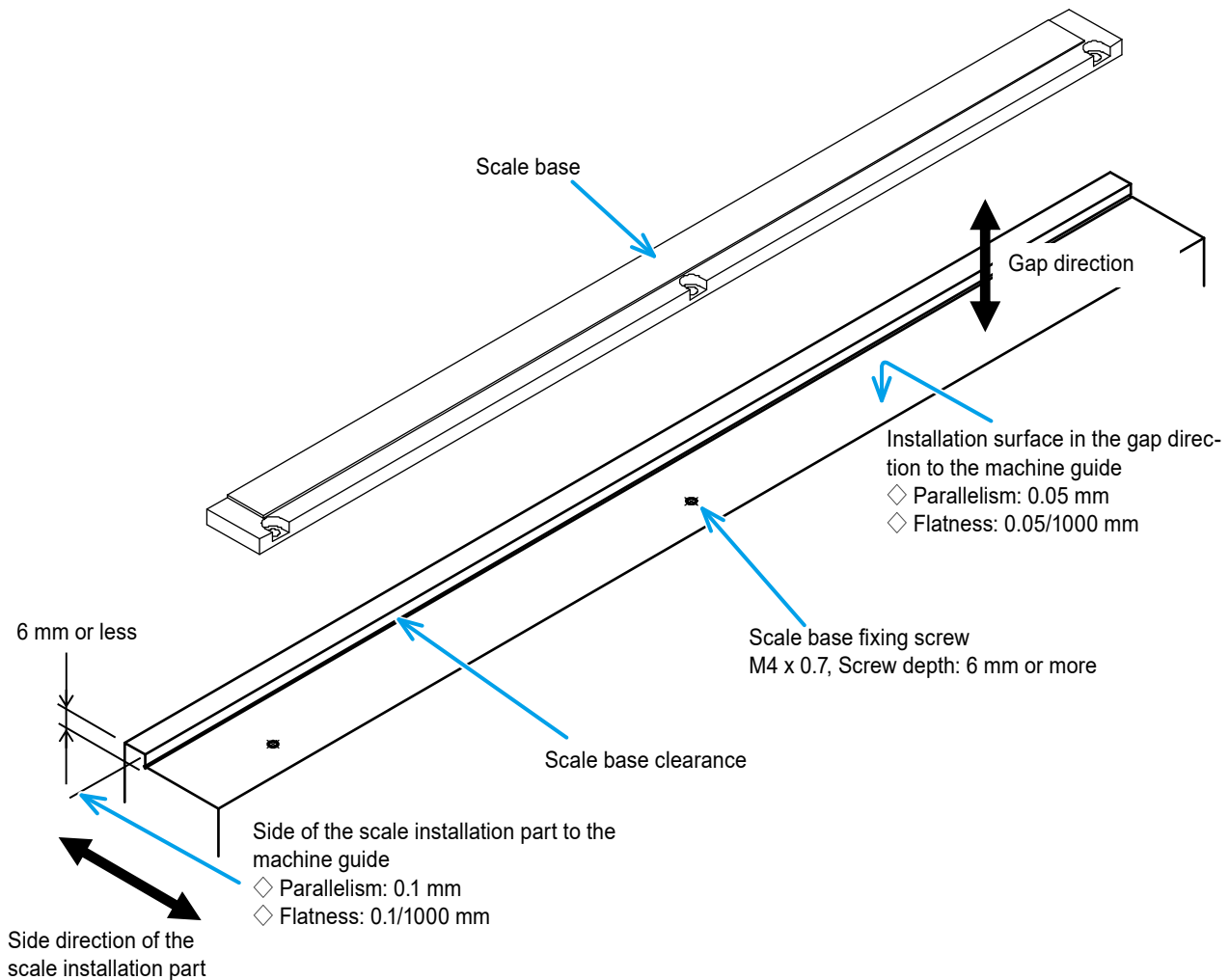

Tips

If you cannot set the side of the scale installation part (shown in the figure above), you can use the positioning reference pin instead. In such a case, set the reference pin according to the installation hole pitch. Even in this case, the above standard values must be secured for the parallelism to the machine guide.

2.3.1 Selecting the Material of the Scale Installation Part

It is recommended to use an iron material similar to the material of the scale base as the material of the scale installation part by considering changes in temperature. If you have no choice but to use an aluminum material, install the unit in an environment with the standard temperature that does not change a lot ($20\text{ }^{\circ}\text{C} \pm 3\text{ }^{\circ}\text{C}$ recommended).

2.4 Designing the Detector Bracket



Design the Detector bracket according to "4.4 Dimensional Drawings". The dimensions must allow positioning adjustment in the side and gap directions of the Detector. It is recommended that the Detector fixing screw hole should be a long hole that makes it easier to adjust in the side or gap direction of the Detector.

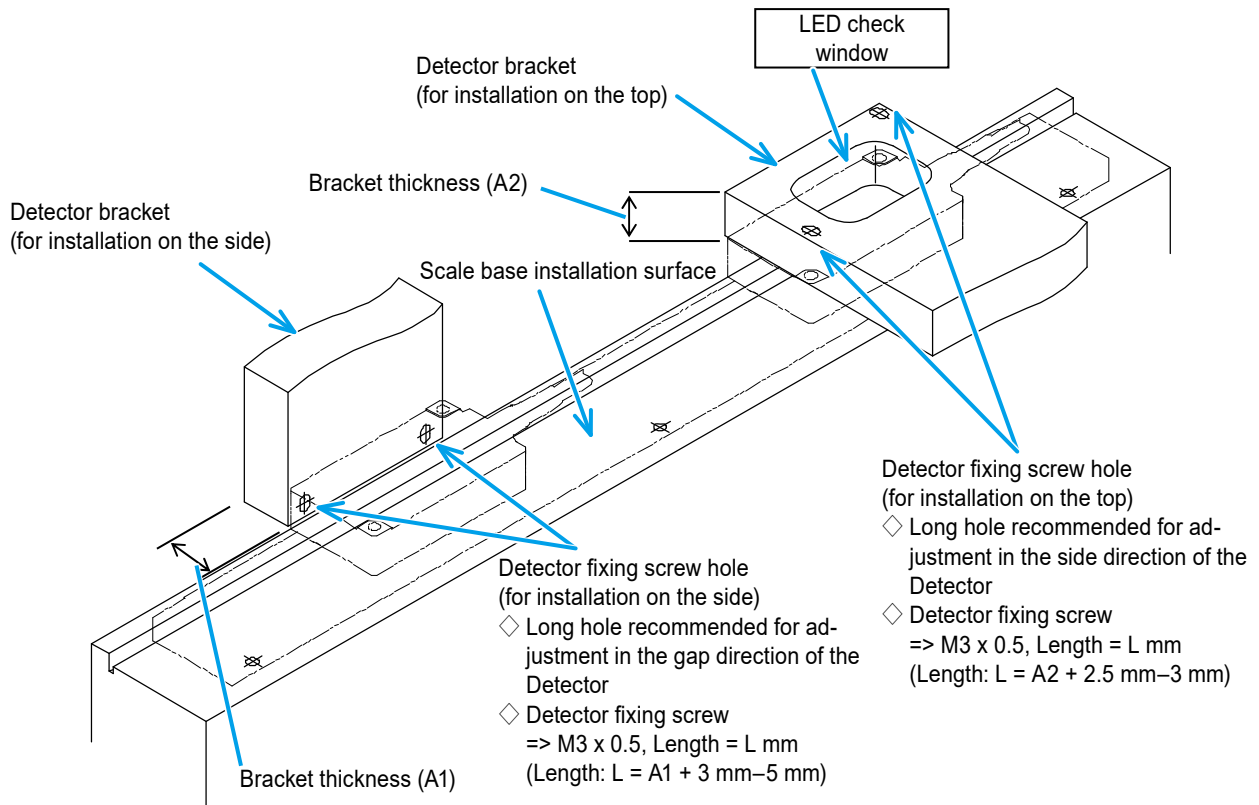

Tips

- Design the Detector bracket so that the scale base can be grounded as GND to frame ground through the installation part material at installation.
- Determine the bracket thickness by taking the Detector installation screw depth (side: 5 mm, top: 3 mm) into account. Please note that insufficient thickness may lower the Detector rigidity, decreasing the servo rigidity, accordingly.

MEMO

3 Installation onto the Machine Main Unit

This chapter describes the procedures, methods, and precautions required when installing this product onto the machine main unit.

3.1 Checking the Package Contents

Before starting installation, make sure that the product package contains all of the following items.

If the specifications of your scale are not as specified or you have any questions, contact your dealer or the nearest Mitutoyo office/service center.

Name	Quantity	Note
Scale base	1	Check the effective measurement length.
Detector	1 *1	Check the model number.
Installation spacer	1	t=0.4 mm
Serial No. tag	1	Make sure that the scale base and the Detector have the same number.
User's Manual	1	This manual
Inspection certificate	1	
Warranty card	1	

*1: For the multi-head specification (custom specification of two or more Detectors), the number of Detectors is different.

3.2 Installing the Scale Base



- Before installing the scale base, clean the scale base installation surface and scale base backside with alcohol.
- Do not remove the protection tape on the scale base surface.

1 Place the scale base along the scale base installation surface and tighten the screws.

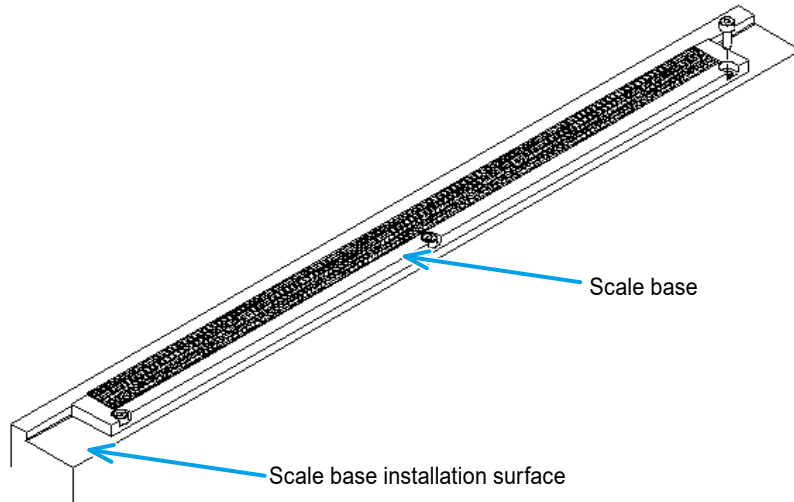

Tips

Screw to use: M4 x 0.7, 6 mm or more

Tightening torque: 3 N•m–4 N•m

3.2.1 Checking after the Scale Base Installation

After installing the scale base, use a lever type dial test indicator to make sure that the parallelism of the scale base side to the machine guide is 0.2 mm or less.

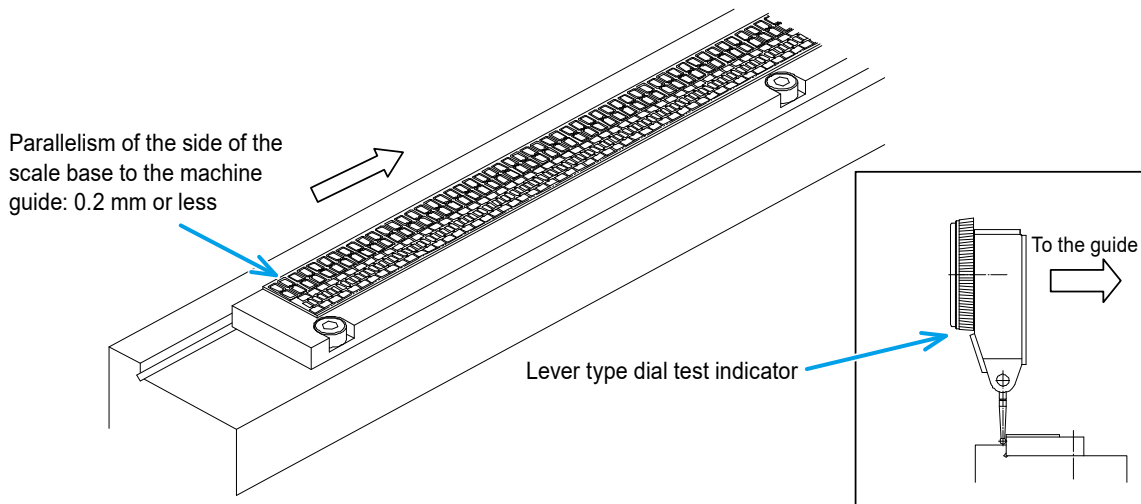

3.3 Installing the Detector Bracket and the Detector

3.3.1 Installing the Detector Bracket

1 Install the Detector bracket.



Install the Detector bracket so that there is a predetermined distance between the bracket and the side of the Detector.

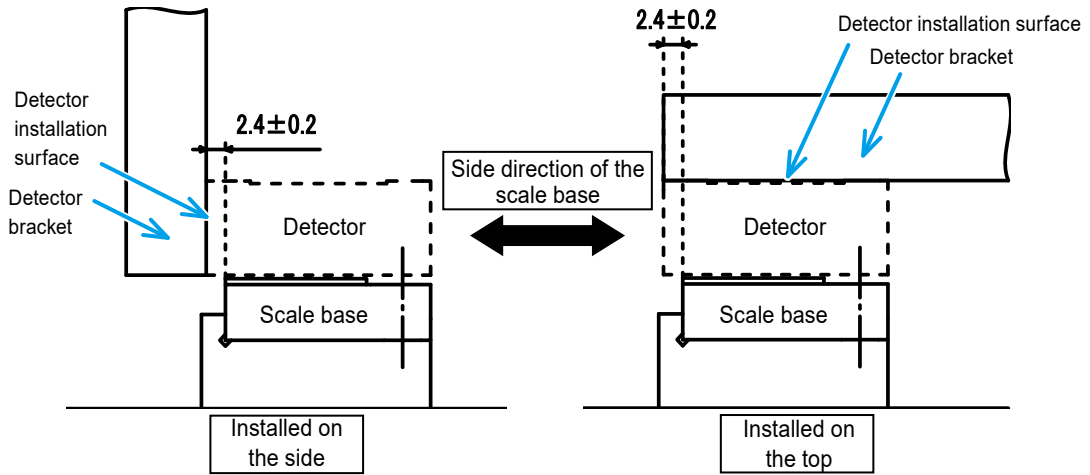

3.3.2 Installing the Detector



The Detector must be installed so that it can be used with the machine main unit, including the bracket to be installed, electrically connected to ground. Without grounding, the unit may be affected by external noise. If it is difficult to ground due to the bracket material, securely connect the shielded part of the Detector cable to ground using a ground bar.

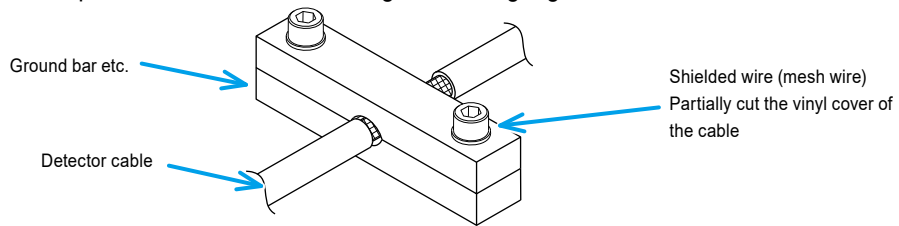

Example: Ground bar usage drawing

3 Installation onto the Machine Main Unit

- 1 Install the Detector on the Detector bracket by loosely tightening the screws (temporary fixing).

Tips

If you do not know the installation direction of the Detector, check it in the figure below.

Orientation of the sticker on the Detector
(placed on the front)

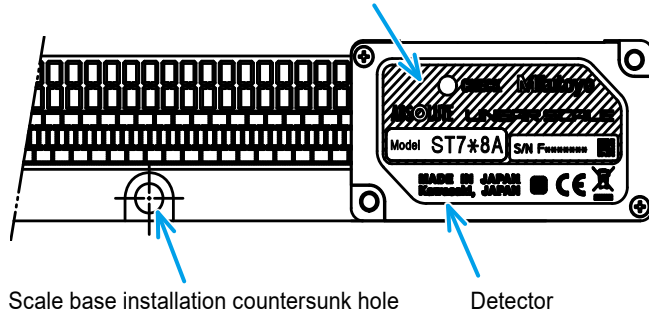

- 2 Insert the supplied installation spacer (t = 0.4 mm) in between the detection surface of the Detector and the pitch surface of the scale base.

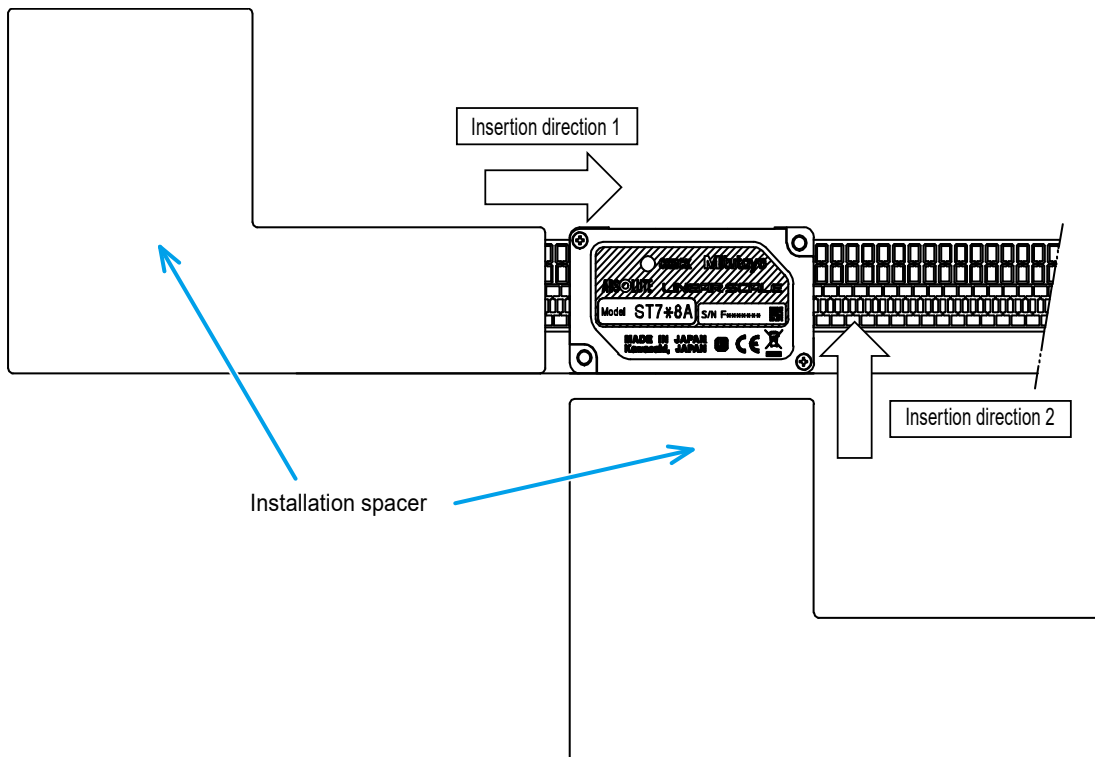

- 3 Fix the Detector by tightening the screws.

NOTICE

During positioning with the installation spacer, if the Detector is fixed, being pushed hard against the scale, the installation spacer may not be pulled out. In such a case, if you try to pull them out forcibly, the pitch surface of the scale base or the detection surface of the Detector may be damaged.

3 Installation onto the Machine Main Unit



- When you install the Detector bracket on the side of the Detector, please note the following:
Screw to use: M3 x 0.5, Length = L mm ($L = A1 + 3 \text{ mm} - 5 \text{ mm}$)
Tightening torque: 3 N•m–3.5 N•m

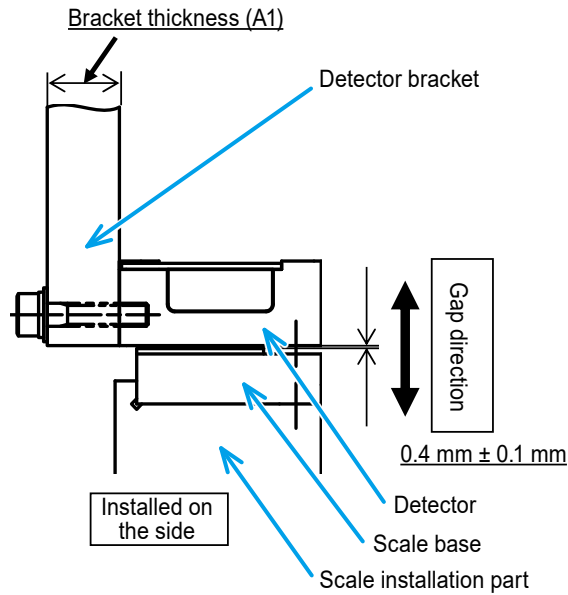

- When you install the Detector bracket on the top of the Detector, please note the following:
Screw to use: M3 x 0.5, Length = L mm ($L = A2 + 2 \text{ mm} - 3 \text{ mm}$)
Tightening torque: 3 N•m–3.5 N•m

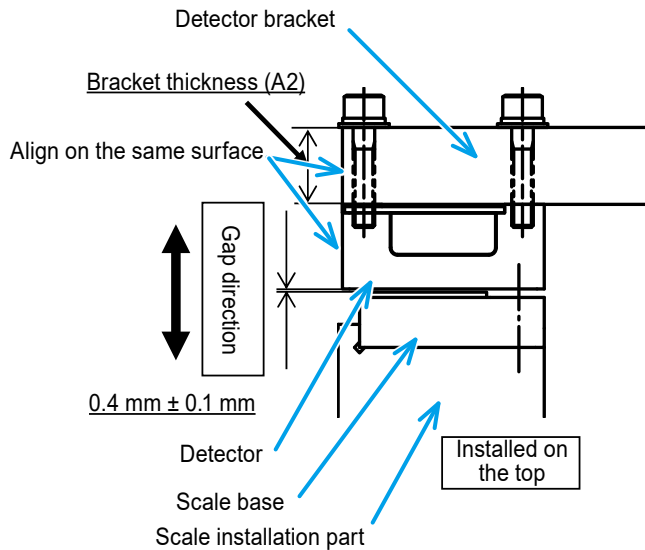

- When you install the Detector bracket on the top of the Detector, it is recommended to adjust the gap using the following procedure:
 - 1 Install the Detector on the Detector bracket.
 - 2 In this state, align the end faces.
 - 3 Adjust the gap including the Detector bracket.

4 Pull out the installation spacer.

3.4 Connecting the Cables

After installing the Detector, connect and fix the cables.



A feedback cable must be prepared by yourself. Find a cable appropriate for your model according to "4.2 Pin Assignment" (page 21).

1 Perform wiring paying attention to the twisting or bends of the cables.



Note that the Detector cable and feedback cable may malfunction if bundled with other cables that may cause electrical noise, or if they are located near a switching relay dealing with a large current.

2 Use cable clamps or other fasteners to secure the cables.

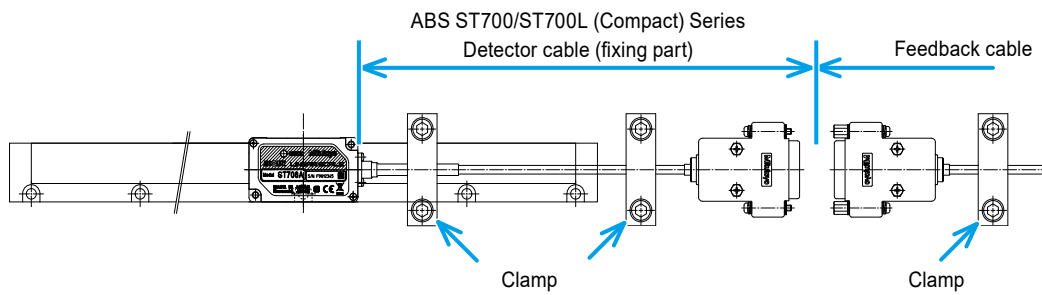

Tips

Note the following:

- Consider the shake due to vibration given to connectors.

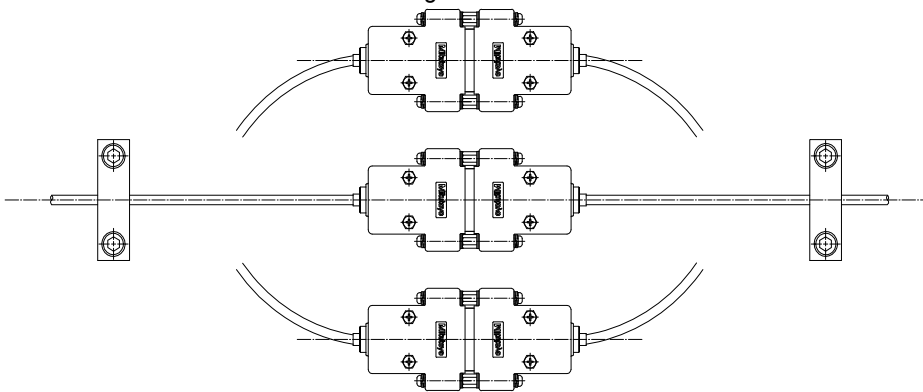

3 Installation onto the Machine Main Unit

- If the cables are going to be repeatedly bent, the feedback cable, not the output cable, should be movable. Please also avoid stress applied to near the root of the clamping part.

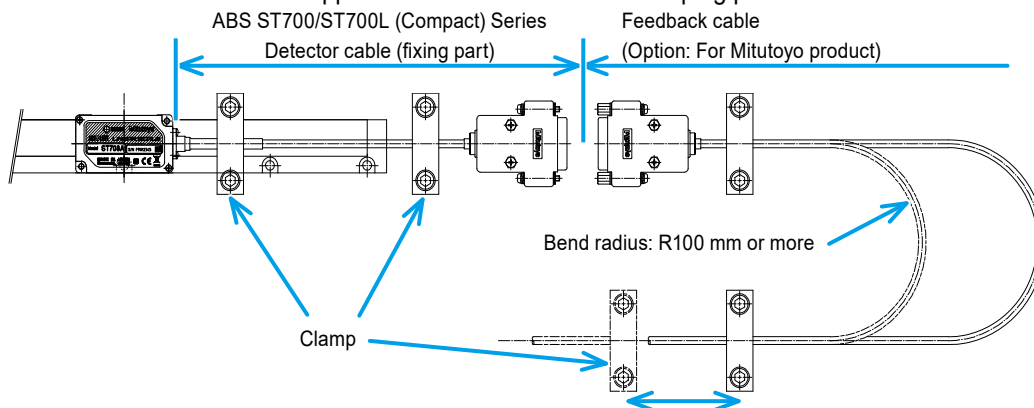

- If the Detector cable needs to be bent, secure the bend radius as shown below:

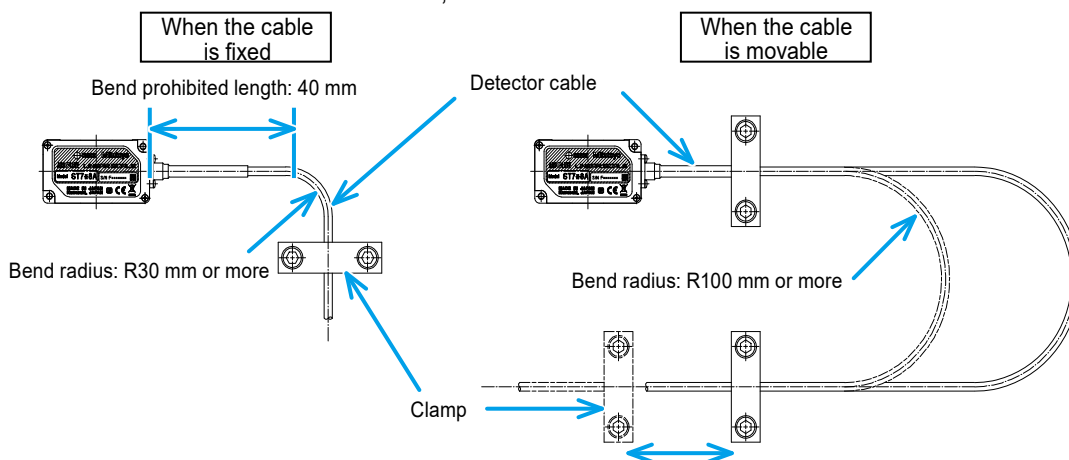

- It is recommended to attach the accessory Serial No. tag to a cable near the servo amplifier input connector so that the serial number of the linear scale can be easily checked.

MEMO

4 Specification

This chapter describes the specifications of this product.

4.1 Specifications

Item	Specification	
Detection method	Electromagnetic induction absolute position detection method	
Scale type	Separate type scale	
Resolution	0.1 μm	
Effective length (accuracy guaranteed range)	ABS ST700 (Compact) Series (effective measurement length: 3 m or less) 100/200/300/400/500/600/700/800/900/1000/1100/1200/ 1300/1400/1500/1600/1700/1800/1900/2000/2100/2200/ 2300/2400/2500/2600/2700/2800/2900/3000 mm ABS ST700L (Compact) Series (effective measurement length: 3.2m–6 m) 3200/3400/3600/3800/4000/4200/4400/4600/4800/5000/ 5200/5400/5600/5800/6000 mm	
Maximum travel length	Effective measurement length +10 mm (Refer to  "4.4 Dimensional Drawings" (page 26).)	
Indication precision (at 20 °C)	5 + (5L ₀ /1000) μm , L ₀ : Effective measurement length (mm)	
Maximum feedrate	5 m/s	
Maximum feed acceleration	50 m/s ²	
Coefficient of linear expansion	(12.0 \pm 1.5) $\times 10^{-6}/^{\circ}\text{C}$ (when the material of the installation part is equivalent to iron)	
Usage condition	<u>(Effective measurement length: 3m or less)</u> Temperature: 0 °C–50 °C Humidity: 20 %–80 % RH (non condensation)	<u>(Effective measurement length: 3.2–6m)</u> Temperature: 0 °C–50 °C Humidity: 20 %–70 % RH (non condensation)
Storage condition	<u>(Effective measurement length: 3m or less)</u> Temperature: -20 °C–70 °C Humidity: 20 %–80 % RH (non condensation)	<u>(Effective measurement length: 3.2–6m)</u> Temperature: -20 °C–60 °C Humidity: 20 %–70 % RH (non condensation)
Power supply voltage	5 V \pm 10 % (ripple and spike noise components must be 100 mV or less)	
Maximum current consumption	270 mA	
Vibration resistance (55 Hz–2000 Hz)	300 m/s ²	
Shock resistance (1/2 sin, 11 ms)	500 m/s ²	

4 Specification

Interface	Mitutoyo ENSIS® high-speed serial interface
	Mitsubishi Electric Corporation Specifications MELSERVO high-speed serial interface
	Mitsubishi Electric Corporation Specifications CNC Series high-speed serial interface
	Panasonic Corporation MINAS high-speed serial interface
	Yaskawa Electric Corporation Specifications Σ Series high-speed serial interface
	FANUC Corporation Specifications high-speed serial interface
Detector cable	Length/Diameter: 1 m/ ϕ 3.8 mm
Maximum cable length	29 m (including Detector cable)
EMC standard	Compliant with CE marking

4 Specification

4.2.2 ABS ST748A, ST748AL Mitsubishi Electric Corporation Specifications MELSERVO MR-J2

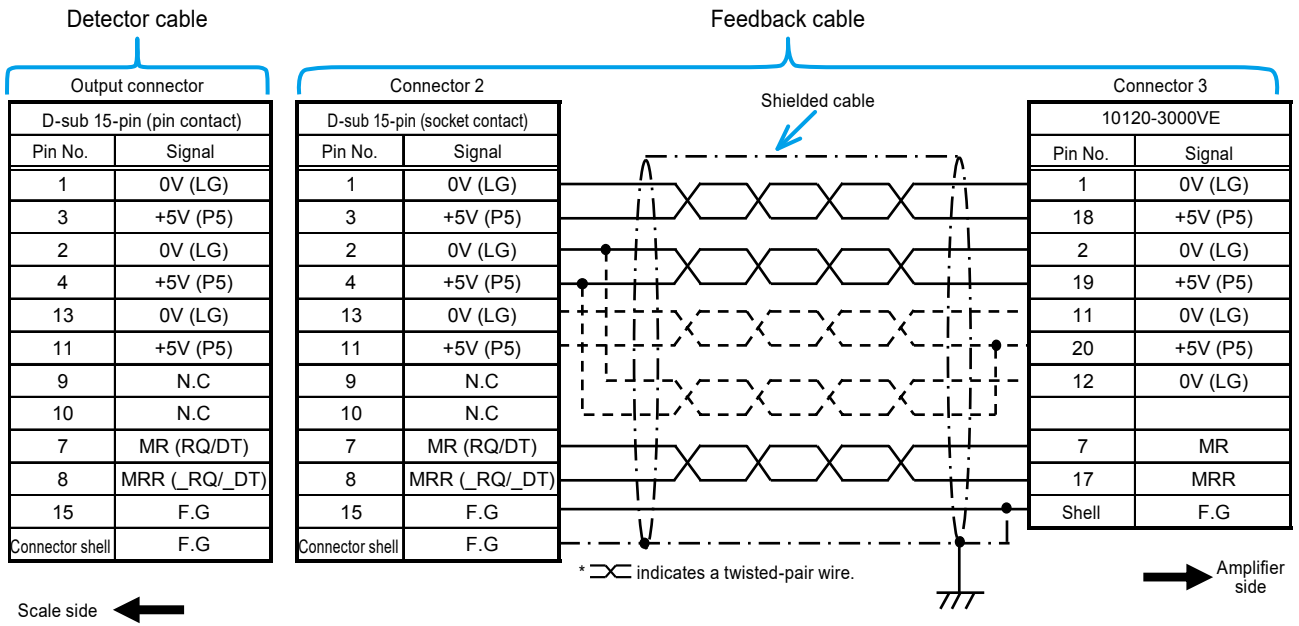

4.2.3 ABS ST748A, ST748AL Mitsubishi Electric Corporation Specifications MELSERVO MR-J3/MR-J4

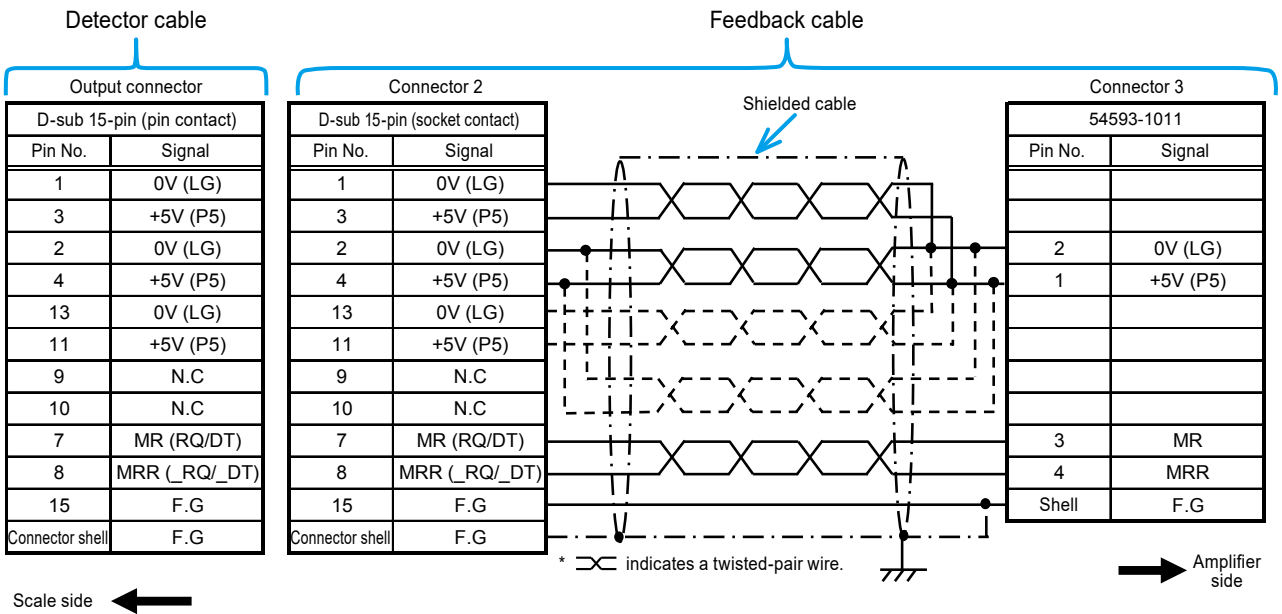

4.2.4 ABS ST748, ST748L Mitsubishi Electric Corporation Specifications CNC Series DS-D, MDS-DH, MDS-Dn

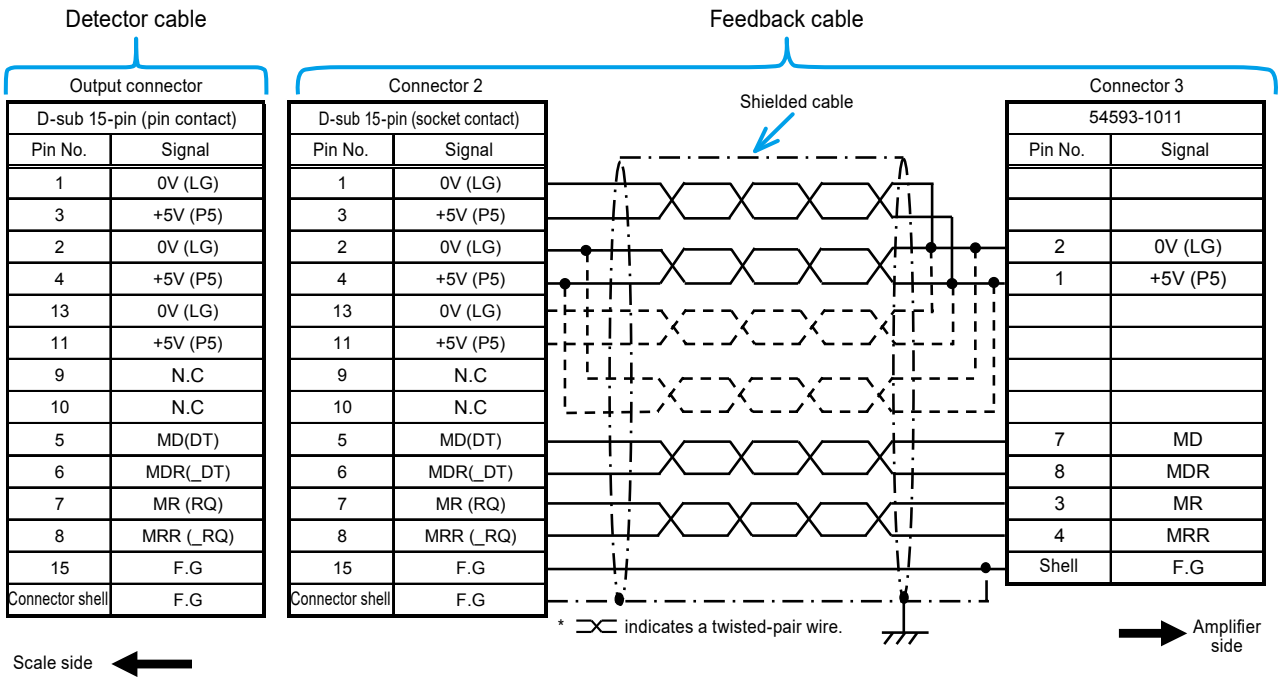

4.2.5 ABS ST758, ST758L FANUC Corporation

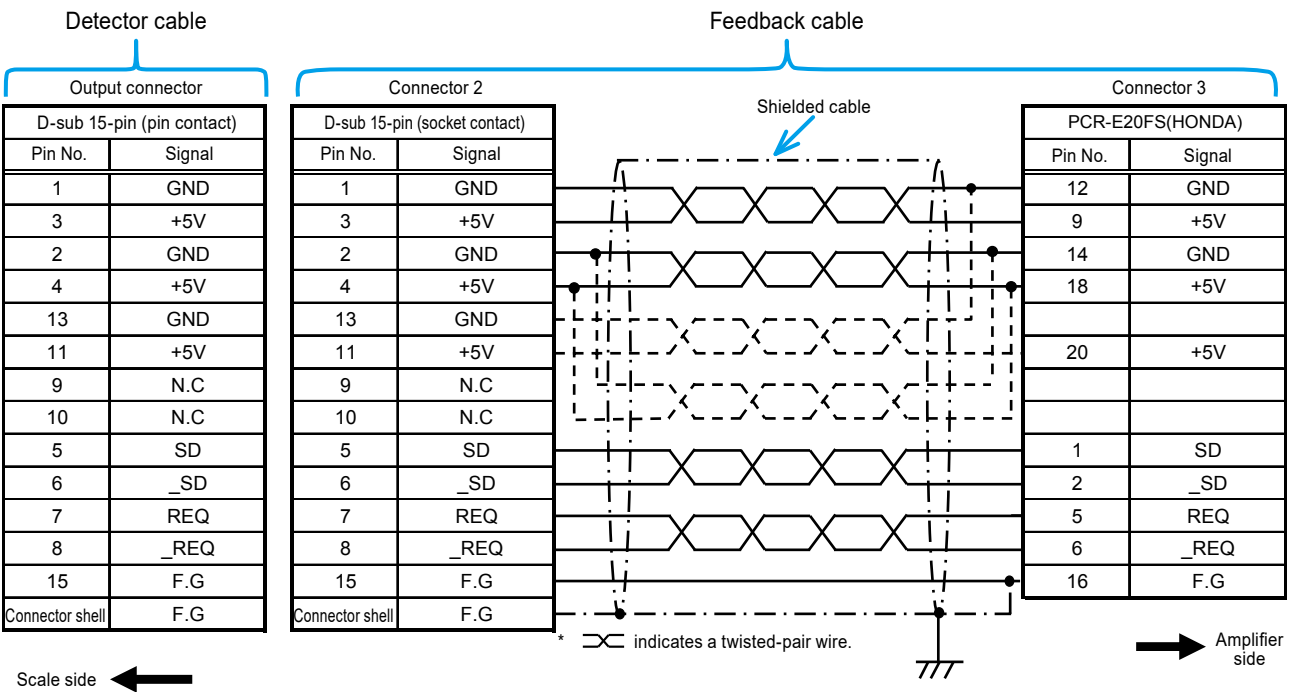

4.2.6 ABS ST778A, ST778AL Panasonic Corporation

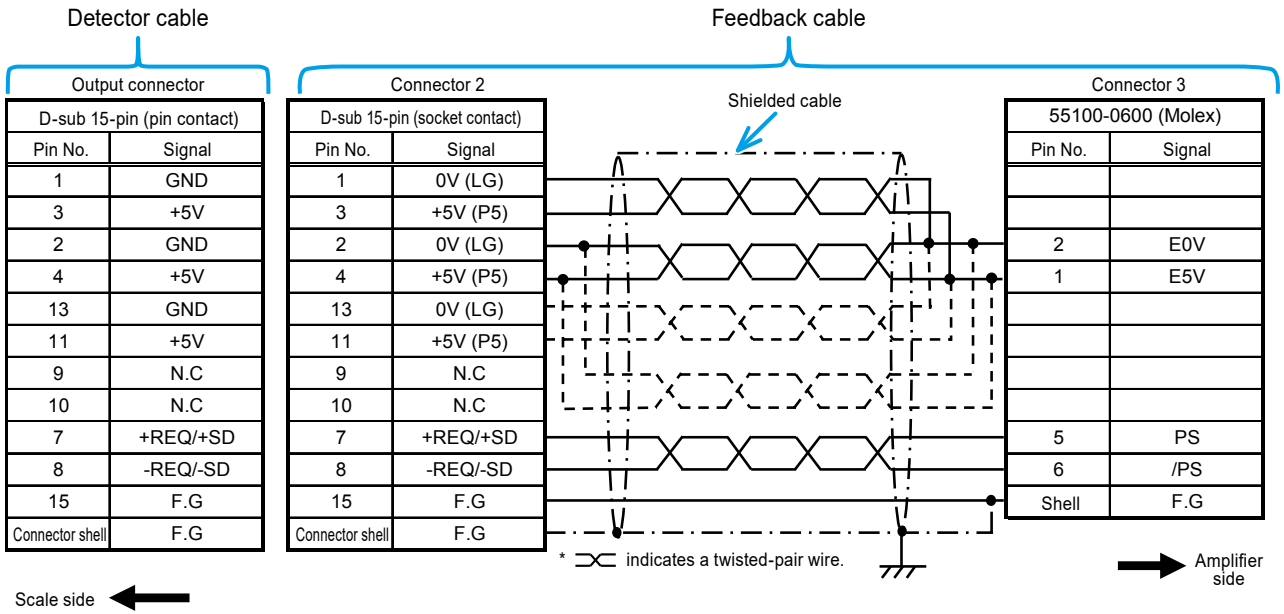

4.2.7 ABS ST788A, ST788AL Yaskawa Electric Corporation

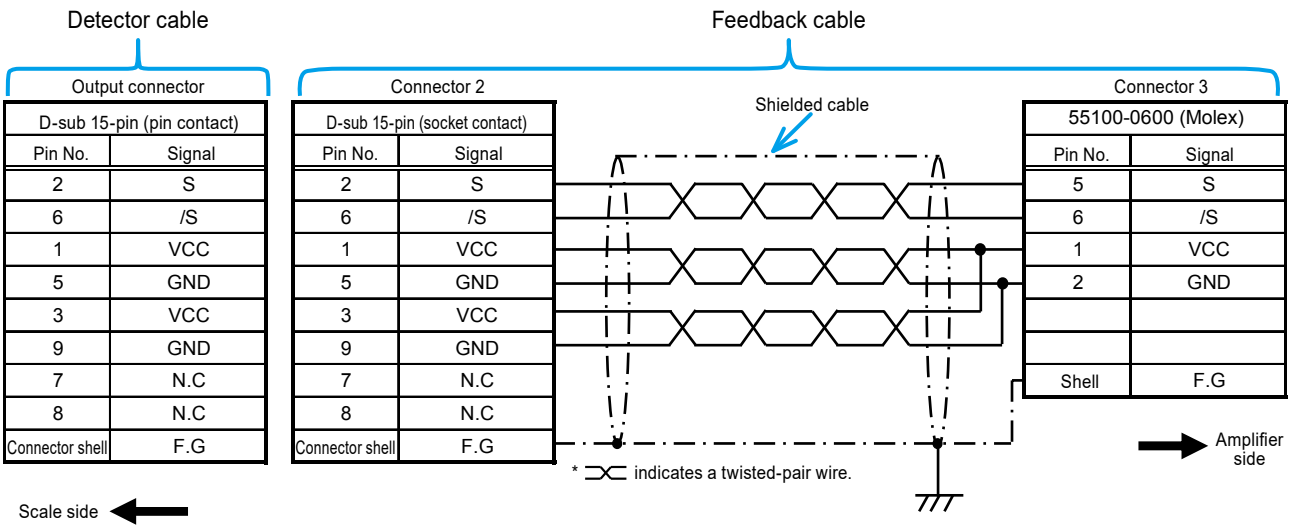

4.3 Calculation of Feedback Cable Length

When making a feedback cable, refer to the following calculation method of maximum cable length.

■ Configuration

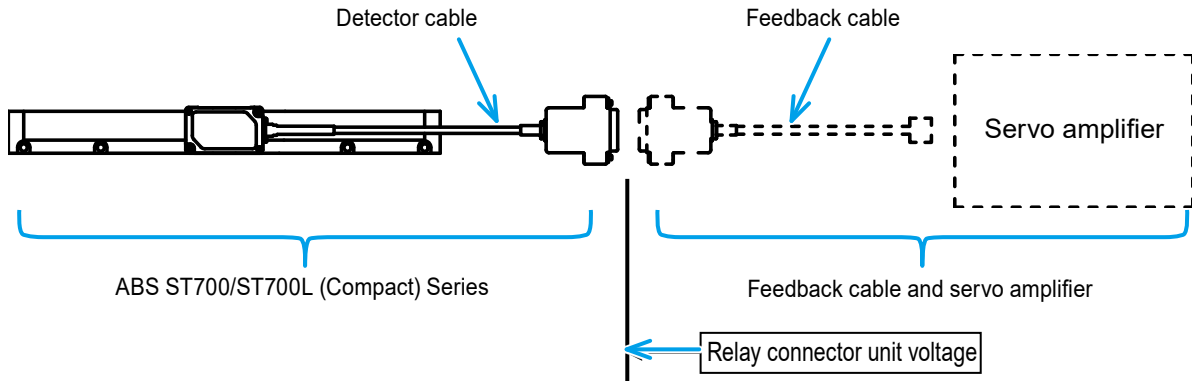

■ Condition: When the Detector cable length is 1 m

Name	Specifications and symbols	Unit
Maximum cable length	L	m
Wire resistance of used wire material	a	Ω/m
Number of pairs used for power supply line	b	wires
Supply voltage (minimum value) from the servo amplifier	4.95 *1	V
Current consumption value	0.27	A
Relay connector unit voltage (minimum value)	4.57 *2	V

*1 This is standard supply voltage on the servo amplifier.

*2 When the Detector cable length is longer than the default 1 m, a voltage drop of 0.07 V per 1 m occurs. Consider the voltage drop in the Detector cable.

■ Calculation formula

Allowable voltage drop \geq (Current consumption x wire material resistance x 2 x max cable length) ÷ Number of pairs used for power supply line (1)

Applying the conditions in the above table to formula (1) gives the following result.

$$(4.95 - 4.57) [V] \geq (0.27 [A] \times a [\Omega/m] \times 2 \times L [m]) \div b [wires] \quad (2)$$

Modify formula (2) above to the following one.

$$L [m] \leq \frac{b (4.95 - 4.57)}{0.54 a} \quad (3)$$

Produce the feedback cable of the max cable length (L[m]), wire resistance of used wire material (a[Ω/m]) and number of pairs used for power supply line (b[wires]) satisfying formula (3) above.

4.4 Dimensional Drawings

4.4.1 ABS ST700 (Compact) Series

■ Dimensional drawing

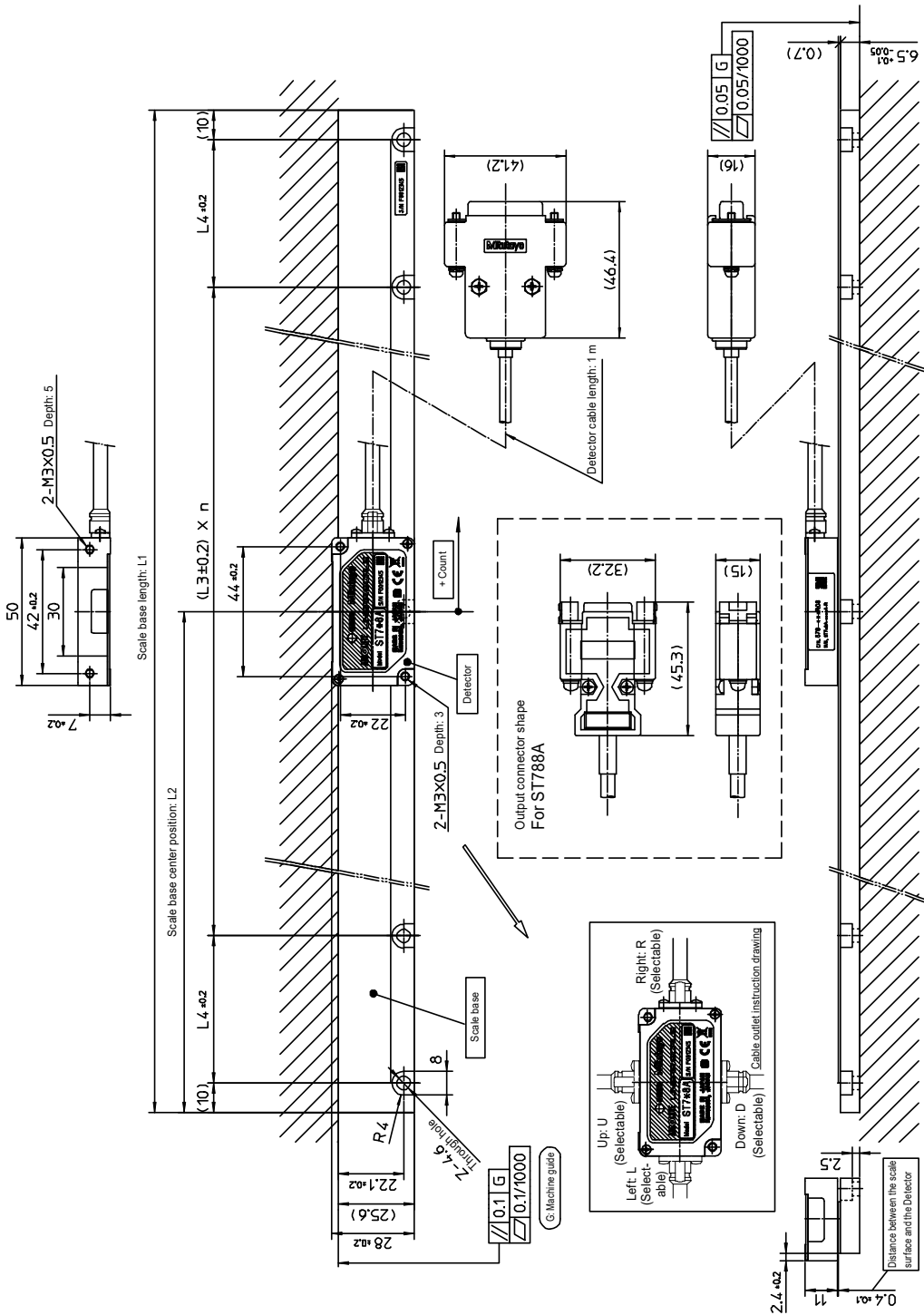

Dimension table

Dimension table (common to ABS ST700 (Compact) Series: effective measurement length of 3 m or less)

Code No. (*1, *2)	Model number (*1, *3)	Effective measure- ment length (mm)	Maxi- mum travel length (mm)	L1 (mm)	L2 (mm)	L3 (mm)	n	L4 (mm)	Z
579-301*□8	ABS ST7◇8(A)-100A-*	100	110	180	90	80	2		3
579-302*□8	ABS ST7◇8(A)-200A-*	200	210	280	140	130			
579-303*□8	ABS ST7◇8(A)-300A-*	300	310	380	190	180			
579-304*□8	ABS ST7◇8(A)-400A-*	400	410	480	240	230			
579-305*□8	ABS ST7◇8(A)-500A-*	500	510	580	290	200	2	80	5
579-306*□8	ABS ST7◇8(A)-600A-*	600	610	680	340			130	
579-307*□8	ABS ST7◇8(A)-700A-*	700	710	780	390			180	
579-308*□8	ABS ST7◇8(A)-800A-*	800	810	880	440			230	
579-309*□8	ABS ST7◇8(A)-900A-*	900	910	980	490	200	4	80	7
579-310*□8	ABS ST7◇8(A)-1000A-*	1000	1010	1080	540			130	
579-311*□8	ABS ST7◇8(A)-1100A-*	1100	1110	1180	590			180	
579-312*□8	ABS ST7◇8(A)-1200A-*	1200	1210	1280	640			230	
579-313*□8	ABS ST7◇8(A)-1300A-*	1300	1310	1380	690	200	6	80	9
579-314*□8	ABS ST7◇8(A)-1400A-*	1400	1410	1480	740			130	
579-315*□8	ABS ST7◇8(A)-1500A-*	1500	1510	1580	790			180	
579-316*□8	ABS ST7◇8(A)-1600A-*	1600	1610	1680	840			230	
579-317*□8	ABS ST7◇8(A)-1700A-*	1700	1710	1780	890	200	8	80	11
579-318*□8	ABS ST7◇8(A)-1800A-*	1800	1810	1880	940			130	
579-319*□8	ABS ST7◇8(A)-1900A-*	1900	1910	1980	990			180	
579-320*□8	ABS ST7◇8(A)-2000A-*	2000	2010	2080	1040			230	
579-321*□8	ABS ST7◇8(A)-2100A-*	2100	2110	2180	1090	200	10	80	13
579-322*□8	ABS ST7◇8(A)-2200A-*	2200	2210	2280	1140			130	
579-323*□8	ABS ST7◇8(A)-2300A-*	2300	2310	2380	1190			180	
579-324*□8	ABS ST7◇8(A)-2400A-*	2400	2410	2480	1240			230	
579-325*□8	ABS ST7◇8(A)-2500A-*	2500	2510	2580	1290	200	12	80	15
579-326*□8	ABS ST7◇8(A)-2600A-*	2600	2610	2680	1340			130	
579-327*□8	ABS ST7◇8(A)-2700A-*	2700	2710	2780	1390			180	
579-328*□8	ABS ST7◇8(A)-2800A-*	2800	2810	2880	1440			230	
579-329*□8	ABS ST7◇8(A)-2900A-*	2900	2910	2980	1490	200	14	80	17
579-330*□8	ABS ST7◇8(A)-3000A-*	3000	3010	3080	1540			130	

*1: * (asterisk) in the code No. and model number indicates the Detector cable outlet direction.
R: Right (Standard), D: Down (Selectable), L: Left (Selectable), U: Up (Selectable)

*2: □ in the code No. indicates the following:

- 0: Mitutoyo Corporation ENSIS®
- 3: Mitsubishi Electric Corporation CNC Series
- 4: Mitsubishi Electric Corporation MELSERVO
- 5: FANUC Corporation
- 7: Panasonic Corporation
- 8: Yaskawa Electric Corporation

*3: ◇ in the model number indicates the interface specifications: For details, refer to  "2.1 Checking the Equipment Model" (page 5).

4.4.2 ABS ST700L (Compact) Series

Dimensional drawing

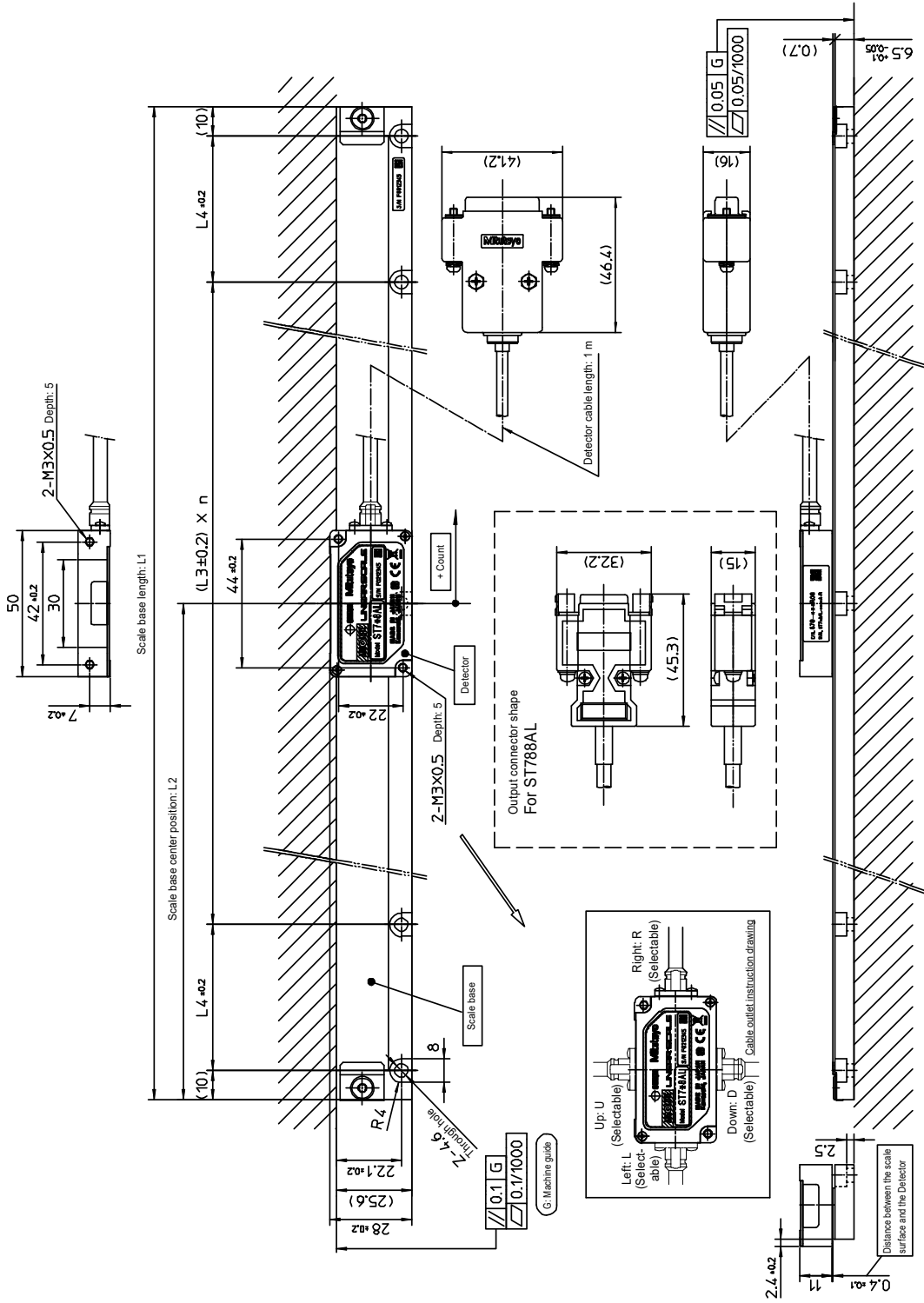

■ Dimension table

Dimension table (common to ABS ST700L (Compact) Series: effective measurement length of 3.2 m–6 m)

Code No. (*1, *2)	Model number (*1, *3)	Effective measurement length (mm)	Maximum travel length (mm)	L1 (mm)	L2 (mm)	L3 (mm)	n	L4 (mm)	Z
579-331*□8	ABS ST7◇8(A)L-3200A-*	3200	3210	3280	1640	200	14	230	17
579-332*□8	ABS ST7◇8(A)L-3400A-*	3400	3410	3480	1740		16	130	19
579-333*□8	ABS ST7◇8(A)L-3600A-*	3600	3610	3680	1840			230	
579-334*□8	ABS ST7◇8(A)L-3800A-*	3800	3810	3880	1940		18	130	21
579-335*□8	ABS ST7◇8(A)L-4000A-*	4000	4010	4080	2040			230	
579-336*□8	ABS ST7◇8(A)L-4200A-*	4200	4210	4280	2140		20	130	23
579-337*□8	ABS ST7◇8(A)L-4400A-*	4400	4410	4480	2240			230	
579-338*□8	ABS ST7◇8(A)L-4600A-*	4600	4610	4680	2340		22	130	25
579-339*□8	ABS ST7◇8(A)L-4800A-*	4800	4810	4880	2440			230	
579-340*□8	ABS ST7◇8(A)L-5000A-*	5000	5010	5080	2540		24	130	27
579-341*□8	ABS ST7◇8(A)L-5200A-*	5200	5210	5280	2640			230	
579-342*□8	ABS ST7◇8(A)L-5400A-*	5400	5410	5480	2740		26	130	29
579-343*□8	ABS ST7◇8(A)L-5600A-*	5600	5610	5680	2840			230	
579-344*□8	ABS ST7◇8(A)L-5800A-*	5800	5810	5880	2940		28	130	31
579-345*□8	ABS ST7◇8(A)L-6000A-*	6000	6010	6080	3040			230	

*1: * (asterisk) in the code No. and model number indicates the Detector cable outlet direction.
R: Right (Standard), D: Down (Selectable), L: Left (Selectable), U: Up (Selectable)

*2: □ in the code No. indicates the following:

- 0: Mitutoyo Corporation ENSIS®
- 3: Mitsubishi Electric Corporation CNC Series
- 4: Mitsubishi Electric Corporation MELSERVO
- 5: FANUC Corporation
- 7: Panasonic Corporation
- 8: Yaskawa Electric Corporation

*3: ◇ in the model number indicates the interface specifications: For details, refer to  "2.1 Checking the Equipment Model" (page 5).

MEMO

5 Troubleshooting

This chapter describes the Alarm Detection function inside the Detector and the alarm codes for each company interface.

5.1 Alarm Function

The ABS ST700/ST700L (Compact) Series is equipped with the Alarm Detection function inside the Detector.

5.1.1 Alarm Detections

Alarms detected with the Alarm Detection function can be categorized into the following two groups: Caution and Error.

- **Caution:** Indicates low-level signal strength or the temperature error inside the Detector, detected by the sensor. In those cases, once troubleshoot the causes, the normal state can be restored.
- **Error:** Indicates a signal strength error or absolute value detection error, etc., detected by the sensor. Once these errors occur, the error detection state will be maintained until they are reset, or the power is re-supplied.

Alarm detection type		Description
Caution	Temperature error	This alarm is output when the temperature inside the Detector rises above 65 °C and returns to the normal state when it drops below 60 °C.
	Signal strength	This alarm is output when the signal strength drops below 30 % and returns to the normal state when it rises above 30 %.
Error	Signal strength	This alarm is output when the signal strength drops below 15 % or reaches 100 %.
	Transducer	This alarm is output when an abnormality is found in the internal signal balance.
	Absolute value detection	This alarm is output when an abnormality is found in the absolute value data.
	Hardware	This alarm is output when an abnormality is found in the internal hardware.
	Initialization	This alarm is output when system initialization is not successfully completed at power-on.
	Overspeed	This alarm is output when the maximum feedrate (5 m/s) is exceeded.

The intensity of the signal strength is expressed based on the three regions as shown in the figure below. The LED shows the intensity so that you can easily check the signal strength. The intensity of the signal strength must be within the normal region. If it is in the caution or error region, an alarm is output.

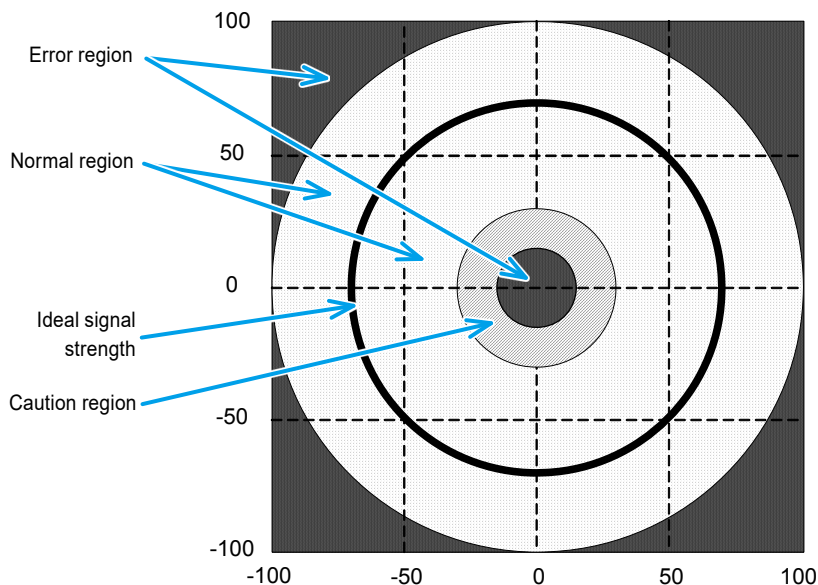

5.1.2 LED Display on the Detector

When an alarm occurs, the LED on the Detector lights up (or flashes). You can tell the details of the alarm by the LED display as shown below.

LED status	Alarm type			Description
	Caution	Error	OK	
Solid red -> OFF	-	-	✓	Power-on LED The LED lights up for about two seconds at power-on, indicating that the power is turned on.
Solid red	✓	✓	-	When both a caution and an error occur, the LED lights up in red. Then, once the cause of the caution is removed, the color turns yellow.
Solid yellow	-	✓	-	When an error occurs, the LED lights up in yellow. This status is maintained until a command is issued from the servo amplifier or the Detector is turned off.
Flashing yellow	✓	-	-	When a caution occurs, the LED flashes in yellow. Once the cause of the caution is removed, the LED is turned off.

Tips

When an alarm occurs during operation, check the details in "5.2 Alarm Codes" and contact the servo amplifier manufacturer or the nearest Mitutoyo sales office/service center.

5.2 Alarm Codes

5.2.1 ABS ST748A, ST748AL

The table below shows the relationship between the ABS ST748A/ST748AL alarm and the alarm code displayed on the servo amplifier made by Mitsubishi Electric Corporation.

Servo amplifier Alarm code	LED status	Description	Cause	Major solution
AL2A	Solid red/solid yellow	Scale error occurred <ul style="list-style-type: none"> • Signal strength error • Transducer error • ABS detection error • Hardware error • Initialization error • Overspeed 	The Detector detected an error.	<ul style="list-style-type: none"> • Use Signal Monitor of the Signal Adjustment Program to check the positional relationship between the Detector and the scale. • Use Calibration Start of the Signal Adjustment Program to perform signal adjustment as necessary.
AL28	Flashing yellow	Scale alarm occurred <ul style="list-style-type: none"> • Thermal alarm • Signal strength alarm 	The Detector detected a caution. The position data is correct; however, it is necessary to check the fixing state and the operating condition.	<ul style="list-style-type: none"> • The surrounding temperature of the Detector may be above 60 °C. If so, review the operation conditions (speed, acceleration). • Use Signal Monitor of the Signal Adjustment Program to check the positional relationship between the Detector and the scale. • Use Calibration Start of the Signal Adjustment Program to perform signal adjustment as necessary.

Servo amplifier Alarm code	LED status	Description	Cause	Major solution
AL16	-	Communication error occurred (during servo amplifier initialization) <ul style="list-style-type: none"> An error was received consecutively three times on the servo amplifier side (including no response). 	A communication error between the ABS ST748A/ST748AL and the servo amplifier occurred (communication impossible from the time of turning on the servo amplifier).	<ul style="list-style-type: none"> Check the connections of cables and connectors. Check the routing of the cable (influence of noise such as large current cable). At power-on, check the LED on the ABS ST748A/ST748AL to see if the power is supplied.
AL20	-	Communication error occurred (during servo amplifier control) <ul style="list-style-type: none"> An error was received consecutively three times on the servo amplifier side (including no response). 	A communication error between the ABS ST748A/ST748AL and the servo amplifier occurred (occurred while controlling by the servo amplifier).	<ul style="list-style-type: none"> Check the connections of cables and connectors. Check the routing of the cable (influence of noise such as large current cable).

5.2.2 ABS ST758, ST758L

The table below shows the relationship between the ABS ST758/ST758L alarm and the alarm code displayed on the servo amplifier made by FANUC Corporation.

Note that the alarm codes of NC devices differ between when using the scale with fully closed control and when using with a linear motor.

Servo amplifier Alarm code	LED status	Description	Cause	Major solution
380 (during fully closed connection) LED error	Solid red/solid yellow	Scale error occurred <ul style="list-style-type: none"> Hardware error 	The Detector detected an error.	Turn on the power again. If an error is found again, the Detector needs to be replaced.
365 (during linear motor) LED error				

5 Troubleshooting

Servo amplifier Alarm code	LED status	Description	Cause	Major solution
381 (during fully closed connection) Phase error 361 (during linear motor) Phase error	Solid red/solid yellow	Scale error occurred <ul style="list-style-type: none"> Initialization error Absolute error Transducer error Overspeed Signal strength error Signal strength warning 	The Detector detected an error.	<ul style="list-style-type: none"> Use Signal Monitor of the Signal Adjustment Program to check the positional relationship between the Detector and the scale. Use Calibration Start of the Signal Adjustment Program to perform signal adjustment as necessary.
385 (during fully closed connection) Serial data error 368 (during linear motor) Serial data error	-	Communication error occurred <ul style="list-style-type: none"> No response 	An error occurred in which data from the scale could not be received due to communication between the ABS ST758/ST758L and the NC device (no response).	<ul style="list-style-type: none"> Check the connections of cables and connectors. Check the routing of the cable (influence of noise such as large current cable).
386 (during fully closed connection) Data transfer error 369 (during linear motor) Data transfer error	-	Communication error occurred <ul style="list-style-type: none"> Communication error 	A CRC error and a stop bit error occurred in the serial data from the scale in communication between the ABS ST758/ST758L and the NC device (communication error).	Check the routing of the cable (influence of noise such as large current cable).
447 (during fully closed connection) Hardware disconnection alarm 446 (during linear motor) Hardware disconnection alarm	-	Communication error occurred <ul style="list-style-type: none"> Cable disconnection 	An error caused by cable disconnection occurred in communication between the ABS ST758/ST758L and the NC device.	Check the connections of cables and connectors.

5.2.3 ABS ST778A, ST778AL

The table below shows the relationship between the ABS ST778A/ST778AL alarm and the alarm code displayed on the servo amplifier (MINAS A6 Series) made by Panasonic Corporation.

Tips

The alarm codes in this section indicate ones that occur on a servo amplifier that is a fully closed system.

Servo amplifier Alarm code	LED status	Description	Cause	Major solution
Err51.0	Solid yellow	Scale error occurred • Overspeed	The Detector detected an overspeed error.	<ul style="list-style-type: none"> Review the operation condition (specified speed).
Err51.1	Solid red/solid yellow	Scale error occurred • Initialization error	The Detector detected an error during initialization.	<ul style="list-style-type: none"> Use Signal Monitor of the Signal Adjustment Program to check the positional relationship between the Detector and the scale. Use Calibration Start of the Signal Adjustment Program to perform signal adjustment as necessary.
Err51.2	Solid red/solid yellow	Scale error occurred • Hardware error	The Detector detected an error.	Turn on the power again. If an error is found again, the Detector needs to be replaced.
Err51.3	Solid red/solid yellow	Scale error occurred • Absolute error	The Detector detected an error.	<ul style="list-style-type: none"> Use Signal Monitor of the Signal Adjustment Program to check the positional relationship between the Detector and the scale. Use Calibration Start of the Signal Adjustment Program to perform signal adjustment as necessary.

5 Troubleshooting

Servo amplifier Alarm code	LED status	Description	Cause	Major solution
Err51.4	Solid red/solid yellow	Scale error occurred <ul style="list-style-type: none"> • Transducer error 	The Detector detected an error.	<ul style="list-style-type: none"> • Use Signal Monitor of the Signal Adjustment Program to check the positional relationship between the Detector and the scale. • Use Calibration Start of the Signal Adjustment Program to perform signal adjustment as necessary.
Err51.5	Flashing yellow	Scale alarm occurred <ul style="list-style-type: none"> • Signal strength error 	The Detector detected a caution. The position data is correct; however, it is necessary to check the fixing state and the operating condition.	<ul style="list-style-type: none"> • Use Signal Monitor of the Signal Adjustment Program to check the positional relationship between the Detector and the scale. • Use Calibration Start of the Signal Adjustment Program to perform signal adjustment as necessary.
Err50.0 Err50.1	-	Communication error occurred	A communication error between the ABS ST778A/ST778AL and the servo amplifier occurred.	<ul style="list-style-type: none"> • Check the connections of cables and connectors. • Check the routing of the cable (influence of noise such as large current cable).

5.2.4 ABS ST788A, ST788AL

The table below shows the relationship between the ABS ST788A/ST788AL alarm and the alarm code displayed on the servo amplifier (Σ Series) made by Yaskawa Electric Corporation.

Note that the alarm codes of NC devices differ between when using the scale with fully closed control and when using with a linear motor.

Servo amplifier Alarm code	LED status	Description	Cause	Major solution
A.8A3 ^{*1} A.84U ^{*2}	Solid red/solid yellow	Scale error occurred <ul style="list-style-type: none"> • Signal strength error • Transducer error • Absolute value detection error • Initialization error 	The Detector detected an error.	<ul style="list-style-type: none"> • Use Signal Monitor of the Signal Adjustment Program to check the positional relationship between the Detector and the scale. • Use Calibration Start of the Signal Adjustment Program to perform signal adjustment as necessary.
A.8A5 ^{*1} A.85U ^{*2}	Solid yellow	Scale error occurred <ul style="list-style-type: none"> • Overspeed 	The Detector detected an overspeed error.	Review the operation condition (specified speed).
A.8A6 ^{*1} A.860 ^{*2}	Flashing yellow	Scale alarm occurred <ul style="list-style-type: none"> • Thermal alarm • Signal strength alarm 	The Detector detected a caution. The position data is correct; however, it is necessary to check the fixing state and the operating condition.	<ul style="list-style-type: none"> • The surrounding temperature of the Detector may be above 60 °C. If so, review the operation conditions (speed, acceleration). • Use Signal Monitor of the Signal Adjustment Program to check the positional relationship between the Detector and the scale. • Use Calibration Start of the Signal Adjustment Program to perform signal adjustment as necessary.

*1 When using the scale with fully closed control

*2 When using the scale with a linear motor

5 Troubleshooting

Servo amplifier Alarm code	LED status	Description	Cause	Major solution
A.8A1 *1 A.891 *2	Solid red/solid yellow	Scale error occurred • Hardware error	The Detector detected an error.	The Detector needs to be replaced.
A.CF1 *1 C90 *2	-	Communication error occurred (during servo amplifier control)	A communication error between the ABS ST788A/ST788AL and the servo amplifier occurred (occurred while controlling by the servo amplifier).	<ul style="list-style-type: none"> • Check the connections of cables and connectors. • Check the routing of the cable (influence of noise such as large current cable).

*1 When using the scale with fully closed control

*2 When using the scale with a linear motor

SERVICE NETWORK

*As of January 2019

Europe

Mitutoyo Europe GmbH

Borsigstrasse 8-10, 41469 Neuss, GERMANY
TEL: 49 (0)2137 102-0 FAX: 49 (0)2137 102-351

Mitutoyo CTL Germany GmbH

Von-Gunzert-Strasse 17, 78727 Oberndorf, GERMANY
TEL: 49 (0)7423 8776-0 FAX: 49 (0)7423 8776-99

KOMEG Industrielle Messtechnik GmbH

Zum Wasserwerk 3, 66333 Völklingen, GERMANY
TEL: 49 (0)6898 91110 FAX: 49 (0)6898 911100

Germany

Mitutoyo Deutschland GmbH

Borsigstrasse 8-10, 41469 Neuss, GERMANY
TEL: 49 (0)2137 102-0 FAX: 49 (0)2137 86 85

M3 Solution Center Hamburg

Tempowerkring 9-im HIT-Technologiepark 21079
Hamburg, GERMANY
TEL: 49 (0)40 791894-0 FAX: 49 (0)40 791894-50

M3 Solution Center Berlin

Carl-Scheele-Straße 16, 12489 Berlin, GERMANY
TEL:49(0)30 2611 267

M3 Solution Center Eisenach

Heinrich-Ehrhardt-Platz 1, 99817 Eisenach,GERMANY
TEL: 49 (0)3691 88909-0 FAX: 49 (0)3691 88909-9

M3 Solution Center Ingolstadt

Marie-Curie-Strasse 1a, 85055 Ingolstadt, GERMANY
TEL: 49 (0)841 954920 FAX: 49 (0)841 9549250

M3 Solution Center Leonberg

Steinbeisstrasse 2, 71229 Leonberg, GERMANY
TEL: 49 (0)7152 6080-0 FAX: 49 (0)7152 608060

Mitutoyo-Messgeräte Leonberg GmbH

Heidenheimer Strasse 14, 71229 Leonberg, GERMANY
TEL: 49 (0)7152 9237-0 FAX: 49 (0)7152 9237-29

U.K.

Mitutoyo (UK) Ltd.

Joule Road, West Point Business Park,
Andover, Hampshire SP10 3UX, UNITED KINGDOM
TEL: 44 (0)1264 353 123 FAX: 44 (0)1264 354883

M3 Solution Center Coventry

Unit6, Banner Park, Wickmans Drive, Coventry,
Warwickshire CV4 9XA, UNITED KINGDOM
TEL: 44 (0)2476 426300 FAX: 44 (0)2476 426339

M3 Solution Center Halifax

Lowfields Business Park, Navigation Close, Elland,
West Yorkshire HX5 9HB, UNITED KINGDOM
TEL: 44 (0)1422 375566 FAX: 44 (0)1422 328025

M3 Solution Center East Kilbride

The Baird Building, Rankine Avenue, Scottish
Enterprise Technology Park, East Killbride G75
0QF, UNITED KINGDOM
TEL: 44 (0)1355 581170 FAX: 44 (0)1355 581171

France

Mitutoyo France

Paris Nord 2-123 rue de la Belle Etoile, BP 59267
ROISSY EN FRANCE 95957 ROISSY CDG
CEDEX, FRANCE
TEL: 33 (0)149 38 35 00

M3 Solution Center LYON

Parc Mail 523, cours du 3éme millénaire, 69791
Saint-Priest, FRANCE
TEL: 33 (0)149 38 35 70

M3 Solution Center STRASBOURG

Parc de la porte Sud, Rue du pont du péage,
67118 Geispolsheim, FRANCE
TEL: 33 (0)149 38 35 80

M3 Solution Center CLUSES

Espace Scionzier 480 Avenue des Lacs, 74950
Scionzier, FRANCE
TEL: 33 (0)1 49 38 35 90

M3 Solution Center TOULOUSE

Aeroparc Saint Martin Cellule B08 ZAC de Saint
Martin du Touch 12 rue de Caulet 31300
Toulouse, FRANCE
TEL: 33 (0)1 49 38 42 90

M3 Solution Center RENNES

ZAC Mivoie
Le Vallon
35230 Noyal-Châtillon sur Seiche, FRANCE
TEL: 33 (0)1 49 38 42 10

Italy

MITUTOYO ITALIANA S.r.l.

Corso Europa, 7 - 20020 Lainate (MI), ITALY
TEL: 39 02 935781 FAX: 39 02 9373290•93578255

M3 Solution Center BOLOGNA

Via dei Carpini1/A - 40011 Anzola Emilia (BO), ITALY
TEL: 39 02 93578215 FAX: 39 02 93578255

M3 Solution Center CHIETI

Contrada Santa Calcagna - 66020 Rocca S. Giovanni (CH), ITALY
TEL: 39 02 93578280 FAX: 39 02 93578255

M3 Solution Center PADOVA

Via G. Galilei 21/F - 35035 Mestrino (PD), ITALY
TEL: 39 02 93578268 FAX: 39 02 93578255

Belgium / Netherlands

Mitutoyo BeNeLux

Mitutoyo Belgium N.V.

Hogenakkerhoekstraat 8, 9150 Kruibeke, BELGIUM
TEL: 32 (0)3-2540444 FAX: 32(0)3-2540445

Mitutoyo Nederland B.V.

Wiltonstraat 25, 3905 KW Veenendaal,
THE NETHERLANDS
TEL: 31(0)318-534911

Sweden

Mitutoyo Scandinavia AB

Släntvägen 6, 194 61 Upplands Väsby, SWEDEN
TEL: 46 (0)8 594 109 50 FAX: 46 (0)8 590 924 10

M3 Solution Center Alingsås

Ängsvaktaregatan 3A, 441 38 Alingsås, SWEDEN
TEL: 46 (0)8 594 109 50 FAX:46 (0)322 63 31 62

M3 Solution Center Värnamo

Storgatsbacken 1, 331 30 Värnamo, SWEDEN
TEL: 46 (0)8 594 109 50 FAX: 46 (0)370 463 34

Switzerland

Mitutoyo (Schweiz) AG

Steinackerstrasse 35, 8902 Urdorf, SWITZERLAND
TEL: 41 (0)447361150 FAX: 41(0)447361151

Mitutoyo (Suisse) SA

Rue Galilée 4, 1400 Yverdon-les Bains, SWITZERLAND
TEL: 41 (0)244259422 FAX: 41 (0)447361151

Poland

Mitutoyo Polska Sp.z o.o.

Ul.Graniczna 8A, 54-610 Wroclaw, POLAND
TEL: 48 (0)71354 83 50 FAX: 48 (0)71354 83 55

Czech Republic

Mitutoyo Česko s.r.o.

Dubská 1626, 415 01 Teplice, CZECH REPUBLIC
TEL: 420 417-514-011 FAX: 420 417-579-867

Mitutoyo Česko s.r.o. M3 Solution Center Ivančice

Ke Karlovu 62/10, 664 91 Ivančice, CZECH REPUBLIC
TEL: 420 417-514-011 FAX: 420 417-579-867

Mitutoyo Česko s.r.o. M3 Solution Center Ostrava Mošnov

Mošnov 314, 742 51 Mošnov, CZECH REPUBLIC
TEL: 420 417-514-050 FAX:420 417-579-867

Mitutoyo Česko s.r.o. Slovakia Branch

Hviezdoslavova 124, 017 01 Povážská
Bystrica, SLOVAKIA
TEL: 421 948-595-590

Hungary

Mitutoyo Hungária Kft.

Záhony utca 7, D-épület / fsz, 1031 Budapest, HUNGARY
TEL: 36 (0)1 2141447 FAX: 36 (0)1 2141448

Romania

Mitutoyo Romania SRL

1A Drumul Garii Odai Street, showroom, Ground
Floor, 075100 OTOPENI-ILFOV, ROMANIA
TEL: 40 (0)311012088 FAX: +40 (0)311012089

Showroom in Brasov

Strada Ionescu Crum Nr.1, Brasov Business
Park Turnul 1, Mezanin, 500446
Brasov-Judetul Brasov, ROMANIA
TEL/FAX: 40 (0)371020017

Russian Federation

Mitutoyo RUS LLC

13 Sharikopodshipnikovskaya, bld.2,
115088 Moscow, RUSSIAN FEDERATION
TEL: 7 495 7450 752

Finland

Mitutoyo Scandinavia AB Finnish Branch

Viherkiitäjä 2A, 33960, Pirkkala, FINLAND
TEL: 358 (0)40 355 8498

Austria

Mitutoyo Austria GmbH

Johann Roithner Straße 131 A-4050 Traun, AUSTRIA
TEL: 43 (0)7229 23850 FAX: 43 (0)7229 23850-90

Götzis Regional Showroom

Lasten Straße 48A 6840, AUSTRIA

Singapore

Mitutoyo Asia Pacific Pte. Ltd.

Head office / M3 Solution Center

24 Kallang Avenue, Mitutoyo Building,
SINGAPORE 339415

TEL:(65)62942211 FAX:(65)62996666

Malaysia

Mitutoyo (Malaysia) Sdn. Bhd.

Kuala Lumpur Head Office / M3 Solution Center

Mah Sing Integrated Industrial Park, 4, Jalan Utarid U5/14,
Section U5, 40150 Shah Alam, Selangor, MALAYSIA

TEL:(60)3-78459318 FAX:(60)3-78459346

Penang Branch office / M3 Solution Center

No.30, Persiaran Mahsuri 1/2, Sunway Tunas,
11900 Bayan Lepas, Penang, MALAYSIA

TEL:(60)4-6411998 FAX:(60)4-6412998

Johor Branch office / M3 Solution Center

No. 70, Jalan Molek 1/28, Taman Molek, 81100
Johor Bahru, Johor, MALAYSIA

TEL:(60)7-3521626 FAX:(60)7-3521628

Thailand

Mitutoyo(Thailand)Co., Ltd.

Bangkok Head Office / M3 Solution Center

76/3-5, Chaengwattana Road, Kwaeng Anusaowaree,
Khet Bangkaen, Bangkok 10220, THAILAND

TEL:(66)2-080-3500 FAX:(66)2-521-6136

Chonburi Branch / M3 Solution Center

7/1, Moo 3, Tambon Bowin, Amphur Sriracha,
Chonburi 20230, THAILAND

TEL:(66)2-080-3563 FAX:(66)3-834-5788

Amata Nakorn Branch / M3 Solution Center

700/199, Moo 1, Tambon Bankao, Amphur Phan-
thong, Chonburi 20160, THAILAND

TEL:(66)2-080-3565 FAX:(66)3-846-8978

Indonesia

PT. Mitutoyo Indonesia

Head Office / M3 Solution Center

Jalan Sriwijaya No.26 Desa cibatu Kec. Cikarang
Selatan Kab. Bekasi 17530, INDONESIA

TEL: (62)21-2962 8600 FAX: (62)21-2962 8604

Vietnam

Mitutoyo Vietnam Co., Ltd

Hanoi Head Office / M3 Solution Center

No. 07-TT4, My Dinh - Me Tri Urban Zone, My Dinh 1
Ward, Nam Tu Liem District, Hanoi, VIETNAM

TEL:(84)24-3768-8963 FAX:(84)24-3768-8960

Ho Chi Minh City Branch Office / M3 Solution Center

123 Dien Bien Phu Street,Ward 15,Binh Thanh
District, Ho Chi Minh City, VIETNAM

TEL:(84)28-3840-3489 FAX:(84)28-3840-3498

Mitutoyo Philippines, Inc.

Head Office / M3 Solution Center

Unit 2103, Bldg 2 GMV Building 2, 107 North Main Avenue,
Laguna Technopark, Binan, Laguna 4024, Philippines

TEL:(63)49 544 0272 FAX:(63)49 544 0272

India

Mitutoyo South Asia Pvt. Ltd.

Head Office / M3 Solution Center

C-122, Okhla Industrial Area, Phase-I,
New Delhi-110 020, INDIA

TEL:91(11)2637-2090 FAX:91(11)2637-2636

MSA Gurgaon technical center

Plot No. 65, Phase-IV, Udyog Vihar, Gurgaon – 122016

TEL : 91 (0124) – 2340294

Mumbai Region Head office

303, Sentinel Hiranandani Business Park Powai,
Mumbai-400 076, INDIA

TEL:91(22)2570-0684, 837, 839 FAX:91(22)2570-0685

Pune Office / M3 Solution Center

G2/G3, Pride Kumar Senate, F.P. No. 402 Off.
Senapati Bapat Road, Pune-411 016, INDIA

TEL:91(20)6603-3643, 45, 46 FAX:91(20)6603-3644

Bengaluru Region Head office / M3 Solution Center

No. 5, 100 Ft. Road, 17th Main, Koramangala,
4th Block, Bengaluru-560 034, INDIA

TEL:91(80)2563-0946, 47, 48 FAX:91(80)2563-0949

Chennai Office / M3 Solution Center

No. 624, Anna Salai Teynampet, Chennai-600 018, INDIA

TEL:91(44)2432-8823, 24, 27, 28

FAX:91(44)2432-8825

Kolkata Office

Unit No. 1208,Om Tower, 32,J.L..Nehru Road,
Kolkata-700 071, INDIA

Tel: 91 33-22267088/40060635 Fax: (91) 33-22266817

Ahmedabad Office/M3 Solution Center (Ahmedabad)

A-104 & A-105, First Floor, Solitaire Corporate
Park, Near Divya Bhaskar Press, S.G. Road,
Ahmedabad - 380 015, INDIA

TEL: (91) 079 - 29704902/903

Coimbatore Office (Coimbatore)

Regus, Srivari Srimath, 3rd Floor, Door No:1045,
Avinashi Road, Coimbatore - 641 018,INDIA

TEL: (91) 9345005663

Taiwan

Mitutoyo Taiwan Co., Ltd. / M3 Solution Center Taipei
4F., No.71, Zhouzi St., Neihu Dist., Taipei City 114,
TAIWAN (R.O.C.)
TEL:886(2)5573-5900 FAX:886(2)8752-3267

Taichung Branch / M3 Solution Center Taichung
1F., No.758, Zhongming S. Rd., South Dist.,
Taichung City 402, TAIWAN(R.O.C.)
TEL:886(4)2262-9188 FAX:886(4) 2262-9166

Kaohsiung Branch / M3 Solution Center Kaohsiung
1F., No.31-1, Haibian Rd., Lingya Dist.,
Kaohsiung City 802, TAIWAN (R.O.C.)
TEL:886(7)334-6168 FAX:886(7)334-6160

South Korea

Mitutoyo Korea Corporation
Head Office / M3 Solution Center
(Sanbon-Dong, Geumjeong High View Build.), 6F, 153-8,
Ls-Ro, Gunpo-Si, Gyeonggi-Do, 15808 KOREA
TEL:82(31)361-4200 FAX:82(31)361-4202

Busan Office / M3 Solution Center
(3150-3, Daejeo 2-dong) 8,Yutongdanji 1-ro
49beon-gil, Gangseo-gu, Busan, 46721 KOREA
TEL:82(51)718-2140 FAX:82(51)324-0104

Daegu Office / M3 Solution Center
(Galsan-dong, Daegu Business Center), 301-Ho, 217,
Seongseogongdan-ro, Dalseo-gu, Daegu 42704 KOREA
TEL:82(53)593-5602 FAX:82(53)593-5603

China

Mitutoyo Measuring Instruments (Shanghai) Co., Ltd.
12F, Nextage Business Center, No.1111
Pudong South Road, Pudong New District,
Shanghai 200120, CHINA
TEL:86(21)5836-0718 FAX:86(21)5836-0717

Suzhou Office / M3 Solution Center (Suzhou)
No. 46 Baiyu Road, Suzhou 215021, CHINA
TEL:86(512)6522-1790 FAX:86(512)6251-3420

Wuhan Office
Room 1701, Wuhan Wanda Center, No. 96,
Linjiang Road, Wuchang District, Wuhan
Hubei 430060, CHINA
TEL:86(27)8544-8631 FAX:86(27)8544-6227

Chengdu Office
1-701, New Angle Plaza, 668# Jindong Road,
Jinjiang District, Chengdu, Sichuan 610066, CHINA
TEL:86(28)8671-8936 FAX:86(28)8671-9086

Hangzhou Office

Room 804, Eastern International Business Center
Building 1, No.600 Jinsha Road
Hangzhou Economic and Technological
Development Zone, 310018, CHINA
TEL: 86(571)8288-0319 FAX: 86(571)8288-0320

Tianjin Office / M3 Solution Center Tianjin
Room D 12/F, TEDA Building, No.256 Jie-fang
Nan Road Hexi District, Tianjin 300042, CHINA
TEL:86(22)5888-1700 FAX:86(22)5888-1701

Changchun Office
Room 815, 8F, Building A1, Upper East
International No.3000 Dongsheng Street,
Erdao District, Changchun, Jilin, 130031, CHINA
TEL:86(431)8192-6998 FAX:86(431)8192-6998

Chongqing Office
Room 1312, Building 3, Zhongyu Plaza, No.86,
Hongjin Avenue, Longxi Street, Yubei District,
Chongqing, 400000, CHINA
TEL:86(23)6595-9950 FAX:86(23)6595-9950

Qingdao Office
Room 638, 6F, No.192 Zhengyang Road, Chengyang
District, Qingdao, Shandong, 266109, CHINA
TEL:86(532)8096-1936 FAX:86(532)8096-1937

Xi'an Office
Room 805, Xi'an International Trade Center, No.
196 Xiaozhai East Road, Xi'an, 710061, CHINA
TEL:86(29)8538-1380 FAX:86(29)8538-1381

Dalian Office / M3 Solution Center Dalian
Room 1008, Grand Central IFC, No.128 Jin ma Road,
Economic Development Zone, Dalian 116600, CHINA
TEL:86(411)8718 1212 FAX:86(411)8754-7587

Zhengzhou Office
Room1801,18/F,Unit1,Building No.23, Shangwu Inner
Ring Road, Zhengdong New District, Zhengzhou City,
Henan Province, 450018, CHINA
TEL:86(371)6097-6436 FAX:86(371)6097-6981

Mitutoyo Leepport Metrology (Hong Kong) Limited
Room 818, 8/F, Vanta Industrial Centre, No.21-33, Tai
Lin Pai Road, Kwai Chung, NT, Hong Kong
TEL:86(852)2992-2088 FAX:86(852)2670-2488

Mitutoyo Leepport Metrology (Dongguan) Limited / M3 Solution Center Dongguan
No.26, Guan Chang Road, Chong Tou Zone,
Chang An Town, Dong Guan, 523855 CHINA
TEL:86(769)8541 7715 FAX:86(769)-8541 7745

Mitutoyo Leepport Metrology (Dongguan) Limited – Fuzhou office

Room 2104, City Commercial Centre, No.129 Wu Yi Road N., Fuzhou City, Fujian Province, CHINA
TEL 86 591 8761 8095 FAX 86 591 8761 8096

Mitutoyo Leepport Metrology (Dongguan) Limited –Changsha office

Room 2207, Shiner International Plaza, No. 88, Kaiyuan Middle Road, Changsha City, Hunan, China
TEL 86 731 8401 9276 FAX 86 731 8401 9376

Mitutoyo Measuring Instruments (Suzhou) Co., Ltd.

No. 46 Baiyu Road, Suzhou 215021, CHINA
TEL:86(512)6252-2660 FAX:86(512)6252-2580

U.S.A.

Mitutoyo America Corporation

965 Corporate Boulevard, Aurora, IL 60502, U.S.A.
TEL:1-(630)820-9666 Toll Free No. 1-(888)648-8869
FAX:1-(630)978-3501

M3 Solution Center-Illinois

965 Corporate Boulevard, Aurora, IL 60502, U.S.A.
TEL:1-(888)648-8869 FAX:1-(630)978-3501

M3 Solution Center-Ohio

6220 Hi-Tek Court, Mason, OH 45040, U.S.A.
TEL:1-(888)648-8869 FAX:1-(513)754-0718

M3 Solution Center-Michigan

46850 Magellan Drive, Suite 100, Novi, MI 48377, U.S.A.
TEL:1-(888)648-8869 FAX: 1-(248)926-0928

M3 Solution Center-California

16925 E. Gale Avenue, City of Industry, CA 91745, U.S.A.
TEL:1-(888)648-8869 FAX:1-(626)369-3352

M3 Solution Center-North Carolina

11515 Vanstory Drive, Suite 140, Huntersville, NC 28078, U.S.A.
TEL:1-(888)648-8869 FAX:1-(704)875-9273

M3 Solution Center-Alabama

2100 Riverchase Center, Suite 106, Hoover, AL 35244, U.S.A.
TEL:1-(888)648-8869 FAX:1-(205)988-3423

M3 Solution Center-Washington

1000 SW 34th Street Suite G, Renton, WA 98057 U.S.A.
TEL:1-(888)648-8869

M3 Solution Center-Texas

4560 Kendrick Plaza Drive, Suite 120, Houston, TX 77032, U.S.A.
TEL:1-(888)648-8869 FAX:1-(281)227-0937

M3 Solution Center-Massachusetts

753 Forest Street, Suite 110, Marlborough, MA 01752, U.S.A.
TEL:1-(888)648-8869 FAX:1-(508)485-0782

Mitutoyo America Corporation Calibration Lab

965 Corporate Boulevard, Aurora, IL 60502, U.S.A.
TEL:1-(888)648-8869 FAX:1-(630)978-6477

Micro Encoder, Inc.

11533 NE 118th Street, Kirkland, WA 98034-7111, U.S.A.
TEL:1-(425)821-3906 FAX:1-(425)821-3228

Micro Encoder Los Angeles, Inc.

16925 E. Gale Avenue, City of Industry, CA 91745-1806 U.S.A.
TEL: 1-626-961-9661 FAX:1-626-333-8019

Canada

Mitutoyo Canada Inc.

2121 Meadowvale Blvd., Mississauga, Ont. L5N 5N1., CANADA
TEL:1-(905)821-1261 FAX:1-(905)821-4968

Montreal Office

7075 Place Robert-Joncas Suite 129, Montreal, Quebec H4M 2Z2, CANADA
TEL:1-(514)337-5994 FAX:1-(514)337-4498

Brazil

Mitutoyo Sul Americana Ltda.

Head office / M3 Solution Center / Factory
Rodovia Índio Tibiriça 1555, Bairro Raffo, CEP 08655-000 Suzano – SP, Brasil
TEL:55 (11)5643-0040

Argentina

Mitutoyo Sul Americana Ltda.

Argentina Branch / M3 Solution Center
Av. B. Mitre 891/899 – C.P. (B1603CQI)
Vicente López –Pcia. Buenos Aires – Argentina
TEL:54(11)4730-1433 FAX:54(11)4730-1411

Sucursal Cordoba / M3 Solution Center

Av. Amadeo Sabattini, 1296, esq. Madrid B° Crisol Sur – CP 5000, Cordoba, ARGENTINA
TEL/FAX:54 (351) 456-6251

Mexico**Mitutoyo Mexicana, S.A. de C.V.**

Prolongación Industria Eléctrica No. 15 Parque Industrial Naucalpan

Naucalpan de Juárez, Estado de México C.P. 53370, MÉXICO

TEL: 52 (01-55) 5312-5612

Monterrey Office / M3 Solution Center Monterrey

Blv. Interamericana No. 103, Parque Industrial FINSA, C.P. 66636 Apodaca, N.L., MÉXICO

TEL: 52(01-81) 8398-8227/8228/8242/8244

FAX: 52(01-81) 8398-8226

Tijuana Office / M3 Solution Center Tijuana

Calle José María Velazco 10501-C, Col. Cd. Industrial Nueva Tijuana, C.P. 22500 Tijuana, B.C., MÉXICO

TEL: 52 (01-664) 647-5024

Querétaro Office / M3 Solution Center Querétaro

Av. Cerro Blanco No.500-1, Colonia Centro Sur, Querétaro, Querétaro, C.P. 76090, MÉXICO

TEL: 52 (01-442) 340-8018, 340-8019 and 340-8020

FAX: 52 (01-442) 340-8017

Mitutoyo Mexicana, S.A. de C.V. Querétaro Calibration Laboratory

Av. Cerro Blanco 500 30 Centro Sur, Querétaro, Querétaro, C.P. 76090, MÉXICO

TEL: 52 (01-442) 340-8018, 340-8019 and 340-8020

FAX: 52 (01-442) 340-8017

Aguascalientes Office / M3 Solution Center

Av. Aguascalientes No. 622, Local 15 Centro Comercial El Cilindro Fracc. Pulgas Pandas Norte, C.P. 20138, Aguascalientes, Ags. MÉXICO

TEL: 52 (01-449) 174-4140 and 174-4143

Irapuato Office / M3 Solution Center

Boulevard a Villas de Irapuato No. 1460 L.1 Col. Ejido Irapuato C.P. 36643

Irapuato, Gto., MÉXICO

TEL: 52 (01-462) 144-1200 and 144-1400

Revision Record

Date of publication	Revision status	Details of revision
November 1, 2018	Revised first edition	Completely revised and issued
February 1, 2020	Revised second edition	Correspond to product specification changes

EU Declaration of Conformity

Mitutoyo Corporation

20-1, Sakado 1-Chome, Takatsu-ku, Kawasaki-shi, Kanagawa 213-8533, Japan
Tel: +81 (0)44 813-8230 Fax: +81 (0)44 813-8231
Home page: <http://www.mitutoyo.co.jp/global.html>

For the EU Directive, Authorized representative and importer in the EU:
Mitutoyo Europe GmbH
Borsigstrasse 8-10, 41469 Neuss, Germany

Printed in Japan

No. 99MBE073B