

High-Precision Digital Height Gauge QM-Height

QMH-350AX

QMH-350BX

QMH-600AX

QMH-600BX

QMH-14"AX

QMH-14"BX

QMH-24"AX

QMH-24"BX



User's Manual - Instructions for use -

Read this document thoroughly before operating the product.
After reading, retain it close at hand for future reference.
This English language version of the document contains
the original instructions.

No. 99MAF600B1

Date of publication: April 1, 2020 (1)



■ Product names and model numbers covered in this document

Product name	Model number
High-Precision Digital Height Gauge QM-Height	QMH-350AX QMH-350BX QMH-600AX QMH-600BX QMH-14"AX QMH-14"BX QMH-24"AX QMH-24"BX



■ Notice regarding this document

- Mitutoyo Corporation assumes no responsibilities for any damage to the product, caused by its use not conforming to the procedure described in this document.
- Upon loan or transfer of this product, be sure to attach this document to the product.
- In the event of loss or damage to this document, immediately contact a Mitutoyo sales office or your dealer.
- Read this document thoroughly before operating the product. In particular, be sure to fully understand "Safety Precautions" and "Precautions for Use" in the preface.
- The contents of this document are based on information current as of April, 2020.
- No part or whole of this document may be transmitted or reproduced by any means without prior written permission of Mitutoyo Corporation.
- Some screen displays in this document may be highlighted, simplified or partially omitted for convenience of explanation. In addition, some of them may differ from actual ones to the extent that no user will misunderstand the functions and operations.
- The corporation, organization and product names that appear in this document are their trademarks or registered trademarks.



©2018-2020 Mitutoyo Corporation. All rights reserved.

Conventions and Wording Used in This Document

■ Safety reminder conventions and wording warning against potential hazards

 WARNING	Indicates a hazard with a medium level of risk which, if not avoided, could result in death or serious injury .
 CAUTION	Indicates a hazard with a low level of risk which, if not avoided, could result in minor or moderate injury .
 NOTICE	Indicates a potentially hazardous situation which, if not avoided, may result in property damage .

■ Conventions indicating prohibited and mandatory actions

	Indicates concrete information about prohibited actions.
	Indicates concrete information about mandatory actions.

■ Conventions and wording indicating referential information or reference location

Tips

Indicates further information and details relevant for the operating methods and procedures that are explained in that section.



Indicates reference location if there is information that should be referred to in this document or an extraneous User's Manual.

E.g.: For details about XX, see  "1.2 Names and Functions of Each Part" on page 2.

Safety Precautions

Read these "Safety Precautions" thoroughly before operating the product to use it properly. These safety precautions include such information as to prevent injury to the operator and other persons, damage to property and product defects. Be sure to observe these precautions carefully.

WARNING



- Do not disassemble or modify this product. Doing so can result in fire or electric shock.
- Do not place containers with water, such as flower pots, near this product. If water gets into the device, a fire or electric shock may occur. If water does get into the device, turn off the power, and contact us. Continuing to use the device may result in a fire or electric shock.
- Do not use the device in areas where volatile gases may be released. Doing so can result in a fire.

CAUTION



- This product is heavy. Do not allow it to be lifted or moved by only one person.
- Do not place the product on an unstable surface. It may fall or topple over, causing an injury.
- Do not charge or disassemble the accompanying batteries. They may short circuit.



- This product is heavy. Wear safety shoes. Slippers must not be worn when transporting or installing the product.
- When installing the product on a surface plate, be careful not to pinch your fingers with the base.
- The product may cause injury if it falls down or over. Handle with care.

NOTICE



Do not apply an external voltage to the product with a device such as an electric engraver. Doing so may lead to damage or malfunction.



- If the device will not be used for an extended period of time, remove the batteries. Battery leakage can damage the device.
- Only use LR6 (AA alkaline) or Ni-MH (nickel metal hydride) batteries. Handle the batteries according to their instructions.

Precautions for Use

■ Use and handling of the product

- This product is a measuring instrument.

Do not use this product for any purposes other than measuring.

- This product is for industrial usage.

Do not use this product for purposes other than for industrial usage.

- The product is a precision instrument.

Handle this product with care. Do not apply excessive shock or force to any of the parts during operation.

■ Environment for placement

Use the product in the following places.

- Where there is minimal dust and grit
- Where there are minimal vibrations
- Where the ambient temperature is from 0 °C through 40 °C (from 10 °C through 40 °C when the battery is used)
(For precision measurements, the temperature should be consistently around 20 °C.)
- An operating environment with humidity from 20 %RH through 80 %RH
- On a surface plate

Avoid using the product in the following places.

- Where directly exposed to cutting oil, water, etc.
- Where exposed to direct sunlight, hot air or cold air
- Where instruments generating electromagnetic noise, such as a welding machine or electric discharge machine, are used.

■ Maintenance

- Do not use detergents or organic solvents such as thinners or benzine.
For details about cleaning method, see  "5 Maintenance" on page 61.
- In order to prevent dirt and dust accumulation on the main unit, we recommend covering it with the supplied product cover after use.

■ Power supply

- After use, please be sure to turn off the power.
- Do not connect the AC adapter (optional accessory) to a high-current power supply used by machine tools or large CNC measuring instrument.
- When the power supply to the product is terminated by removing the battery or unplugging the AC adapter (optional accessory), the following data will be erased.
 - Reference (INC measurement system)
📖 "■ Setting the reference (INC measurement system)" on page 16
 - Reference values set for measuring the difference between two points
📖 "3.1.2 Calculating the Difference between the Current Measurement Value and a Set Reference" on page 35
 - Measurement values stored in the memory
📖 "3.1.3 Calculating the Difference between Two Measurement Values Stored in Memory" on page 37

Electromagnetic Compatibility (EMC)

This product complies with the EU EMC Directive. Note that in environments where electromagnetic interference exceeds EMC requirements defined in this directive, appropriate countermeasures are required to assure the product performance.

This product is an industrial product, and is not intended to be used in residential environment. If this product is used in residential environment, this product may cause electromagnetic interference with other instruments. In such a case, it is required to take appropriate measures for preventing such electromagnetic interference.

Export Control Compliance

This product falls into the Catch-All-Controlled Goods and/or Catch-All-Controlled Technologies (including Programs) under Category 16 of Appended Table 1 of Export Trade Control Order or under Category 16 of Appended Table of Foreign Exchange Control Order, based on Foreign Exchange and Foreign Trade Act of Japan.

If you intend re-export of the product from a country other than Japan, re-sale of the product in a country other than Japan, or re-providing of the technology (including Programs), you shall observe the regulations of your country.

Also, if an option is added or modified to add a function to this product, this product may fall under the category of List-Control Goods, List-Control Technology (including Programs) under Category 1 - 15 of Appended Table 1 of Export Trade Control Order or under Category 1 - 15 of Appended Table of Foreign Exchange Control Order, based on Foreign Exchange and Foreign Trade Act of Japan. In that case, if you intend re-export of the product from a country other than Japan, re-sale of the product in a country other than Japan, or re-providing of the technology (including Programs), you shall observe the regulations of your country. Please contact Mitutoyo in advance.

Notes on Export to EU Member Countries

When you intend exporting of this product to any of the EU member countries, it may be required to provide User's Manual(s) in English and EU Declaration of Conformity in English (under certain circumstances, User's Manual(s) in the destination country's official language and EU Declaration of Conformity in the destination country's official language). For detailed information, please contact Mitutoyo in advance.

Disposal of Products outside the European Union and Other European Countries

Please follow the official instruction in each community and country.

Disposal of Old Electrical & Electronic Equipment (Applicable in the European Union and Other European Countries with Separate Collection Systems)



This symbol on the product or on its packaging is based on WEEE Directive (Directive on Waste Electrical and Electronic Equipment), which is a regulation in EU member countries, and this symbol indicates that this product shall not be treated as household waste.



To reduce the environmental impact and minimize the volume of landfills, please cooperate in reuse and recycle.

For how to dispose of the product, please contact your dealer or the nearest Mitutoyo sales office.

Disposal of Waste Batteries and Accumulators (Applicable in the European Union and Other European Countries with Separate Collection Systems)



Batteries and accumulators containing heavy metals such as mercury, lead, and cadmium may contaminate the environment if improperly discarded. When incinerated, certain chemicals are released into the air or concentrated in the ash residue from the combustion process; this may lead to a health risk to humans, animals and the environment in general.

In compliance with legal requirements, the symbol of a 'crossed-out wheeled bin' is either applied on the battery or on its packaging. This symbol indicates that disposal of the batteries in household waste is strictly prohibited; instead the batteries have to be disposed of by separate collection and recycling means. Additional marking identifies the heavy metal content (i.e. Cd = cadmium, Hg = mercury, Pb = lead) as contained within the battery if over prescribed levels.

End users are obliged by law to comply with the discarding procedure for waste batteries. At Mitutoyo facilities, or at its appointed distributors, receptacles will be provided to accept, at no charge, the disposal of previously supplied batteries.

China RoHS Compliance Information

This product meets China RoHS requirements. See the table below.

产品中有害物质的名称及含量

部件名称	有害物质					
	铅 (Pb)	汞 (Hg)	镉 (Cd)	六价铬 (Cr(VI))	多溴联苯 (PBB)	多溴二苯醚 (PBDE)
本体	×	○	○	○	○	○
配件	○	○	○	○	○	○

本表格依据 SJ/T 11364 的规定编制。

○: 表示该有害物质在该部件所有均质材料中的含量均在 GB/T 26572 规定的限量要求以下。

×: 表示该有害物质至少在该部件的某一均质材料中的含量超出 GB/T 26572 规定的限量要求。



环保使用期限标识是根据《电器电子产品有害物质限制使用管理办法》以及《电子电气产品有害物质限制使用标识要求(SJ/T11364-2014)》制定的,适用于中国境内销售的电子电气产品的标识。

电器电子产品只要按照安全及使用说明内容在正常使用情况下,从生产日期算起,在此期限内产品中含有的有毒有害物质不致发生外泄或突变,不致对环境造成严重污染或对其人身、财产造成严重损害。

产品使用后,要废弃在环保使用年限内或者刚到年限的产品,请根据国家标准采取适当的方法进行处置。

另外,此期限不同于质量/功能的保证期限。

Warranty

This product has been manufactured under strict quality management, but should it develop problems within one year of the date of purchase in normal use, repair shall be performed free of charge. Please contact the agent where you purchased the product or Mitutoyo sales representative (☎ "SERVICE NETWORK" on page App-1).

If this product fails or is damaged for any of the following reasons, it will be subject to a repair charge, even if it is still under warranty.

- Failure or damage owing to fair wear and tear
- Failure or damage owing to inappropriate handling, maintenance or repair, or to unauthorized modification
- Failure or damage owing to transport, dropping, or relocation of the product after purchase
- Failure or damage owing to fire, salt, gas, abnormal voltage, lightning surge, or natural disaster
- Failure or damage owing to use in combination with hardware or software other than those designated or permitted by Mitutoyo
- Failure or damage owing to use in ultra-hazardous activities

This warranty is effective only where the product is properly installed and operated in conformance with the instructions in this document within the original country of the installation.

EXCEPT AS SPECIFIED IN THIS WARRANTY, ALL EXPRESS OR IMPLIED CONDITIONS, REPRESENTATIONS, AND WARRANTIES OF ANY NATURE WHATSOEVER INCLUDING, WITHOUT LIMITATION, ANY IMPLIED WARRANTY OF MERCHANTABILITY, FITNESS FOR A PARTICULAR PURPOSE, NONINFRINGEMENT OR WARRANTY ARISING FROM A COURSE OF DEALING, USAGE, OR TRADE PRACTICE, ARE HEREBY EXCLUDED TO THE MAXIMUM EXTENT ALLOWED BY APPLICABLE LAW.

You assume responsibility for all results due to the selection of this product to achieve your intended results.

Disclaimer

IN NO EVENT WILL MITUTOYO, ITS AFFILIATED AND RELATED COMPANIES AND SUPPLIERS BE LIABLE FOR ANY LOST REVENUE, PROFIT, OR DATA, OR FOR SPECIAL, DIRECT, INDIRECT, CONSEQUENTIAL, INCIDENTAL, OR PUNITIVE DAMAGES HOWEVER CAUSED AND REGARDLESS OF THE THEORY OF LIABILITY ARISING OUT OF THE USE OF OR INABILITY TO USE THIS PRODUCT EVEN IF MITUTOYO OR ITS AFFILIATED AND RELATED COMPANIES AND/OR SUPPLIERS HAVE BEEN ADVISED OF THE POSSIBILITY OF SUCH DAMAGES.

If, notwithstanding the foregoing, Mitutoyo is found to be liable to you for any damage or loss which arises out of or is in any way connected with use of this product by you, in no event shall Mitutoyo's and/or its affiliated and related companies' and suppliers' liability to you, whether in contract, tort (including negligence), or otherwise, exceed the price paid by you for the product only.

The foregoing limitations shall apply even if the above-stated warranty fails of its essential purpose. BECAUSE SOME COUNTRIES, STATES OR JURISDICTIONS DO NOT ALLOW THE EXCLUSION OR THE LIMITATION OF LIABILITY FOR CONSEQUENTIAL OR INCIDENTAL DAMAGES, IN SUCH COUNTRIES, STATES OR JURISDICTIONS, MITUTOYO'S LIABILITY SHALL BE LIMITED TO THE EXTENT PERMITTED BY LAW.

About This Document

■ Positioning of this document, document map

This describes the positioning of this document and its relationship with other installments.

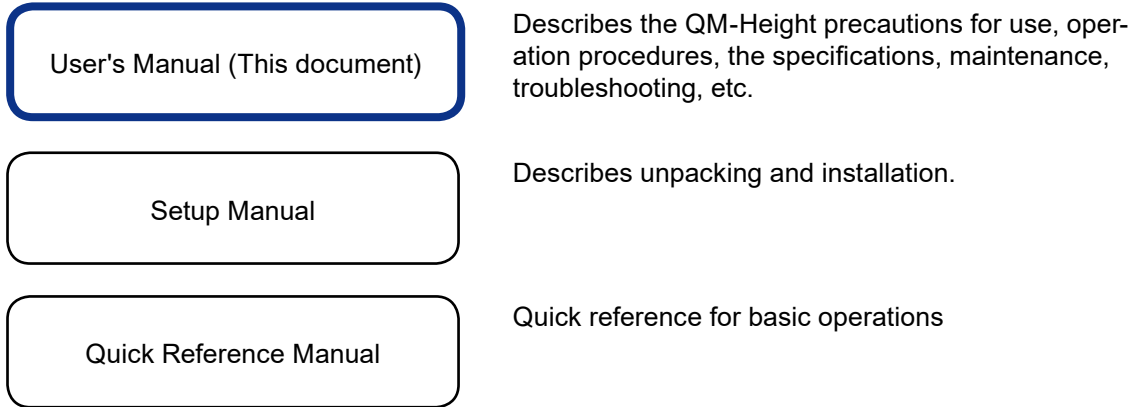

■ Intended readers and purpose of this document

● Intended readers

This document is intended for beginners of the High-Precision Digital Height Gauge.

The readers are assumed to have been familiar with basic operations on a PC and Windows.

They are also assumed to be able to understand individual instructions by reading the described drawings.

● Purpose

This document is aimed at understanding how to use the High-Precision Digital Height Gauge to perform basic measurements and specific usage , applications.

■ How to read this document

2 Basic Measuring Methods

2.4 Measuring the Inside Diameter

A video about inside diameter measurements can be viewed.

Measure the diameter (inside diameter) of a hole. By scanning the upper and lower surfaces of a hole with the stylus, the peak points can be detected. The diameter is calculated from the difference. The diameter of a semicircle where part of the top or bottom of the hole is missing cannot be obtained. This section explains the measurement procedure using the surface plate as the origin (ABS measurement system).

1 Check the setting for the termination method of the scanning measurement (automatic termination or manual termination).
For details about the setup method, see "3.3 Setting the Termination Method of Scanning Measurement" on page 44.

Tips
The operation in step 4 differs for "automatic termination" and "manual termination".

2 Set the surface plate as the origin (ABS measurement system).
For details about the setup, see "2.1.1 Setting the Origin and the Reference" on page 12.

3 Press [Inside diameter measurement].
An icon will be displayed in the upper left of the LCD.

4 Detect the lowest point of the hole.

- If [Auto] (automatic termination) is set, ensure that the stylus is positioned to pass through the lowest point of the hole. When the stylus is raised about 0.5 mm from the lowest point of the hole, a beep sound will be made, and the peak-point detection will automatically terminate.
- Bring the stylus into contact within 0.5 mm of the lowest point. Measuring with a wider range may increase measurement errors.

1 Turn the probe unit up/down wheel, and slowly bring the stylus into contact near the center of the bottom surface of the hole until there is a "beep" sound (keep the stylus in contact with the surface).

[0.000] will be displayed on the LCD.

No. 99MAF600B **24**

An operation video can be viewed.

Indicates the order and the contents of tasks.

Indicates supplementary information.

The sentence with ">>" mark at the head indicates the operation result.

■ Brackets, quotation marks and numbers (1, 1)

The meanings of brackets, quotation marks and numbers to be used in this document are as follows.

() : Round brackets	Represent a paraphrase of an immediately preceding phrase or a supplementary explanation.
" " : Double quotation marks	Represent a highlighted phrase. They also indicate an index where information to be referenced is described.
[] : Square brackets	Represent a menu name on the screen, screen name, dialog name, button, display item, tab name, or key on the keyboard. They also indicate an item to be purposely entered or selected by the customer.
1, 2, 3 ... 1, 2, 3...	Indicates the order and the contents of tasks. (1 : indicates main tasks, 1 : indicates detailed tasks)

Contents

Conventions and Wording Used in This Document	i
Safety Precautions	ii
Precautions for Use	iii
Electromagnetic Compatibility (EMC)	iv
Export Control Compliance	iv
Notes on Export to EU Member Countries	iv
Disposal of Products outside the European Union and Other European Countries ...	v
Disposal of Old Electrical & Electronic Equipment (Applicable in the European Union and Other European Countries with Separate Collection Systems)	v
Disposal of Waste Batteries and Accumulators (Applicable in the European Union and Other European Countries with Separate Collection Systems)	v
China RoHS Compliance Information	vi
Warranty	vii
Disclaimer	vii
About This Document	viii
Contents	x
1 Before Using This Product	1
1.1 Product Capabilities	1
1.2 Names and Functions of Each Part	2
1.2.1 Main Unit	2
1.2.2 Display Unit	4
1.3 Basic Operations	7
1.3.1 Turning the Power On and Off	7
1.3.2 Moving the Main Unit	8
1.3.3 Moving the Probe Unit	10
2 Basic Measuring Methods	11
2.1 Preparing Measurements	12
2.1.1 Setting the Origin and the Reference	12
2.1.2 Setting the Diameter of the Ball on the Tip of the Stylus	18
2.2 Measuring the Height	21
2.3 Measuring Steps and Width	22

2.4	Measuring the Inside Diameter	24
2.5	Measuring the Outside Diameter	27
2.6	Measuring the Plane Displacement (Plane Scanning Measurement)	30
3	Specific Usage Applications	33
3.1	Calculating the Difference between Two Measurement Values.....	33
3.1.1	Calculating the Difference between the Current and Previous Measurement Values ...	34
3.1.2	Calculating the Difference between the Current Measurement Value and a Set Reference ...	35
3.1.3	Calculating the Difference between Two Measurement Values Stored in Memory ...	37
3.2	Judging the Tolerance	40
3.2.1	Setting the Upper and Lower Tolerance Limits	41
3.2.2	Enabling/Disabling the Judgment Function	43
3.3	Setting the Termination Method of Scanning Measurements	44
3.4	Registering the Order of Measurements	45
3.4.1	Measuring Using the Registered Measurement Steps	46
3.5	Setting the Resolution for Measurement Values	48
3.6	Setting the Time until the Power Turns Off (Auto-Off)	49
3.7	Setting the LED Lighting Time	50
3.8	Outputting Measurement Results to an External Device	52
3.8.1	Selecting the Displayed Value to Be Output.....	52
3.8.2	Outputting Data to a Mini Printer (Optional Accessory)	53
3.8.3	Outputting Data to a PC (Windows Only)	55
4	Troubleshooting	57
4.1	If the Following Problem Occurs	57
4.2	If Error Messages Are Displayed	59
5	Maintenance	61
6	Specifications	63
6.1	Basic Specifications	63
6.2	Data Output Specifications	65
6.2.1	Digimatic Data Output	65
6.2.2	USB Data Output Specifications	67
6.3	Accessories	68
6.4	Optional Accessories	69
Index	Index-1
SERVICE NETWORK	App-1

1 Before Using This Product

This chapter explains the product's characteristics, names and functions of each part of the main unit, basic operations, and the settings that must be configured prior to measurement.

1.1 Product Capabilities

This product automatically measures the height of the position. Bring the stylus attached to the detection unit (probe unit) into contact with the workpiece from above or below, and press it against the workpiece until a beep sound is made.

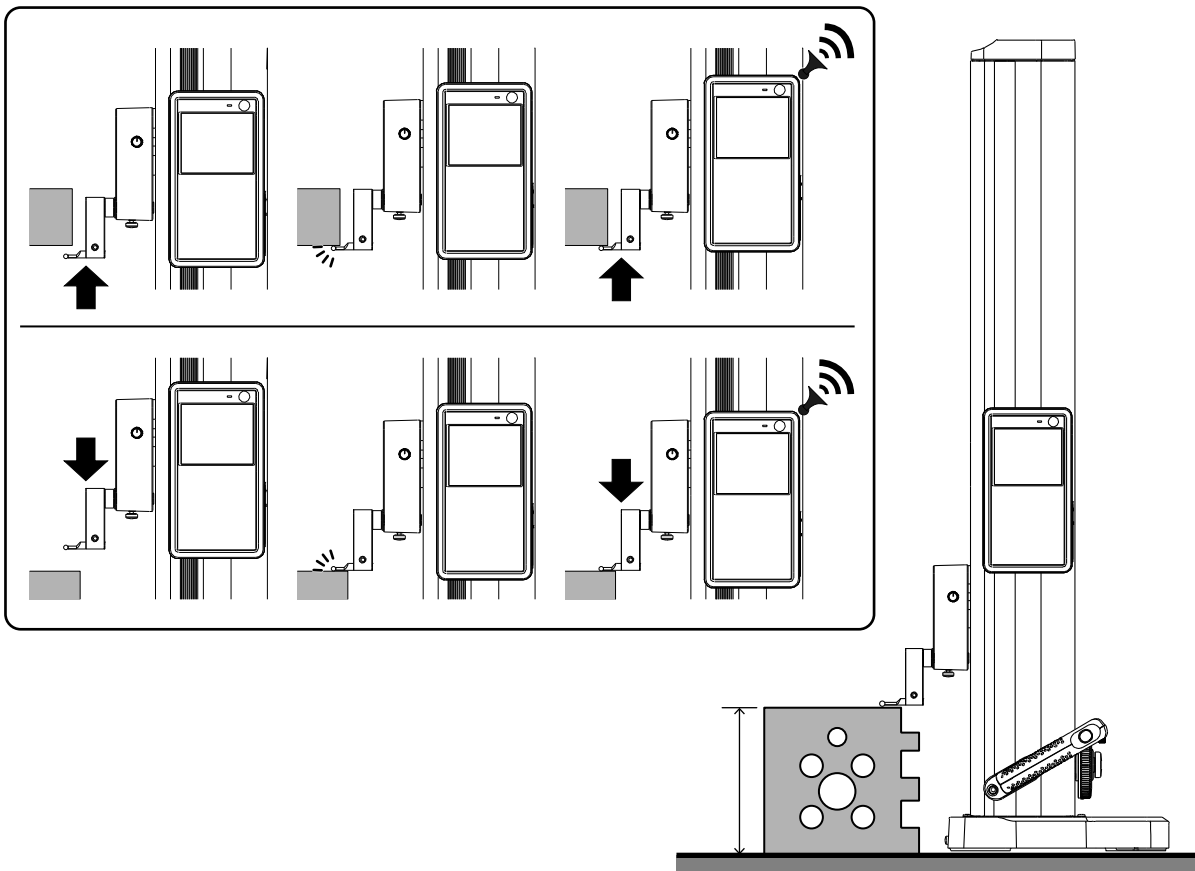

Besides measuring height, the probe unit itself is constructed for free vertical movement within a set range, which enables vertical width measurements, the measurement of the inside diameter of a hole or the outside diameter of a cylinder and the measurement of the run-out of a flat surface (maximum, minimum, displacement) through scanning measurements.

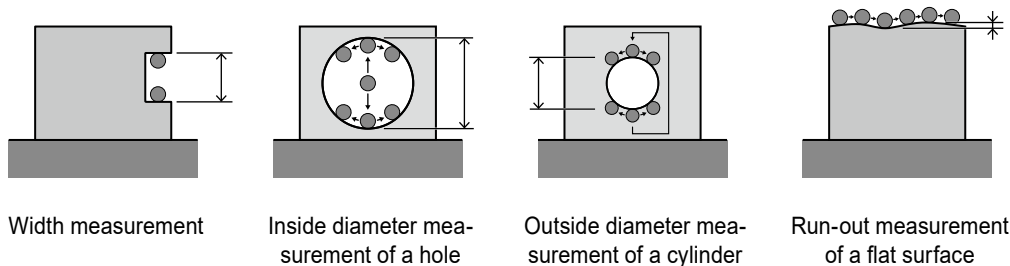

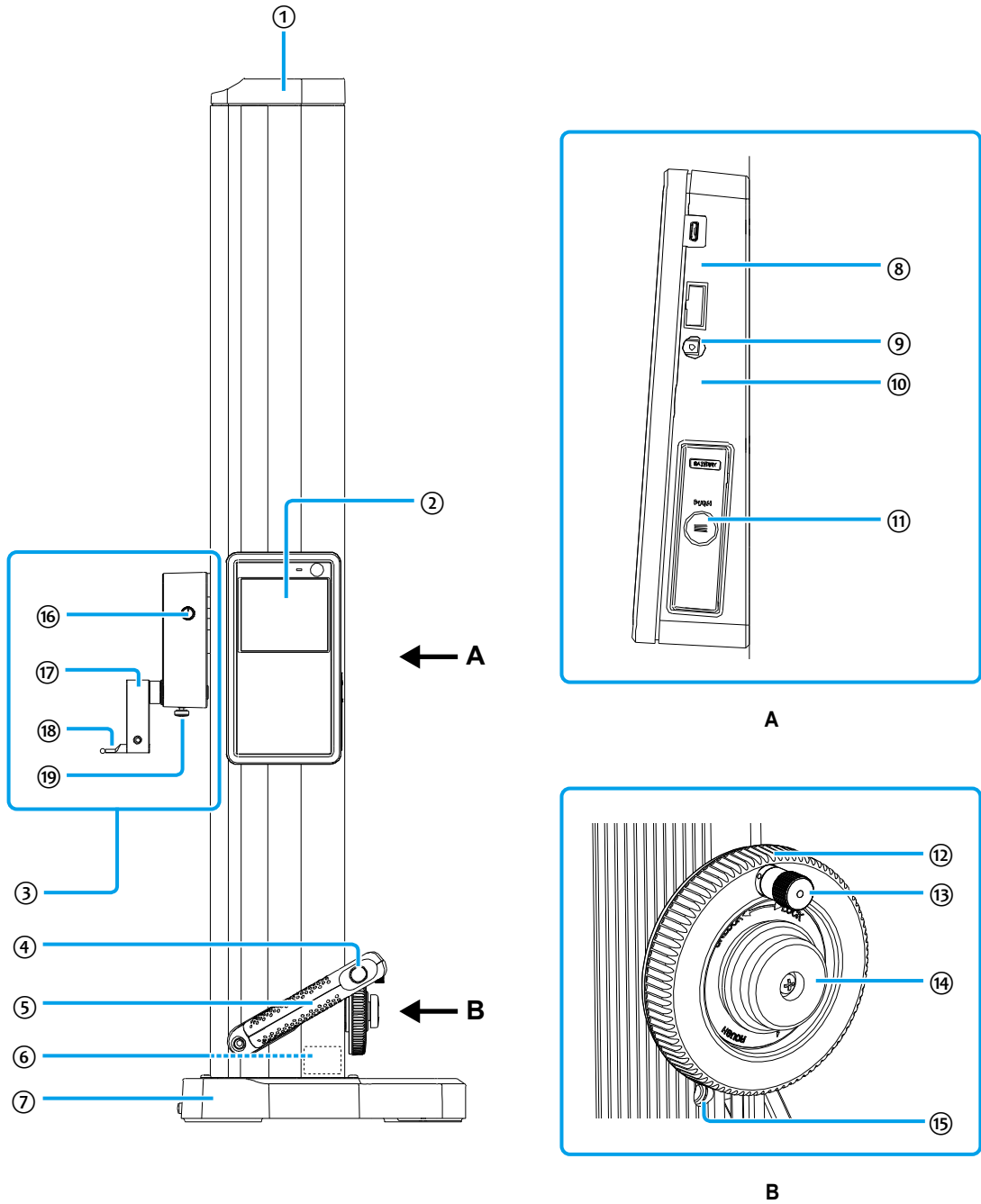

1.2 Names and Functions of Each Part

1.2.1 Main Unit



Number	Name	Functions
①	Head cover	-
②	Display unit	Displays the counted values, measurement values (results), and any messages.

Number	Name	Functions
③	Probe unit	Unit that detects the position of the measuring surface. The ball on the tip of the stylus is brought into contact with the measuring surface, and then the ball is pressed against the measuring surface to detect the position.
④	Air-float switch (QMH-600BX/ QMH-350BX/QMH-24"BX/ QMH-14"BX only)	This switch uses the air-float function to raise the main unit of the product.  Do not execute a measurement with the air-float function active because a measurement error may occur.
⑤	Carrier grip	Gripped when moving the main unit on the surface plate.
⑥	Label	Contains information such as the code number of this product.
⑦	Base	Is in contact with the surface plate when the main unit is installed. Held when moving the main unit on the surface plate.
⑧	Micro USB connector (A/B receptacle)*	Port for connecting a PC with a USB micro A-cable.
⑨	Digimatic output connector*	Port for connecting the Digimatic mini-processor (DP-1 series, optional accessory).
⑩	DC jack*	Jack for connecting an AC adapter (optional accessory).
⑪	Battery case	Case for inserting the batteries.
⑫	Probe unit up/down wheel	When turned, moves the probe unit up and down.  Slowly turn the wheel to avoid malfunction.
⑬	Probe fine adjustment knob	Moves the probe unit slowly when pulled and turned.
⑭	Clamp screw	Fixes the rotational movement of the probe unit up/down wheel.
⑮	Float amount adjustment screw (QMH-600BX/QMH-350BX/ QMH-24"BX/QMH-14"BX only)	Adjusts the amount of airflow when the air-float function is active. Turning it clockwise increases the airflow (amount of the air-float flow), and turning it counterclockwise decreases the airflow.
⑯	Clamp knob	Fixes the free vertical movement of the probe unit itself. Tips • Loosen the knob when using the probe normally. • Tighten the knob when using a lever-type dial gauge (optional accessory).
⑰	Holder	Used to mount and secure the stylus. Tips A lever-type dial gauge (optional accessory) or dial gauge (optional accessory) can be mounted instead of the stylus.
⑱	Stylus	The ball on the tip is brought into contact with the work-piece to perform measurements.
⑲	Holder clamp knob	Secures the inserted holder.

* During use, we recommend securing the cable part with the supplied cable clamp.

1.2.2 Display Unit

■ Operation panel

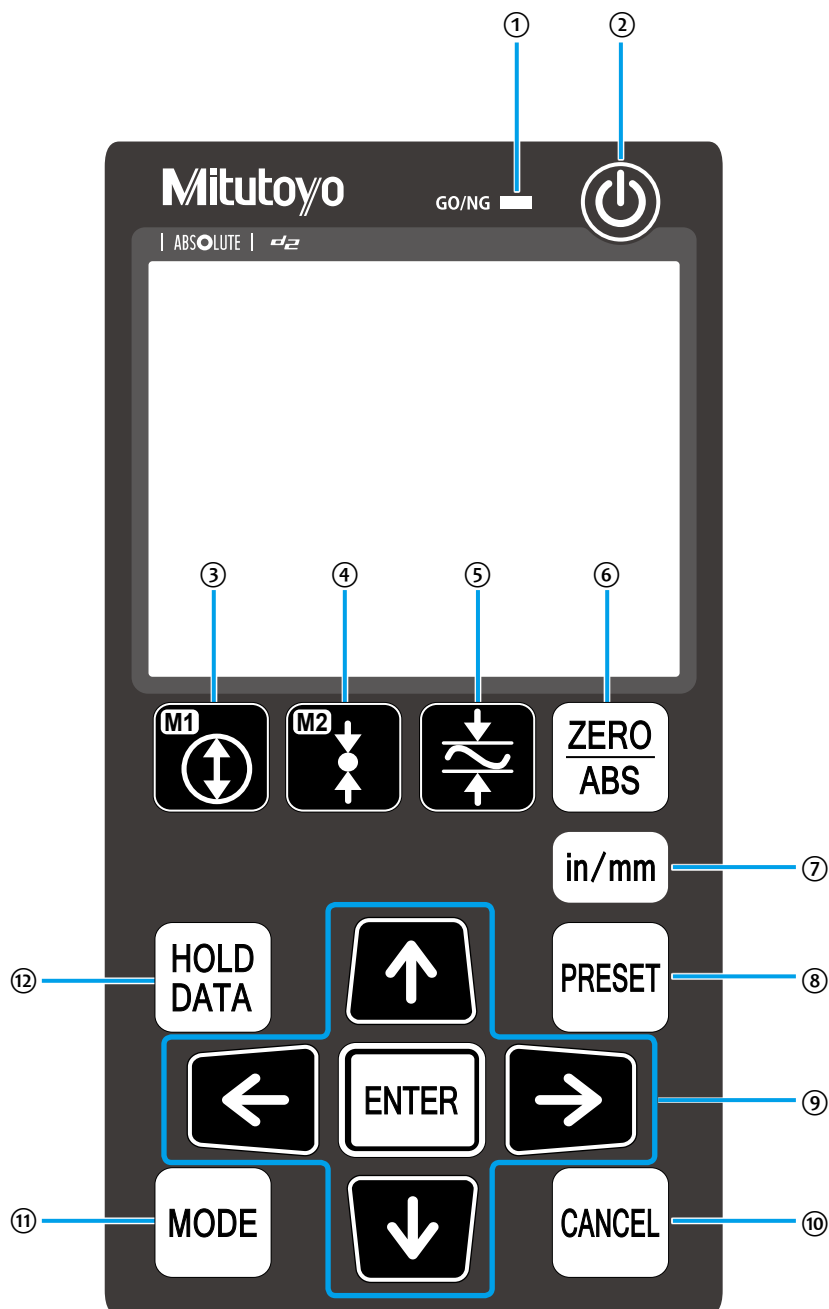

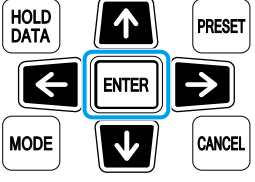
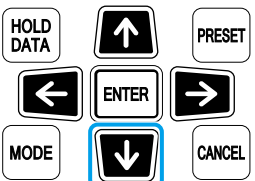
Number	Name	Functions
①	Tolerance judgment results LED	LED lamp that indicates the result of the tolerance judgment. For details, see "3.2 Judging the Tolerance" on page 40.
②	[Power button]	Turns the power on or off.
③	[Inside diameter measurement]	Measures the inside diameter. For details, see "2.4 Measuring the Inside Diameter" on page 24.
④	[Outside diameter measurement]	Measures the outside diameter. For details, see "2.5 Measuring the Outside Diameter" on page 27.
⑤	[Scanning measurement]	Measures the maximum run-out, minimum run-out, and displacement value (maximum – minimum) of a flat surface. For details, see "2.6 Measuring the Plane Displacement (Plane Scanning Measurement)" on page 30.
⑥	[ZERO/ABS]	Switches between the ABS measurement system and the INC measurement system (simultaneously sets the display to zero).
⑦	[in/mm]	Changes the setting for units between inches and millimeters (only on models that support inches).
⑧	[PRESET]	Presets a value for the point of measurement.
⑨	[↑] [→] [↓] [←] [ENTER]	<ul style="list-style-type: none"> Changes numbers and settings. Press [ENTER] to confirm an operation.  <ul style="list-style-type: none"> Press and hold [↓] to change the counting direction. Moving the probe unit upwards decreases the counter value, and moving the probe unit downwards increases the counter value. Press and hold the button again to return to normal.  <p>If you have changed the counting direction, follow "2.1.1 Setting the Origin and the Reference" on page 12 to set the origin again.</p>
⑩	[CANCEL]	Cancels a key operation. Pressed to cancel items such as outside diameter measurements that have been selected with key operations or measurements that are being processed.
⑪	[MODE]	Used to configure settings for a specific application, such as changing the measurement resolution. For details, see "3 Specific Usage Applications" on page 33.
⑫	[HOLD DATA]	Holds the display of a measurement value or outputs the measurement results to external devices. For details about outputting data to external devices, see "3.8 Outputting Measurement Results to an External Device" on page 52.

■ Liquid crystal display (LCD)

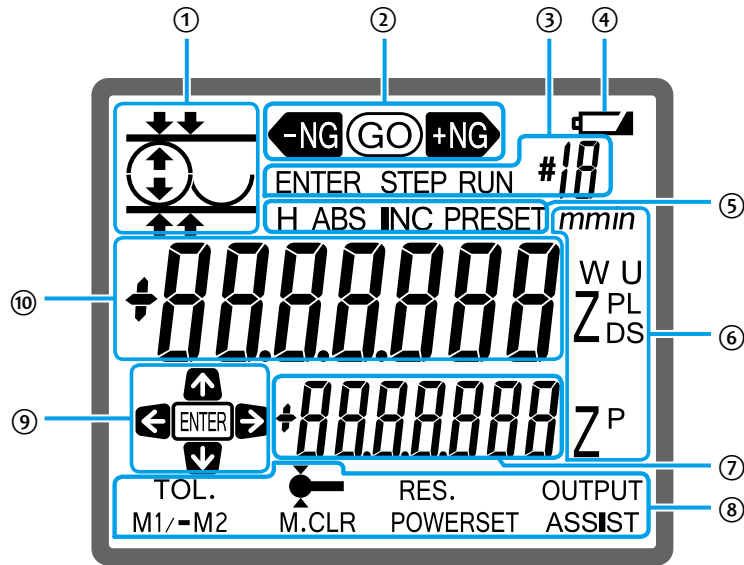

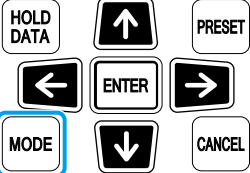
Number	Functions
①	Displays icons which represent measurement operations.
②	Indicates the result of the tolerance judgment. For details, see "3.2 Judging the Tolerance" on page 40.
③	Displayed when registering measurement steps or executing steps that have been registered. For details, see "3.4 Registering the Order of Measurements" on page 45.
④	Displayed when the batteries are depleted. Replace the batteries or use the AC adapter (optional accessory).
⑤	Displayed during the following operations. <ul style="list-style-type: none"> • [H]: When a measurement value is being held in the display. • [ABS]/[INC]: When switching between the ABS measurement system and the INC measurement system. • [PRESET]: When setting a value for the origin.
⑥	The meanings of the following letters, which are displayed during measuring, are explained below. <ul style="list-style-type: none"> • [Z^P]: The difference between two measurement values. • [U]/[L]: Upper/Lower tolerances • [Z_D]: Diameter • [Z^L]/[Z_S]/[W]: Maximum/Minimum/Displacement • [mm]: Millimeters (unit) • [in]: Inches (unit)
⑦	Displays the difference between two measurement values. For details, see "3.1 Calculating the Difference between Two Measurement Values" on page 33.
⑧	Displays the available settings when the [MODE] key is pressed. 
⑨	Indicates the available keys for an operation.
⑩	Displays the counted values or measurement values (results). For details, see "2 Basic Measuring Methods" on page 11.

1.3 Basic Operations

This section explains how to turn the power on and off, as well as how to move the main unit and the probe unit.

1.3.1 Turning the Power On and Off

A video about turning the power on and off can be viewed.



■ Turning the power on

Press [Power button] on the upper right of the LCD to turn on the power.





■ Turning the power off

Press [Power button] on the upper right of the LCD while the power is on to turn off the power.



1.3.2 Moving the Main Unit

	Do not move the main unit by grabbing parts other than the base or carrier grip. Doing so can negatively affect measurement accuracy and the product itself.
	Clean the surface plate in advance. Sliding performance may deteriorate and cause measurement errors.

■ Models without the air-float function (QMH-350AX, QMX-600AX, QMH-14"AX, QMH-24"AX)

When moving the main unit on the surface plate, grab the base with your right hand and the carrier grip with your left hand.

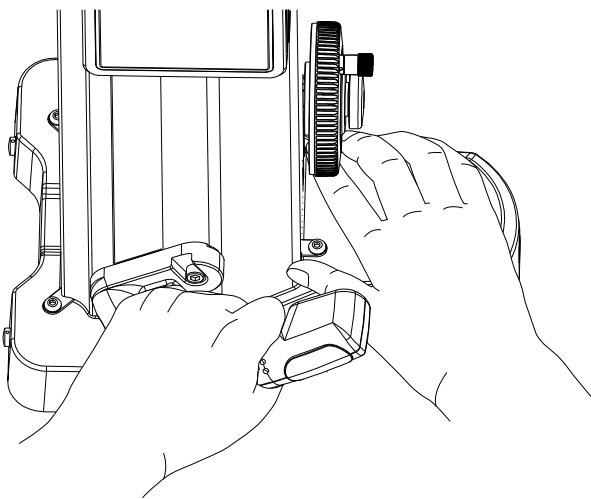

A video about moving the main unit can be viewed.



■ Models with the air-float function (QMH-350BX, QMX-600BX, QMH-14"BX, QMH-24"BX)

When moving the main unit on the surface plate, grab the base with your right hand and the carrier grip with your left hand.

Pressing the air-float switch on the tip of the carrier grip supplies air to raise the main unit, allowing you to move it smoothly above the surface plate. However, do not execute a measurement while the air-float function is active because a measurement error may occur.

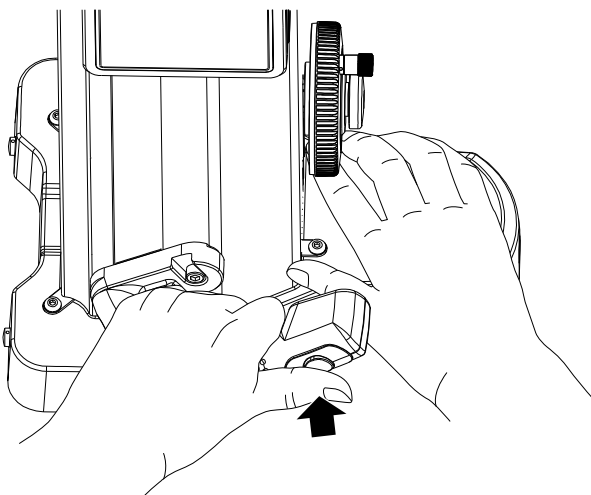

A video about moving the main unit can be viewed.



Tips

- Use a surface plate of Class JIS1 or higher. If the surface plate is scratched or uneven, the specified performance may not be achieved.
- Use a surface plate with high rigidity. If the surface plate warps under the weight of the product, the product cannot be raised.

● If the air-float function does not work

If the following icon is displayed on the LCD, the batteries are depleted, and the air-float function cannot be used. Replace the batteries with new ones.

Tips

If the batteries deplete quickly, use an AC adapter (optional accessory).

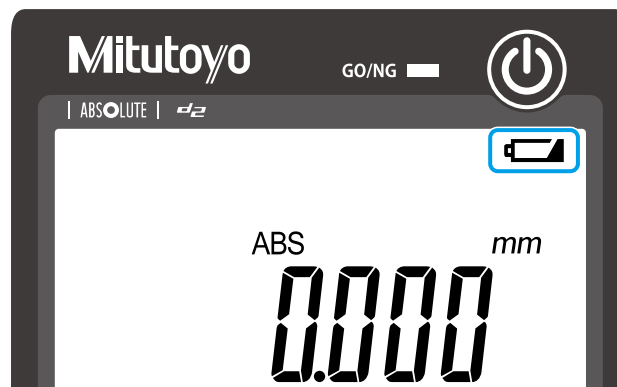

● Adjusting the amount of air-float flow

Turn the float amount adjustment screw with a flathead screwdriver to adjust the airflow. Turning it clockwise increases the airflow, and turning it counterclockwise decreases the airflow. Make adjustments according to the installation location.

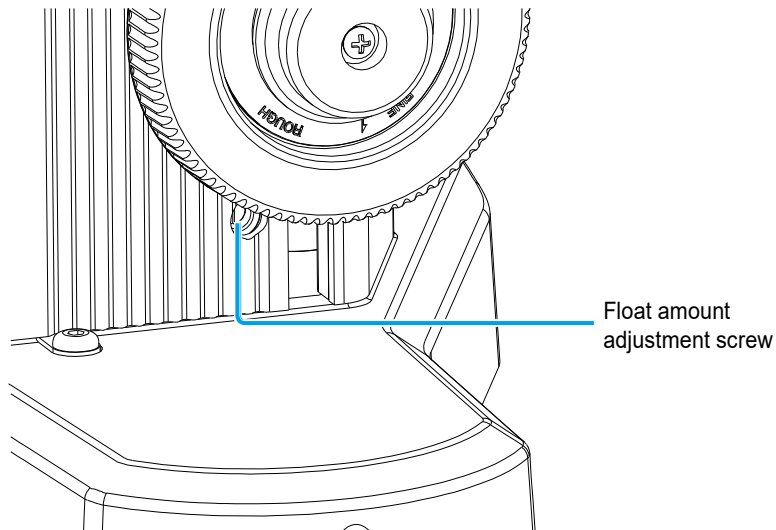

The airflow has been optimized before shipment. We recommend using the default settings as much as possible.

Tips

- Due to the characteristics of the air-float mechanism, an increase in airflow may cause the main unit to vibrate. In this case, reduce the airflow.
- If you have adjusted the airflow, make sure that the friction between the surface plate and the base is reduced before use.

1.3.3 Moving the Probe Unit

The probe unit is moved by operating the probe unit up/down wheel or the probe fine adjustment knob.

NOTICE



In order to prevent a reduction in the product's performance, do not move the probe unit by grabbing it.



Slowly turn the probe unit up/down wheel to prevent malfunction or damage.

● Quickly moving the probe unit (coarse movement)

Loosen the clamp screw (①), and turn the probe unit up/down wheel. Turning it clockwise (②) will raise the probe unit, and turning it counterclockwise (③) will lower the probe unit.

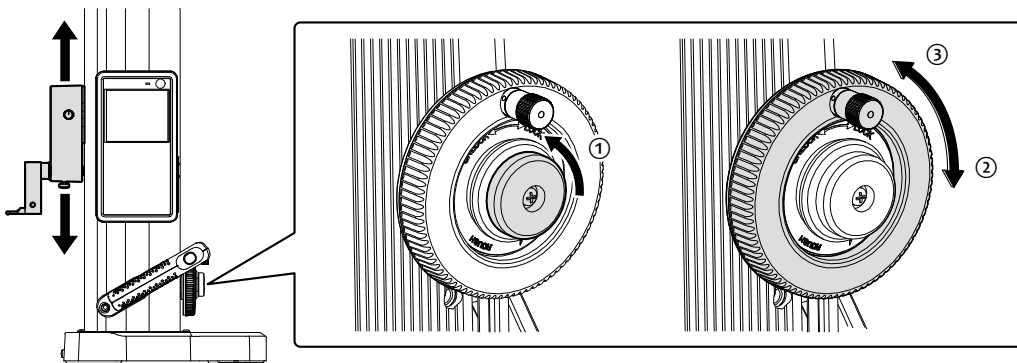

Tips

When moving the probe unit long distances, turn the probe unit up/down wheel while grabbing the probe fine adjustment knob (while pushed in).

● Slowly moving the probe unit (fine movement)

Loosen the clamp screw (①), and pull out and turn the probe fine adjustment knob (②). Turning it clockwise (③) will raise the probe unit, and turning it counterclockwise (④) will lower the probe unit.

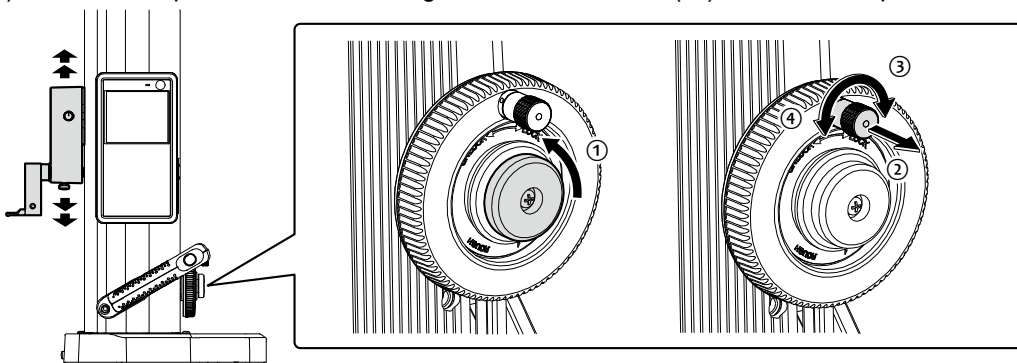

Tips

If the counter value displayed on the LCD remains the same even when the probe unit is moved up or down, press [HOLD DATA]. If this does not release the hold, follow the steps in [HOLD DATA] "When the counter value is held, and the measurement cannot be made" on page 58 to release the hold.

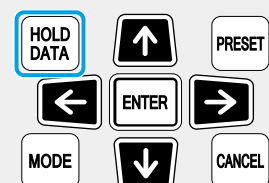





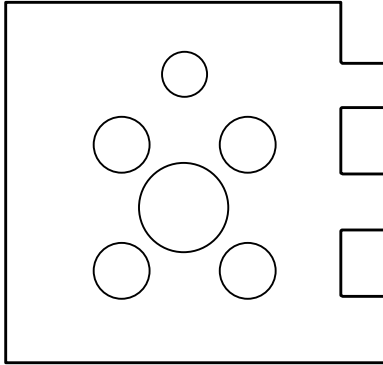



















2 Basic Measuring Methods

Using the following workpiece as an example, measurement preparations and the height, width, inside diameter, outside diameter, and plane displacement measuring methods will be explained.



Tips

Videos about measurement preparations and measurement methods can be viewed from the following QR codes or with [▶].

2.1 Preparing Measurements	Basic Measuring Methods	
2.1.1 Setting the Origin and the Reference <ul style="list-style-type: none"> • Setting the surface plate as the origin 	2.2 Measuring the Height	2.4 Measuring the Inside Diameter (Manual Termination)
page 12  	page 21  	page 26  
<ul style="list-style-type: none"> • Setting a position other than the surface plate as the origin 	2.3 Measuring Steps and Width (Step Measurements)	2.5 Measuring the Outside Diameter (Automatic Termination)
page 14  	page 22  	page 27  
<ul style="list-style-type: none"> ■ Setting the reference (INC measurement system) 	2.3 Measuring Steps and Width (Width Measurements)	2.5 Measuring the Outside Diameter (Manual Termination)
page 16  	page 22  	page 29  
2.1.2 Setting the Diameter of the Ball	2.4 Measuring the Inside Diameter (Automatic Termination)	2.6 Measuring the Plane Displacement (Plane Scanning Measurement)
page 18  	page 24  	page 30  

2.1 Preparing Measurements

Perform "Origin and reference setup" and "Probe diameter setup" before measuring.

2.1.1 Setting the Origin and the Reference

Set the origin or the reference for measuring height. The length from this position will be measured as the height. This product supports the ABS measurement system and the INC measurement system. Use the method that matches your application.

- **ABS measurement system (absolute value measurements)**

The height relative to the set origin is directly displayed.

For details about setting the origin, see  "■ Setting the origin (ABS measurement system)" on page 13.

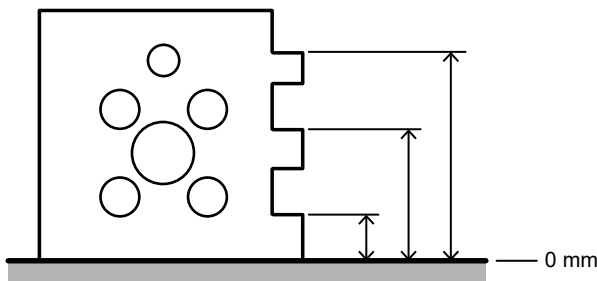

Example: The surface plate is set as the origin at 0 mm.

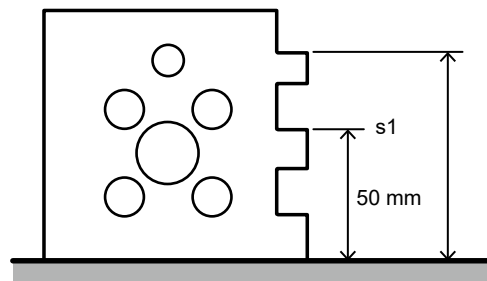

Example: Surface s1 is set as the origin at 50 mm.

- **INC measurement system (comparative measurements)**

The height relative to the set reference (0 mm) is displayed.

For details about setting the reference, see  "■ Setting the reference (INC measurement system)" on page 16.

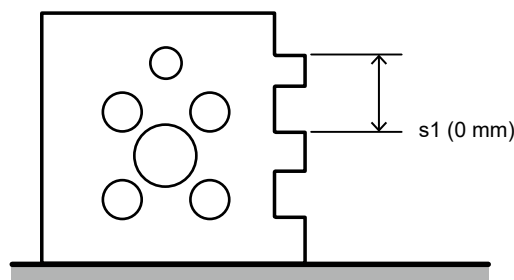

Example: Surface s1 is set as the reference (0 mm).

Tips

- When the power supply to the product is terminated by removing the batteries or unplugging the AC adapter (optional accessory), the set origin or reference will be erased. In this case, it must be set again.
- If the workpiece is large, and it is necessary to move the main unit, grab the base with your right hand and the carrier grip with your left hand to move it.

■ Setting the origin (ABS measurement system)

- Setting the surface plate as the origin

A video about the setup can be viewed.



1 Press [PRESET].

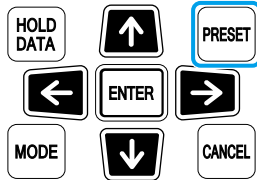

» The preset value from the previous occasion is displayed (initial value: +000.000).

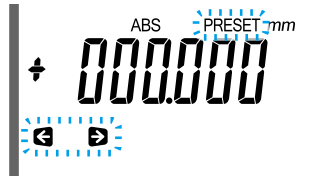

2 Check that [+000.000] is displayed on the LCD.

If a different value is displayed, set it to [+000.000]. For details about configuring the settings, see "● Setting a position other than the surface plate as the origin" on page 14.

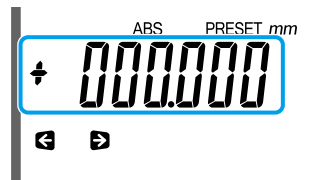

3 Set the origin.

- 1 Loosen the clamp knob.
- 2 Loosen the clamp screw.
- 3 Turn the probe unit up/down wheel, and slowly bring the stylus into contact with the surface plate until there is a "beep" sound.

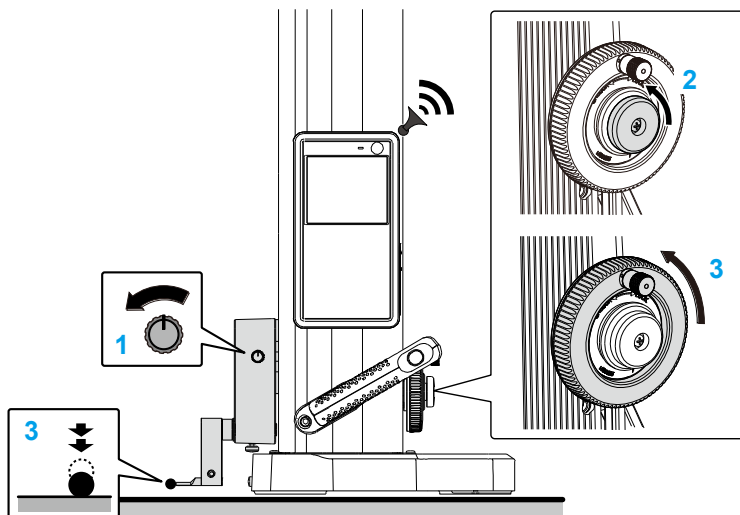

» The origin will be set, and the height relative to the set origin will be displayed in the top row of the display.



4 Confirm the set origin.

- 1 Slowly move the stylus away from the surface plate, and bring them into contact again by turning the probe unit up/down wheel until a "beep" sound is made.
- 2 Check that [0.000] is displayed on the LCD (the origin setup is complete).

Tips

If the origin is significantly different from [0.000], perform steps **1** through **4** again.

2 Basic Measuring Methods

- Setting a position other than the surface plate as the origin

A video about the setup can be viewed.



As an example, the procedure for using a 25 mm gauge block is explained below (setting value: +025.000).

Tips

Height measurements near 25 mm are more accurate when compared to when the surface plate is set as the origin.

1 Press [PRESET].

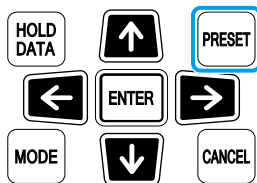

- » The preset value from the previous occasion is displayed (initial value: +000.000).

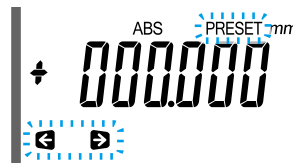

2 Press [→] to make [+] blink.

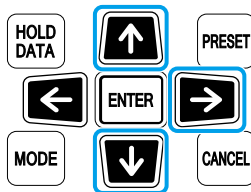

- » [+] will blink.

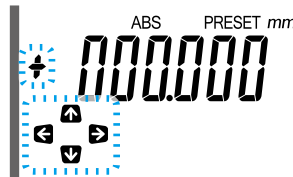

If [-] is displayed, press [↑] or [↓] to change the display to [+].

3 Repeatedly press [→] until the value in the tens place flashes.

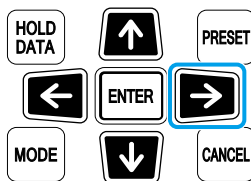

- » The value in the tens place will flash.

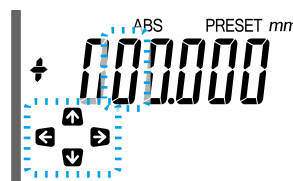

4 Press [↑] or [↓] to display [2].

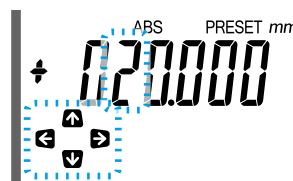
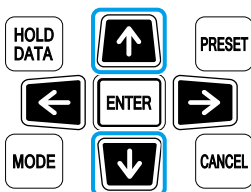

5 Display [5] in the ones place using the same procedure described in steps **3** and **4**.

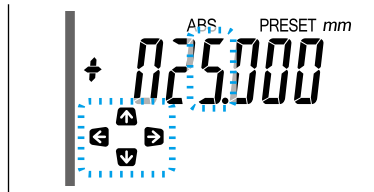

6 Set the origin.

- 1** Loosen the clamp knob.
- 2** Loosen the clamp screw.
- 3** Turn the probe unit up/down wheel, and slowly bring the stylus into contact with the top surface of the gauge block until there is a "beep" sound.

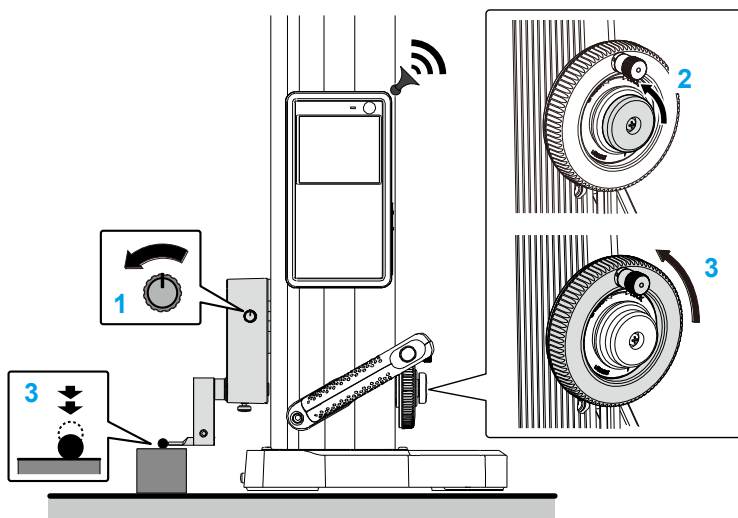

» The origin will be set, and the height relative to the set origin will be displayed in the top row of the display.



Tips

For measurements using a lever-type dial gauge (optional accessory) or dial gauge (optional accessory), bring the stylus into contact with the gauge block without loosening the clamp knob, and after aligning the hand to the zero point, press [ENTER] to finish the setup.

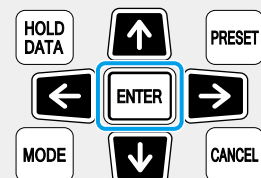

7 Confirm the set origin.

- 1** Slowly move the stylus away from the top surface of the gauge block, and bring them into contact again by turning the probe unit up/down wheel until a "beep" sound is made.
- 2** Check that [25.000] is displayed on the LCD (the origin setup is complete).

Tips

If the origin is significantly different from [25.000], perform steps **1** through **7** again.

■ Setting the reference (INC measurement system)

A video about the setup can be viewed.



1 Press [ZERO/ABS].



» Switches to the INC measurement system (this also sets the display to zero).

INC mm
0.0000

2 Set the reference.

- 1 Loosen the clamp knob.
- 2 Loosen the clamp screw.
- 3 Turn the probe unit up/down wheel, and lower the stylus to a position near the surface of the reference.
- 4 Adjust the position of the workpiece.

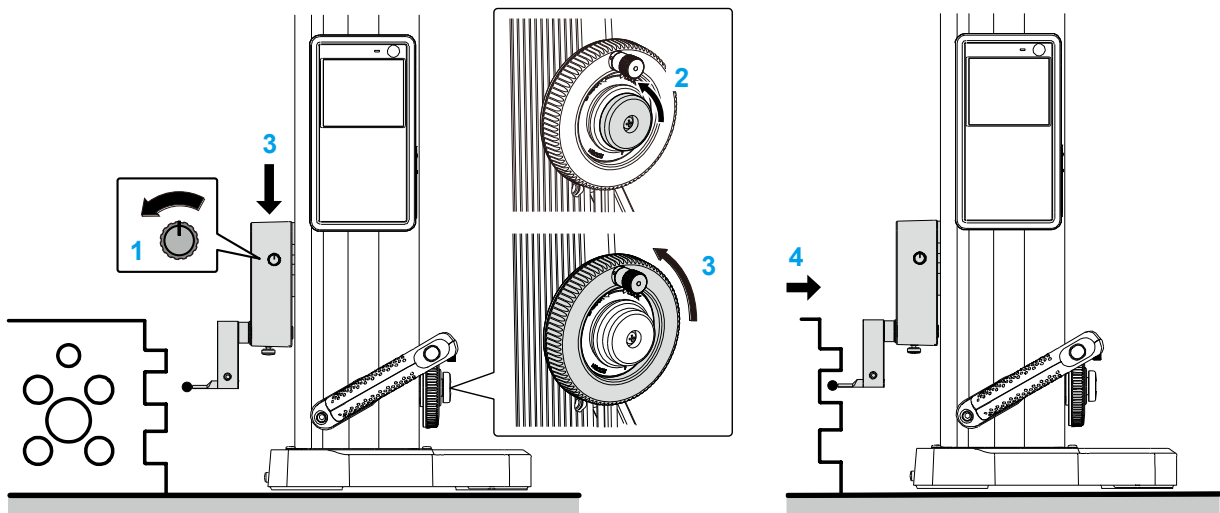

- 5 Turn the probe unit up/down wheel, and slowly bring the stylus into contact with the reference until there is a "beep" sound.

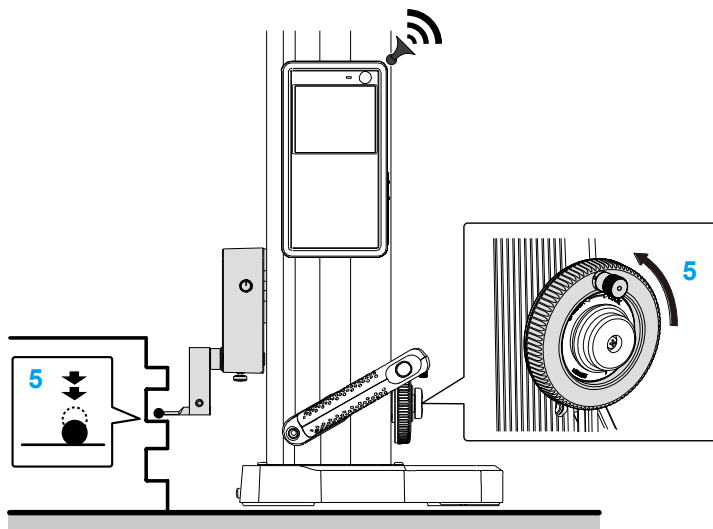

» The reference will be set, and the height relative to the set reference will be displayed in the top row of the display.

INC mm
0.321
0.0000 Z^P

3 Confirm the set reference.

- 1 Slowly move the stylus away from the reference, and bring them into contact again by turning the probe unit up/down wheel until a "beep" sound is made.
- 2 Check that [0.000] is displayed in the bottom row of the LCD (the reference setup is complete).

Tips

If the reference is significantly different from [0.000], perform steps **1** through **3** again.

2.1.2 Setting the Diameter of the Ball on the Tip of the Stylus

A video about the setup can be viewed.



The origin or the reference is set when contact is made with the bottom surface of the ball on the tip of the stylus. The value displayed is the height of the position of the bottom surface of the ball (refer to left diagram below).

Therefore, for measuring a height of the top surface (bottom left diagram), the correct value is displayed, but for measuring a height of the bottom surface where contact is made with the top of the ball (bottom right diagram), the diameter of the ball must be added.

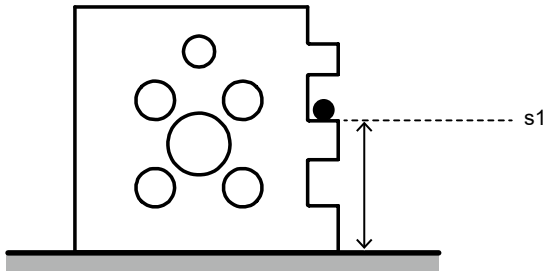

The height of the measuring surface = the height of the bottom of the ball

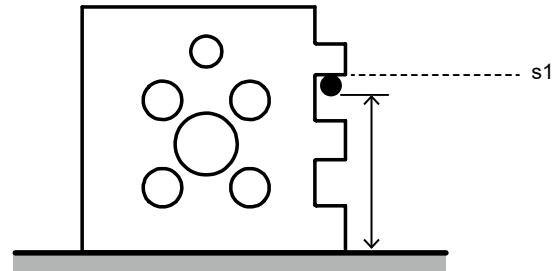

The height of the measuring surface = the height of the bottom of the ball + the diameter of the ball

By measuring and setting the diameter of the ball on the tip of the stylus with the supplied ball diameter calibration block in advance, the bottom surface measurement will display a height value that automatically accounts for the diameter of the ball.



- This procedure is necessary if you are using the product for the first time or if you are replacing the stylus.
- To perform the setup using gauge blocks, use at least 20 mm of gauge blocks that have been wrung together. (Bottom right diagram)

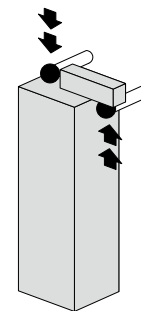

Ball diameter calibration block
Examples of use

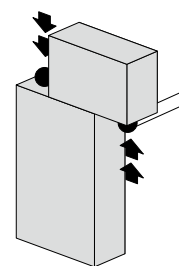

Gauge block
Examples of use

This section explains how to calculate and set the diameter of the ball on the tip of the stylus by measuring two surfaces of the ball diameter calibration block that are the same height.

1 Press [MODE].

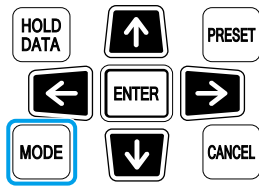

» Characters and icons will be displayed in the bottom row of the LCD.

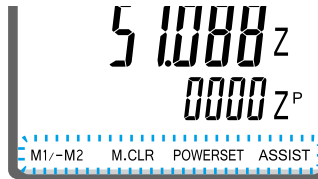

2 Press [Outside diameter measurement] and select the icon for [Probe settings].

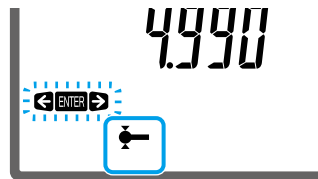

3 Press [ENTER].

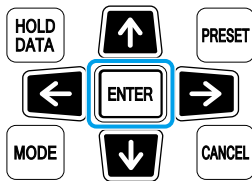

» An icon will be displayed in the upper left of the LCD ([↓] will blink).

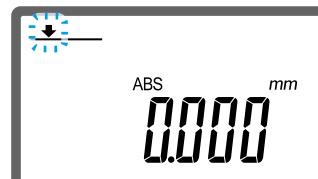

4 Measure the top surface of the ball diameter calibration block.

- 1 Install the ball diameter calibration block.
- 2 Loosen the clamp knob.
- 3 Loosen the clamp screw.
- 4 Turn the probe unit up/down wheel, and slowly bring the stylus into contact with the top surface of the ball diameter calibration block until there is a "beep" sound.

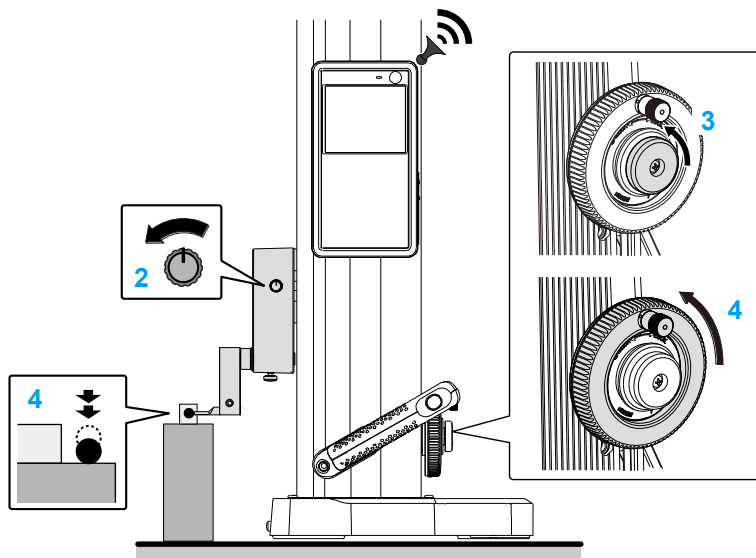

» An icon will be displayed in the upper left of the LCD ([↑] will blink).



5 Measure the bottom surface of the ball diameter calibration block.

- 1 Move the ball diameter calibration block (or main unit), and move the stylus to the following position near the ball diameter calibration block.
- 2 Turn the probe unit up/down wheel, and slowly bring the stylus into contact with the bottom surface of the ball diameter calibration block until there is a "beep" sound.

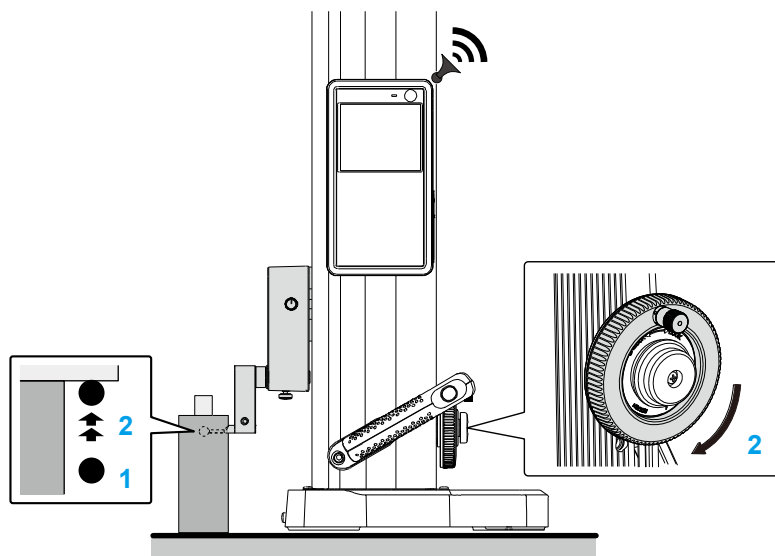

» The probe diameter calibration is complete.



Tips

- The dimensions of the ball diameter and the calibrated value of the probe diameter may not match exactly due to bending of the stylus.
- The moment the beep sounds, the displayed value may appear to jump. The calculation of the ball's diameter will then be displayed.

6 Press [ENTER].

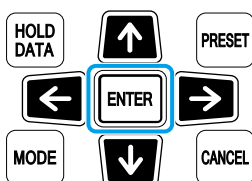

» The ball diameter setup is complete.



2.2 Measuring the Height

A video about measuring the height can be viewed.



Measure the height. Height measurements are divided into "top surface height measurements", where the top surface of the workpiece is brought into contact with the stylus, and "bottom surface height measurements", where the bottom surface is brought into contact with the stylus.

This section explains both measurement procedures using the surface plate as the origin (ABS measurement system).

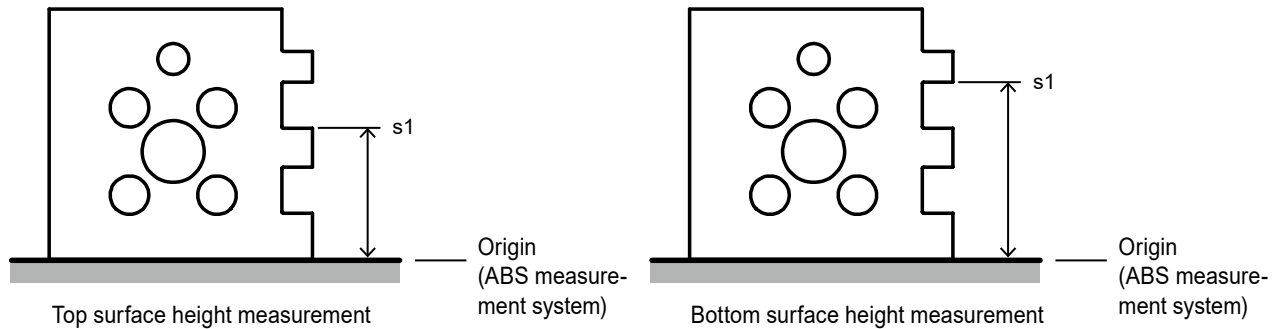

1 Set the surface plate as the origin (ABS measurement system).

For details about the setup, see  "2.1.1 Setting the Origin and the Reference" on page 12.

2 Turn the probe unit up/down wheel, and slowly bring the stylus into contact with surface s1 until there is a "beep" sound (keep the stylus in contact with the surface).

• For top surface height measurements

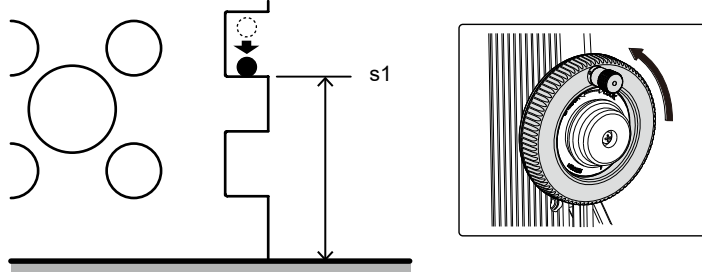

» When the measurement is complete, [H] and the measurement value are displayed on the LCD.

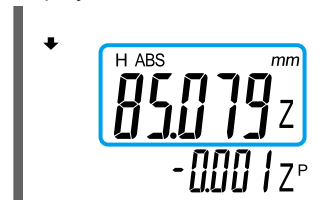

• For bottom surface height measurements

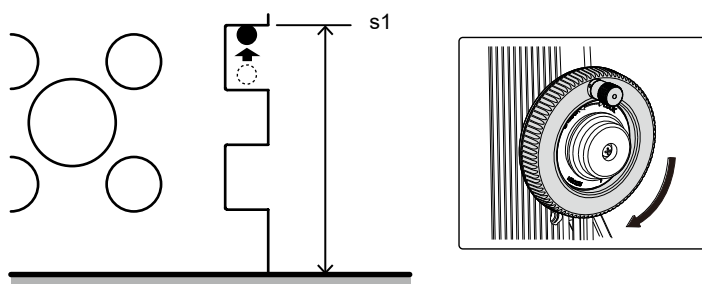

» When the measurement is complete, [H] and the measurement value are displayed on the LCD.

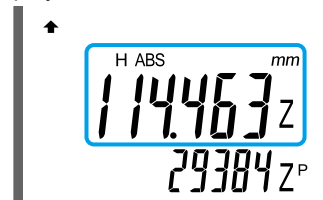

It will be automatically output at the same time to the connected external device.

3 Press [HOLD DATA].

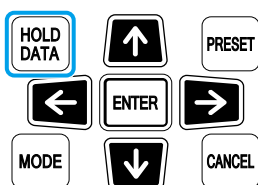

» The displayed measurement value is held. (Press [HOLD DATA] again to release the hold.)

2.3 Measuring Steps and Width

A video about step measurements can be viewed.



A video about measuring the width can be viewed.



Measure steps or width.

This section explains the measurement procedure using surface s1 as the reference (INC measurement system).

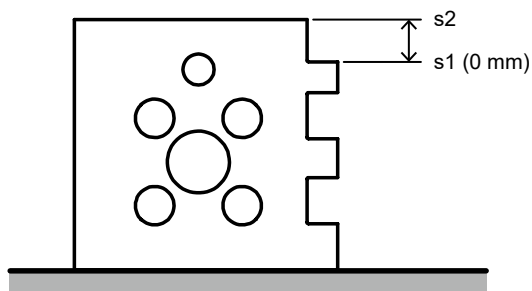

Step measurement

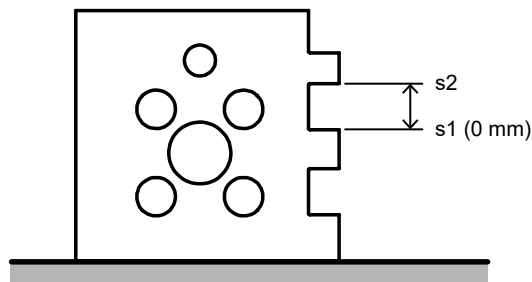

Groove width measurement

1 Set surface s1 as the reference (INC measurement system).

For details about the setup, see "2.1.1 Setting the Origin and the Reference" on page 12.

2 Turn the probe unit up/down wheel, and slowly bring the stylus into contact with surface s1 until there is a "beep" sound.

- For step measurements

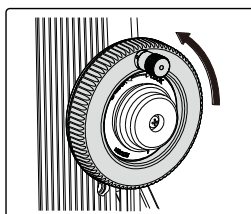
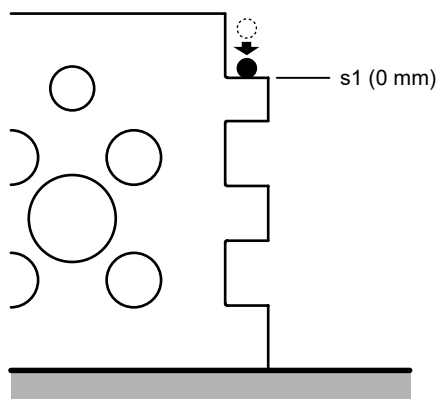

» [0.000] will be displayed on the LCD.

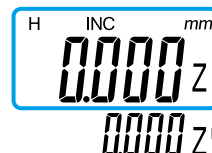

- For groove width measurements

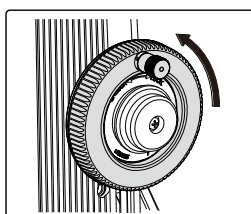
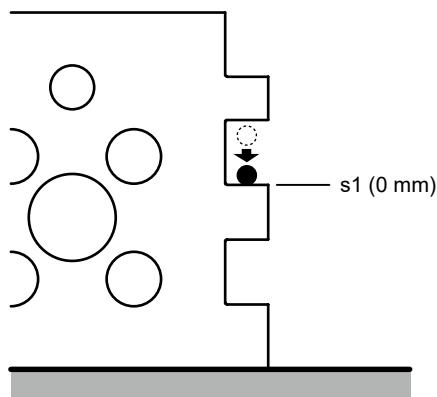

» [0.000] will be displayed on the LCD.

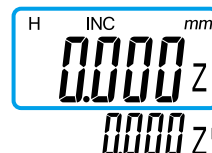

3 Turn the probe unit up/down wheel, and slowly bring the stylus into contact with surface s2 until there is a "beep" sound (keep the stylus in contact with the surface).

- For step measurements

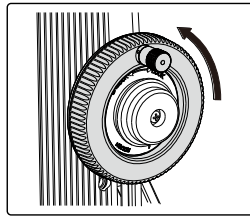
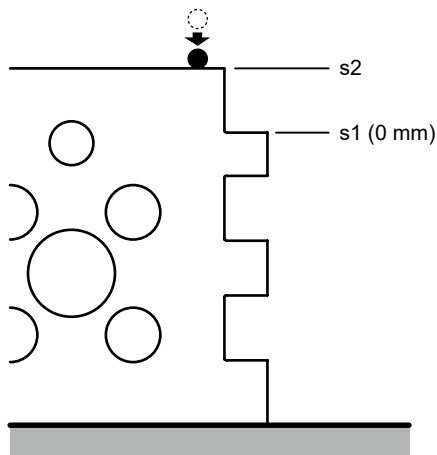

» When the measurement is complete, [H] and the measurement value are displayed on the LCD.

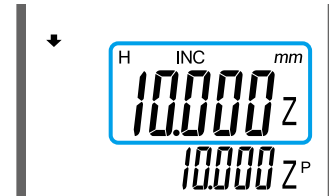

It will be automatically output at the same time to the connected external device.

- For groove width measurements

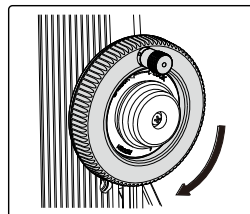
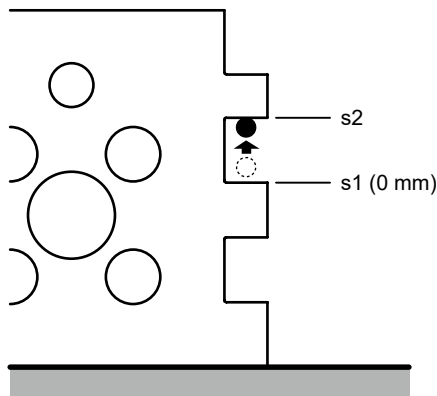

» When the measurement is complete, [H] and the measurement value are displayed on the LCD.

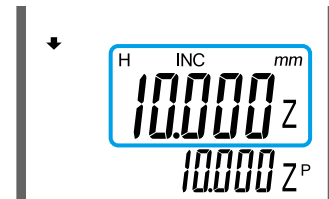

It will be automatically output at the same time to the connected external device.

4 Press [HOLD DATA].

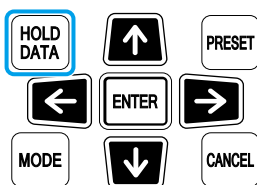

» The displayed measurement value is held. (Press [HOLD DATA] again to release the hold.)

2.4 Measuring the Inside Diameter

A video about inside diameter measurements can be viewed.



Measure the diameter (inside diameter) of a hole. By scanning the upper and lower surfaces of a hole with the stylus, the peak points can be detected. The diameter is calculated from the difference. The diameter of a semicircle where part of the top or bottom of the hole is missing cannot be obtained. This section explains the measurement procedure using the surface plate as the origin (ABS measurement system).

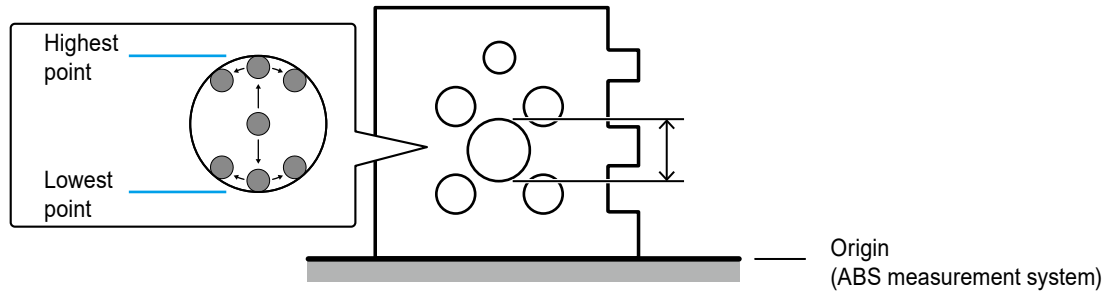

1 Check the setting for the termination method of the scanning measurement (automatic termination or manual termination).

For details about the setup method, see  "3.3 Setting the Termination Method of Scanning Measurements" on page 44.

Tips

The operation in step **4** differs for "automatic termination" and "manual termination".

2 Set the surface plate as the origin (ABS measurement system).

For details about the setup, see  "2.1.1 Setting the Origin and the Reference" on page 12.

3 Press [Inside diameter measurement].



» An icon will be displayed in the upper left of the LCD.



4 Detect the lowest point of the hole.



- If [Auto] (automatic termination) is set, ensure that the stylus is positioned to pass through the lowest point of the hole. When the stylus is raised about 0.5 mm from the lowest point of the hole, a beep sound will be made, and the peak-point detection will automatically terminate.
- Bring the stylus into contact within 0.5 mm of the lowest point. Measuring with a wider range may increase measurement errors.

1 Turn the probe unit up/down wheel, and slowly bring the stylus into contact near the center of the bottom surface of the hole until there is a "beep" sound (keep the stylus in contact with the surface).

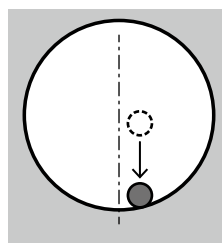

» [0.000] will be displayed on the LCD.

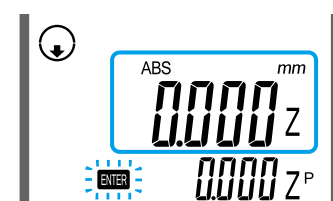

- 2 While keeping the probe unit up/down wheel stationary, move the workpiece or the main unit so the stylus moves and passes through the lowest point (there will be a beep sound, and the lowest point will be automatically detected).

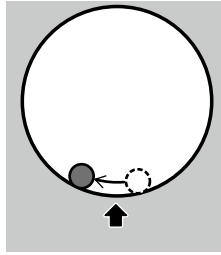

- » The measurement of the lowest point is complete, and an icon will be displayed on the upper left of the LCD.



• For manual termination

- 1 While keeping the probe unit up/down wheel stationary, move the workpiece or the main unit so the stylus moves left/right and passes through the lowest point.

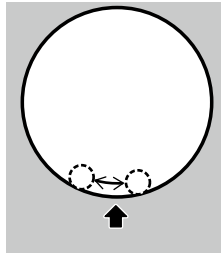

- » The counter value will change according to the movements, and the value will be held when the lowest point is detected.

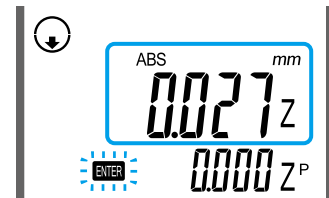

- 2 Press [ENTER].

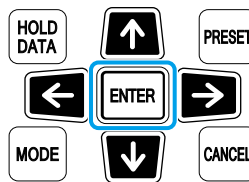

- » The measurement of the lowest point is complete, and an icon will be displayed on the upper left of the LCD.

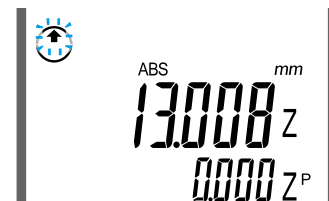

Tips

If the probe unit up/down wheel is difficult to secure, tighten the clamp screw.

5 Detect the highest point of the hole.



- If [Auto] (automatic termination) is set, ensure that the stylus is positioned to pass through the highest point of the hole. When the stylus is lowered about 0.5 mm from the highest point of the hole, a beep sound will be made, and the peak-point detection will automatically terminate.
- Bring the stylus into contact within 0.5 mm of the highest point. Measuring with a wider range may increase measurement errors.

- 1 Turn the probe unit up/down wheel, and slowly bring the stylus into contact near the center of the top surface of the hole until there is a "beep" sound (keep the stylus in contact with the surface).

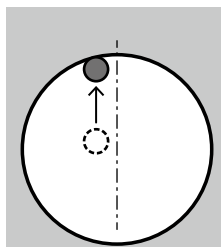

- » The height relative to the origin will be displayed on the LCD.

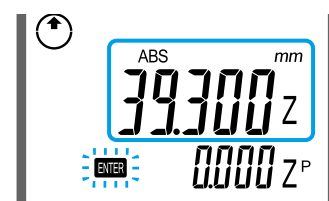

2 Basic Measuring Methods

- 2 While keeping the probe unit up/down wheel stationary, move the workpiece or the main unit so the stylus moves and passes through the highest point (there will be a beep sound, and the highest point will be automatically detected).

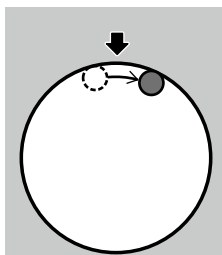

- » The measurement of the highest point is complete, and the measurement value (diameter) will be displayed.

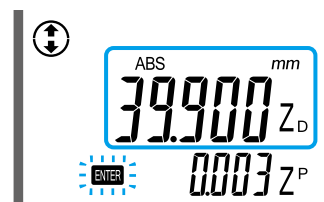

It will be automatically output at the same time to the connected external device.

• For manual termination

- 1 While keeping the probe unit up/down wheel stationary, move the workpiece or the main unit so the stylus moves left/right and passes through the highest point.

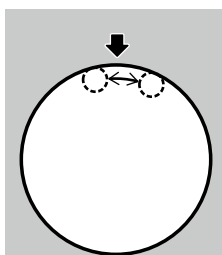

- » The counter value will change according to the movements, and the value will be held when the highest point is detected.

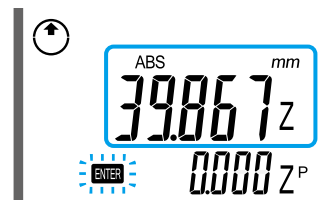

- 2 Press [ENTER].

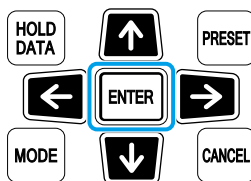

- » The measurement of the highest point is complete, and the measurement value (diameter) will be displayed.

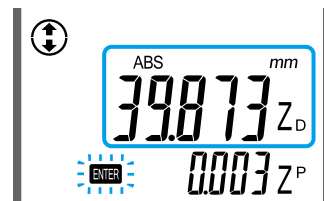

It will be automatically output at the same time to the connected external device.

Tips

- If the probe unit up/down wheel is difficult to secure, tighten the clamp screw.
- A video about the inside diameter measurement (manual termination) can be viewed from [here](#).



- 6 To continue measuring another inside diameter, press [ENTER]; to finish measuring press [CANCEL].

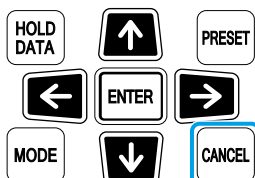
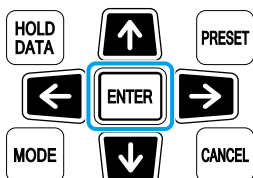

2.5 Measuring the Outside Diameter

A video about outside diameter measurements can be viewed.



Measure the diameter (outside diameter) of a cylinder. By scanning the upper and lower surfaces of a cylinder with the stylus, the peak points can be detected. The diameter is calculated from the difference. The diameter of a semicircle where part of the top or bottom of the hole is missing cannot be obtained. This section explains the measurement procedure using the surface plate as the origin (ABS measurement system) and using automatic termination.

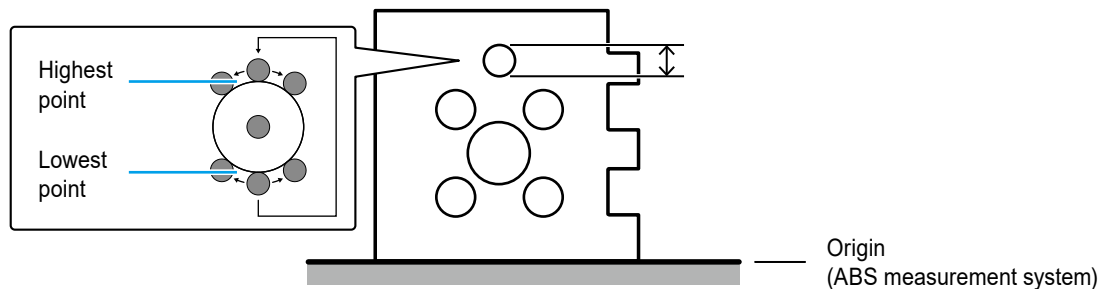

1 Check the setting for the termination method of the scanning measurement (automatic termination or manual termination).

For details about the setup method, see "3.3 Setting the Termination Method of Scanning Measurements" on page 44.

Tips

If the scanning measurement is set to be terminated manually, the procedures in step **4** are different.

2 Set the surface plate as the origin (ABS measurement system).

For details about the setup, see "2.1.1 Setting the Origin and the Reference" on page 12.

3 Press [Outside diameter measurement].



» An icon will be displayed in the upper left of the LCD.

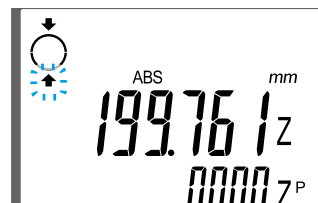

4 Detect the lowest point of the cylinder.



- If [Auto] (automatic termination) is set, ensure that the stylus is positioned to pass through the lowest point of the cylinder. When the stylus is raised about 0.5 mm from the lowest point of the cylinder, a beep sound will be made, and the peak-point detection will automatically terminate.
- Bring the stylus into contact within 0.5 mm of the lowest point. Measuring with a wider range may increase measurement errors.

- 1 Turn the probe unit up/down wheel, and slowly bring the stylus into contact near the center of the bottom surface of the cylinder until there is a "beep" sound (keep the stylus in contact with the surface).

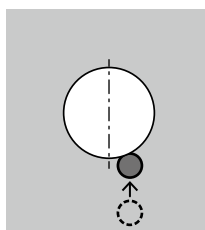

» [0.000] will be displayed on the LCD.

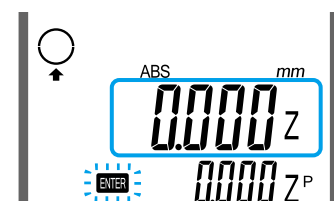

2 Basic Measuring Methods

- While keeping the probe unit up/down wheel stationary, move the workpiece or the main unit so the stylus moves and passes through the lowest point (there will be a beep sound, and the lowest point will be automatically detected).

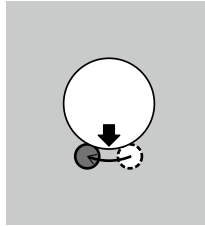

- » The measurement of the lowest point is complete, and an icon will be displayed on the upper left of the LCD.

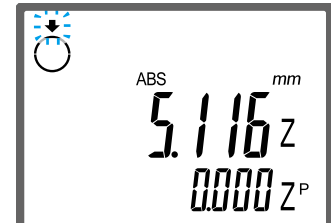

• For manual termination

- While keeping the probe unit up/down wheel stationary, move the workpiece or the main unit so the stylus moves left/right and passes through the highest point.

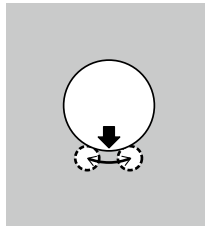

- » The counter value will change according to the movements, and the value will be held when the lowest point is detected.

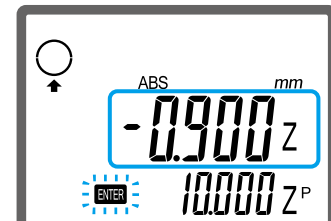

- Press [ENTER].

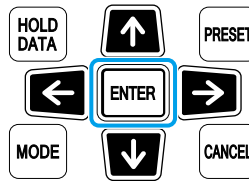

- » The measurement of the lowest point is complete, and an icon will be displayed on the upper left of the LCD.



Tips

If the probe unit up/down wheel is difficult to secure, tighten the clamp screw.

5 Detect the highest point of the cylinder.



- If [Auto] (automatic termination) is set, ensure that the stylus is positioned to pass through the highest point of the cylinder. When the stylus is lowered about 0.5 mm from the highest point of the cylinder, a beep sound will be made, and the peak-point detection will automatically terminate.
- Bring the stylus into contact within 0.5 mm of the highest point. Measuring with a wider range may increase measurement errors.

- Turn the probe unit up/down wheel, and slowly bring the stylus into contact near the center of the top surface of the cylinder until there is a "beep" sound (keep the stylus in contact with the surface).

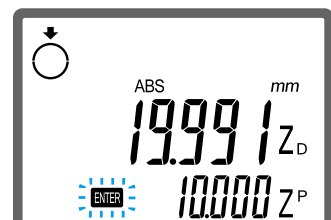
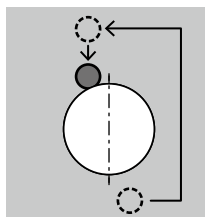

- 2 While keeping the probe unit up/down wheel stationary, move the workpiece or the main unit so the stylus moves and passes through the highest point (there will be a beep sound, and the highest point will be automatically detected).

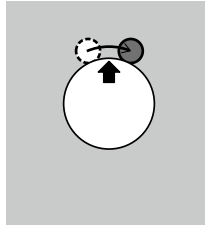

- » The measurement of the highest point is complete, and the measurement value (diameter) will be displayed.

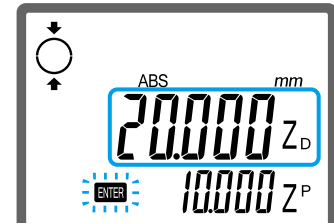

It will be automatically output at the same time to the connected external device.

• For manual termination

- 1 While keeping the probe unit up/down wheel stationary, move the workpiece or the main unit so the stylus moves left/right and passes through the highest point.

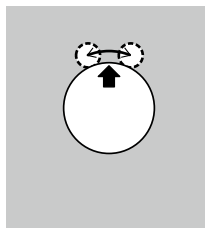

- » The counter value will change according to the movements, and the value will be held when the highest point is detected.

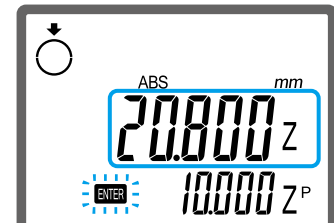

- 2 Press [ENTER].

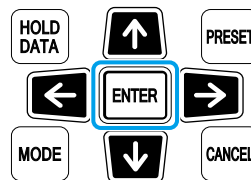

- » The measurement of the highest point is complete, and the measurement value (diameter) will be displayed.

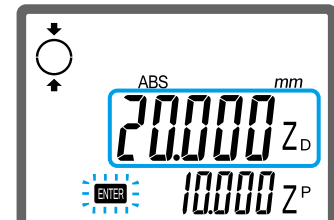

It will be automatically output at the same time to the connected external device.

Tips

- If the probe unit up/down wheel is difficult to secure, tighten the clamp screw.
- A video about the outside diameter measurement (manual termination) can be viewed from here.



- 6 To continue measuring another outside diameter, press [ENTER]; to finish measuring press [CANCEL].

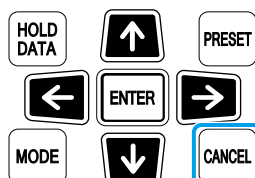
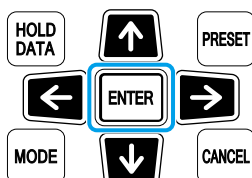

2.6 Measuring the Plane Displacement (Plane Scanning Measurement)

A video about plane scanning measurements can be viewed.



Measure the displacement value (maximum – minimum) of a flat surface. By scanning the surface of the workpiece with the stylus, the highest (maximum) and lowest (minimum) points can be detected. The displacement is calculated from the difference (maximum – minimum).

This section explains the procedure to measure displacement A using the surface plate as the origin (ABS measurement system).

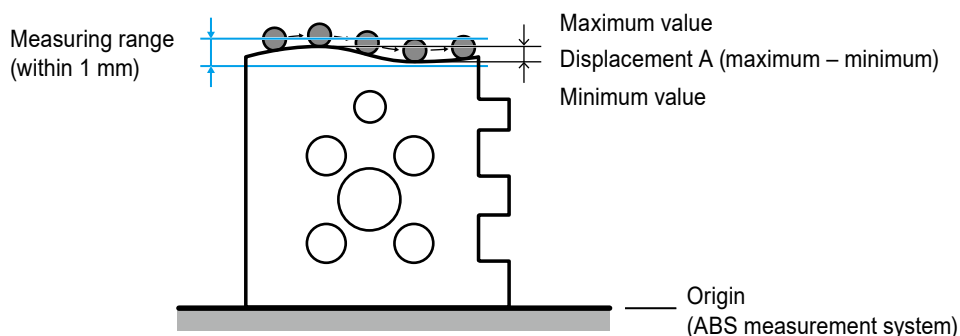

1 Press [Scanning measurement].



» An icon will be displayed in the upper left of the LCD.

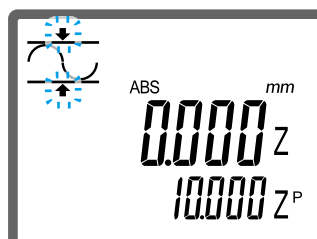

2 Begin measuring.

- 1 Loosen the clamp knob.
- 2 Loosen the clamp screw.

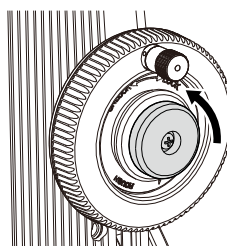

- 3 Turn the probe unit up/down wheel, and slowly bring the stylus into contact with the measuring surface until there is a "beep" sound (keep the stylus in contact with the surface).

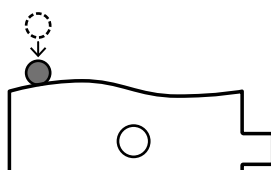

» [0.000] will be displayed on the LCD.

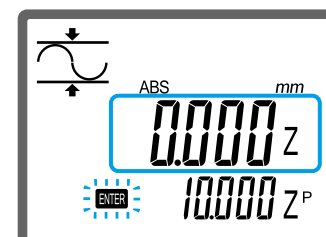

- 4 While keeping the probe unit up/down wheel stationary, move the workpiece or the main unit to scan the surface of the workpiece.

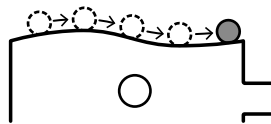

- » The counter value will change according to the scanning movement.

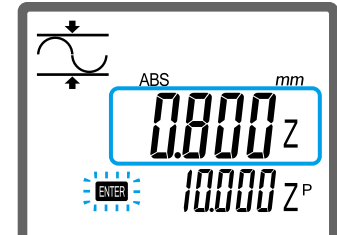

Tips

- When both the highest and lowest points are detected, the value that is displayed on the LCD will be held.
- If the probe unit up/down wheel is difficult to secure, tighten the clamp screw.

- 5 Press [ENTER].

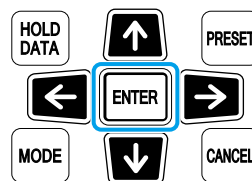

- » The scanning measurement is complete, and displacement A (1.000 mm) will be displayed.

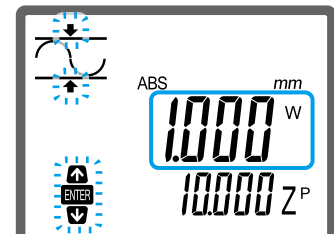

It will be automatically output at the same time to the connected external device.

- 3 Press [↑] or [↓] to check the measurement result.

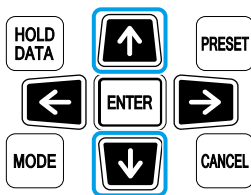

- » For each key press, the counter value will switch among [displacement (W)], [minimum (ZS)], and [maximum (ZL)].

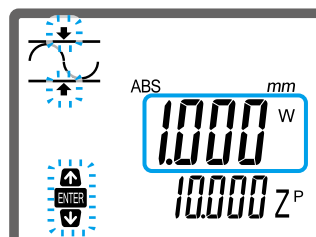

Tips

The difference between the median displacement value and the previous measurement value will be displayed in the bottom row of the LCD.

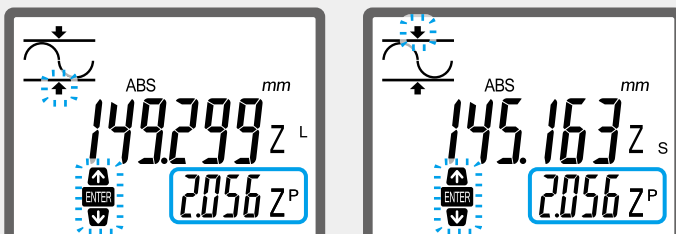

- 4** To continue using scanning measurements to measure another workpiece, press [ENTER]; to finish measuring press [CANCEL].

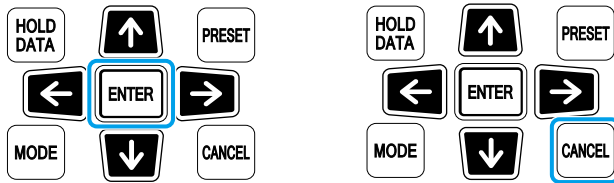

3 Specific Usage Applications

3.1 Calculating the Difference between Two Measurement Values

The result of the calculation of the difference (calculation result) between two measurement values is displayed in the bottom row of the LCD.

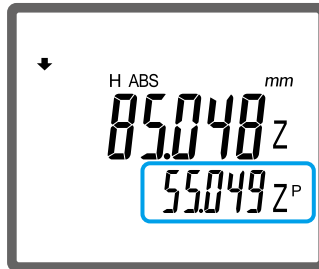

There are three different items for calculating the difference between two measurement values. Use the method that matches your application.

- Calculating the difference between the current and previous measurement values (regular condition)

In the regular condition, the difference between the current measurement value and the previous measurement value is displayed in the bottom row of the LCD.

For example, if the current measurement value is 45.000 mm and the previous measurement value is 25.000 mm, [20.000] will be displayed. The difference between the current measurement value and the previous measurement value can be checked by reading the value displayed in the bottom row. For details, see "3.1.1 Calculating the Difference between the Current and Previous Measurement Values" on page 34.

Tips

If inside diameter, outside diameter, or plane scanning measurements are made, the center value of the inside diameter, the center value of the outside diameter, or the median value for the displacement is used respectively for the calculation.

- Calculating the difference between the current measurement value and a set reference

When a reference is set, the difference between the current measurement value and the reference is displayed in the bottom row of the LCD.

For example, if the surface plate is set as the reference, and multiple circles are measured continuously, the height of the center of each circle relative to the surface plate will be displayed in the bottom row of the LCD.

For details, see "3.1.2 Calculating the Difference between the Current Measurement Value and a Set Reference" on page 35.

Tips

The measurement value varies according to the type of measurement.

- Inside diameter measurement: Center of the inside diameter
- Outside diameter measurement: Center of the outside diameter
- Plane scanning measurement: Median, minimum, or maximum value

3 Specific Usage Applications

- Calculating the difference between two measurement values stored in memory

The two measurement values are stored in the product's internal memory, and then the difference is calculated.

This is appropriate for calculating the difference between measurement values when the previous two methods cannot be used.

For details, see  "3.1.3 Calculating the Difference between Two Measurement Values Stored in Memory" on page 37.

3.1.1 Calculating the Difference between the Current and Previous Measurement Values

In the regular condition, the difference between the current measurement value and the previous measurement value is displayed in the bottom row of the LCD.

This section explains the procedure for calculating the difference between measurement values (s_2-s_1 , s_3-s_2) when the height is measured in the order of s_1 , s_2 , s_3 after the surface plate is set as the origin (ABS measurement system) as shown below.

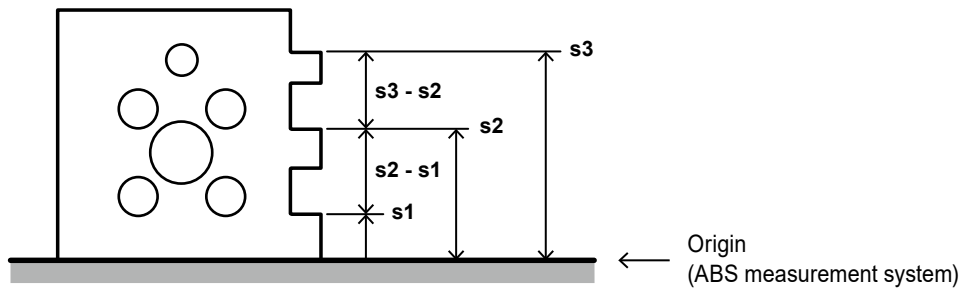

1 Set the surface plate as the origin (ABS measurement system).

For details about the setup, see  "• Setting the surface plate as the origin" on page 13.

2 Measure the height of s_1 .

For details about measuring height, see  "2.2 Measuring the Height" on page 21.

» The measurement value for s_1 is displayed.

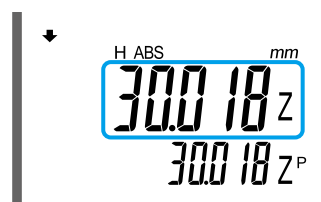

3 Measure the height of s_2 .

» The measurement value for s_2 is displayed in the top row, and the difference between s_2 and s_1 is displayed in the bottom row.



4 Measure the height of s3.

- » The measurement value for s3 is displayed in the top row, and the difference between s3 and s2 is displayed in the bottom row.

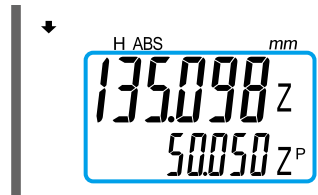

Tips

If inside diameter, outside diameter, or plane scanning measurements are made, the center value of the inside diameter, the center value of the outside diameter, or the median value for the displacement is used respectively for the calculation. For example, if the inside diameter is measured in the order of circle 1 and circle 2, the difference between the height of center circle 1 and center circle 2 will be displayed in the bottom row of the LCD.

3.1.2 Calculating the Difference between the Current Measurement Value and a Set Reference

When a reference is set, the difference between the current measurement value and the reference is displayed in the bottom row of the LCD.

This section explains the procedure for calculating the height of center cp1 of circle c1 and the height of center cp2 of circle c2 after the surface plate is set as the reference as shown below.

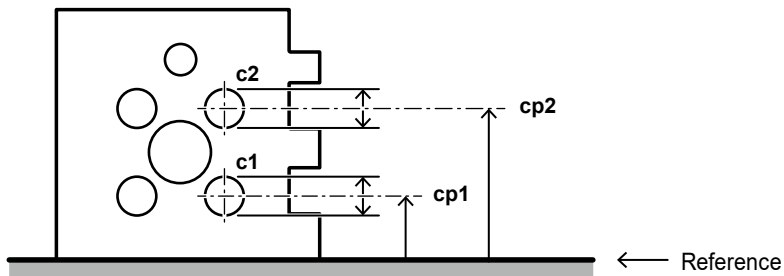

Tips

When the power supply to the product is terminated by removing the batteries or unplugging the AC adapter (optional accessory), the set reference will be erased.

1 Set the reference.

- 1 Perform procedures 1 through 3 in "■ Setting the origin (ABS measurement system)" on page 13 (keep the stylus in contact with the surface).

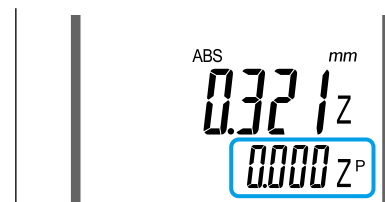

Tips

Measurement values for inside diameter measurements, outside diameter measurements, and plane scanning measurements can be obtained by performing the corresponding operation. For details, see "2.4 Measuring the Inside Diameter" on page 24, "2.5 Measuring the Outside Diameter" on page 27, and "2.6 Measuring the Plane Displacement (Plane Scanning Measurement)" on page 30.

3 Specific Usage Applications

- 2 While [0.000] is displayed, press and hold [→] until a beep sound is made.

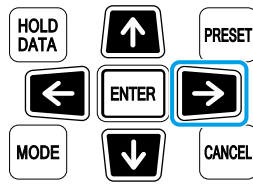

» The surface plate is set as the reference.

ABS mm
0.000 Z
0.000 Z^P

Tips

The measurement value and reference vary according to the type of measurement.

- Inside diameter measurement: Center of the inside diameter
- Outside diameter measurement: Center of the outside diameter
- Plane scanning measurement: Median, minimum, or maximum value

2 Measure the inside diameter of c1.

For details about measuring inside diameters, see "2.4 Measuring the Inside Diameter" on page 24.

» The inside diameter (measurement value) of c1 is displayed in the top row, and the height from the surface plate to the center of the inside diameter (difference in height with the set reference) is displayed in the bottom row.

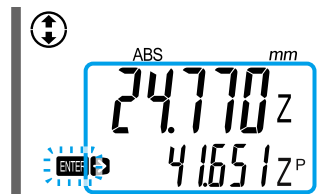

3 Measure the inside diameter of c2.

» The inside diameter (measurement value) of c2 is displayed in the top row, and the height from the surface plate to the center of the inside diameter (difference in height with the set reference) is displayed in the bottom row.

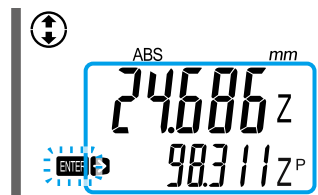

4 Press and hold [←] until a beep sound is made.

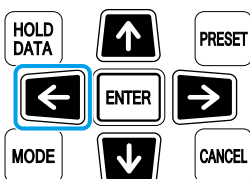

» The set reference will be cleared, and the regular condition will be restored.

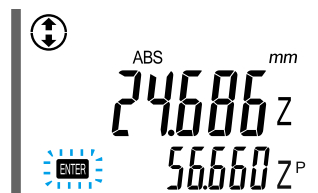

3.1.3 Calculating the Difference between Two Measurement Values Stored in Memory

By storing two measurement values in the product's internal memory and then calling them, the difference between the two measurement values can be calculated.

This section explains the procedure for calculating the height difference between s1 and s3 after measuring the height of s1, s2, and s3 in that order with the surface plate set as the ABS reference as shown below.

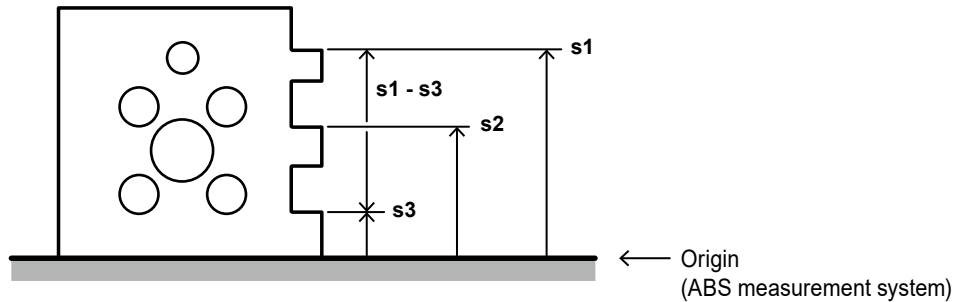

Tips

The measurement values stored in the memory will be erased when the power supply to the product is terminated by removing the batteries or unplugging the AC adapter (optional accessory).

1 Set the surface plate as the origin (ABS measurement system).

For details about the setup, see "• Setting the surface plate as the origin" on page 13.

2 Measure the height of s1.

For details about measuring height, see "2.2 Measuring the Height" on page 21.

» The measurement value for s1 is displayed.

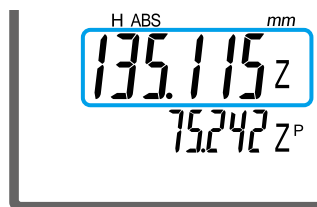

3 While the measurement value for s1 is displayed, press and hold [Inside diameter measurement] until a beep sound is made.



» The measurement value for s1 is stored in the memory, and [M1] (memory 1), which indicates the location of storage in the memory, is displayed on the bottom left of the LCD.



4 Measure the height of s2.

3 Specific Usage Applications

5 Measure the height of s3.

6 While the measurement value for s3 is displayed, press and hold [Outside diameter measurement] until a beep sound is made.



» The measurement value for s3 is stored in the memory, and [M2] (memory 2), which indicates the location of storage in the memory, is displayed on the bottom left of the LCD.

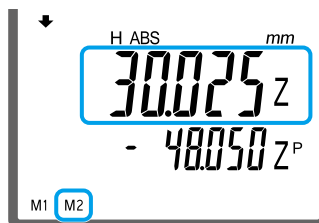

7 Calculate the difference between two measurement values stored in memory.

1 Press [MODE] twice.

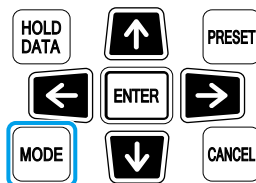

» Characters will be displayed in the bottom row of the LCD.

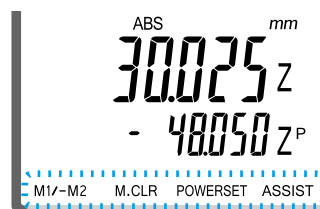

2 Press [Inside diameter measurement] to select [M1-M2] (memory calculation).



» The difference between two measurement values stored in [M1] and [M2] will be displayed.

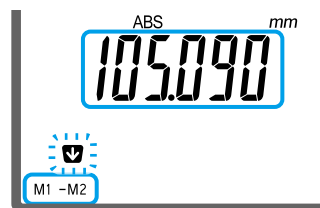

Tips

When [↕] is pressed, [M1/M2] will be displayed together with the ratio of two measurement values.

8 Press [CANCEL] twice.

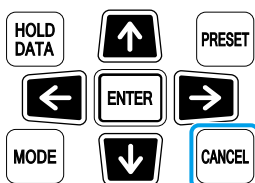

» The memory calculation will be cleared, and the regular condition will be restored.

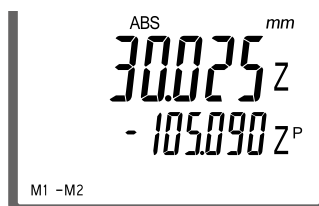

■ Erasing measurement values stored in the memory

1 Press [MODE] twice.

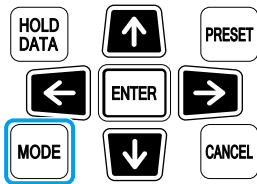

» Characters will be displayed in the bottom row of the LCD.

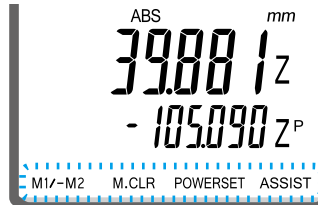

2 Press [Outside diameter measurement] to select [M.CLR] (memory clear).



» [M1] and [M2] will be displayed on the lower left of the LCD.



Tips

If measurement values are not stored in memory, [M1], [M2], and [M.CLR] will not be displayed.

3 Erase the measurement values.

To erase the value stored in both [M1] and [M2]

Press [ENTER].

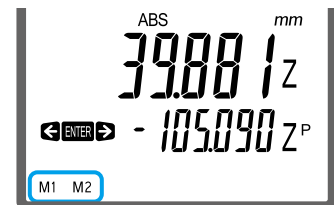
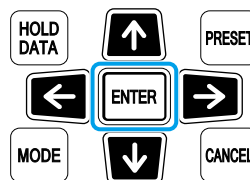

To erase the value stored in either [M1] or [M2]

Press [←] or [→] to select the target for deletion, and then press [ENTER].

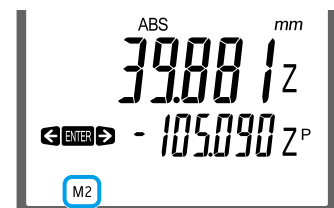
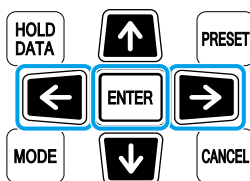

4 Press [CANCEL].

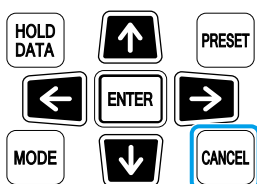

» The measurement value will be erased from the memory, and the regular condition will be restored.



3.2 Judging the Tolerance

By registering the upper and lower tolerance limits and enabling the GO/NG judgment function, the GO/NG judgment for measurement values can be automatically performed.

The result of GO/NG judgment will be indicated by the LED lamp on the operation panel or in the LCD.

You can easily determine whether the measurement value falls within the tolerance range.

Operation panel (LED display)



Red: The upper tolerance limit has been exceeded.
Green: The value is within the tolerance range.
Orange: The value is below the lower tolerance limit.

LCD



[NG+]: The upper tolerance limit has been exceeded.
[GO]: The value is within the tolerance range.
[-NG]: The value is below the lower tolerance limit.

Tips

You can change the length of time during which the LED is lit. For details about the setup method, see ["3.7 Setting the LED Lighting Time"](#) on page 50.

3.2.1 Setting the Upper and Lower Tolerance Limits

As an example, the procedure for setting the upper tolerance limit [+100.010mm] and lower tolerance limit [+99.995mm] is explained below.

Tips

- The set tolerance limits are retained in memory even if the power is turned off.
- If the upper tolerance limit is set to a value that is lower than the value set for the lower tolerance limit, there will be an error.

1 Press [MODE].

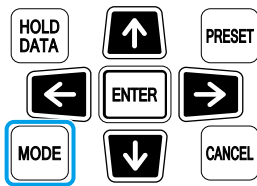

» Characters and icons will be displayed in the bottom row of the LCD.

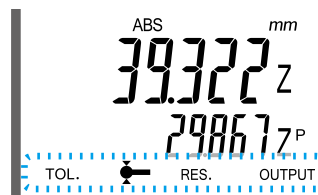

2 Press [Inside diameter measurement] to select [TOL.] (tolerance setting).



» [U] and the current upper tolerance limit will be displayed on the LCD.

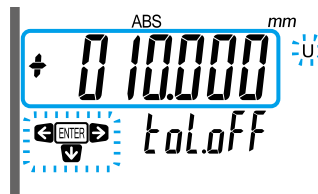

3 Press [→] to make [+] blink.

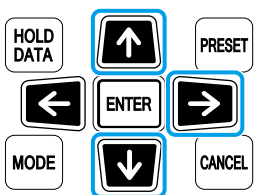

» [+] will blink.

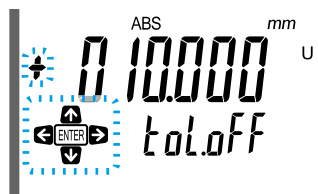

If [-] is blinking, press [↑] or [↓] to change the display to [+].

4 Repeatedly press [→] until the value in the hundreds place flashes.

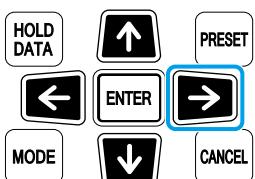

» The value in the hundreds place will flash.

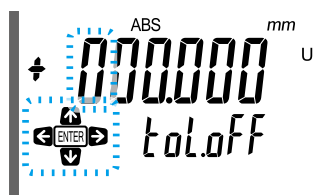

3 Specific Usage Applications

5 Press [\uparrow] or [\downarrow] to display [1].

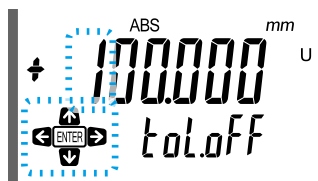
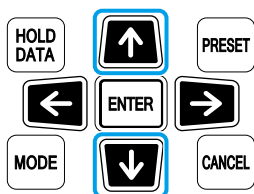

6 Display [1] in the second position after the decimal using the same procedure described in steps **4** and **5**.

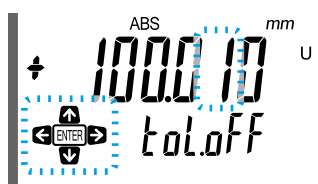

7 Press [ENTER].

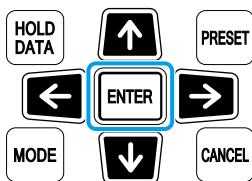

» The current lower tolerance limit will be displayed on the LCD, and [L] will blink.

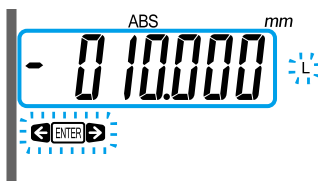

8 With the same procedure as in steps **3** through **5**, set the lower tolerance limit to [+99.995mm].

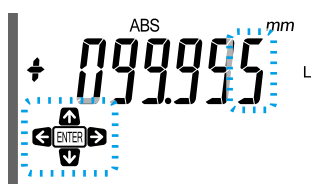

9 Press [ENTER].

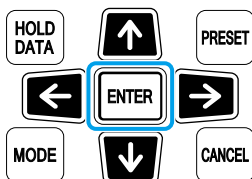

» The setting of the tolerance limit values is complete, and the regular condition will be restored.

3.2.2 Enabling/Disabling the Judgment Function

1 Press [MODE].

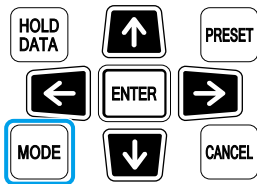

» Characters and icons will be displayed in the bottom row of the LCD.



2 Press [Inside diameter measurement] to select [TOL.] (tolerance setting).



» [U] and the current upper tolerance limit will be displayed on the LCD.

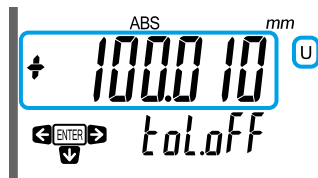

3 Press [↓].

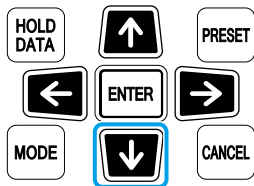

4 Press [←] or [→] and select [toL.on] (enabled) or [toL.off] (disabled).

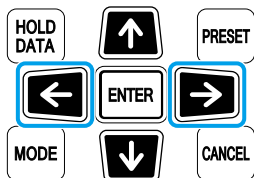

5 Press [ENTER].

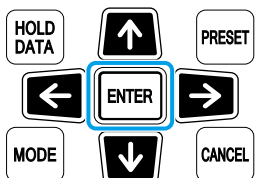

» The selection will be finalized.

6 Press [CANCEL].

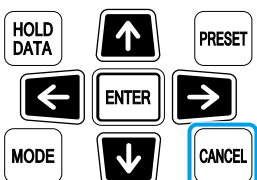

» The regular condition will be restored.

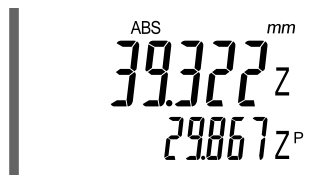

3.3 Setting the Termination Method of Scanning Measurements

When measuring an inside or outside diameter using a scanning measurement, set the termination method of the scanning measurement (automatic termination or manual termination). [Auto] (automatic termination) is the default setting.

1 Press [MODE].

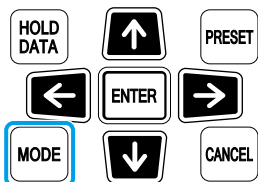

» Characters and icons will be displayed in the bottom row of the LCD.



2 Press [Outside diameter measurement] and select the icon for [Probe settings].



3 Press [←] or [→] to display the following screen.

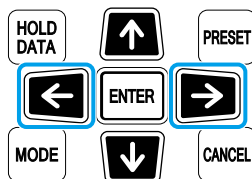

» Depending on the current setting, [Auto] (automatic termination) or [ENTER] (manual termination) will be displayed.



4 Press [↑] or [↓] and select the termination method of the scanning measurement ([Auto] or [ENTER]).

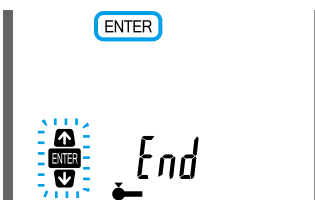
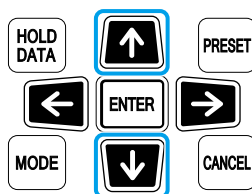

Selections	Termination method
[Auto]	The lowest point and highest point will be detected automatically, a beep sound will be made, and the scanning measurement will terminate automatically.
[ENTER]	Press [ENTER] to manually terminate the scanning measurement.

5 Press [ENTER].

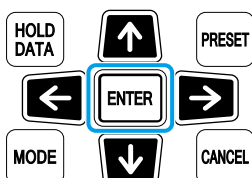

» The setup is complete and the regular condition will be restored.

3.4 Registering the Order of Measurements

"Perform measurements in the following order: height at four points, inside diameter at four points, and outside diameter at two points." When performing measurements with a combination of multiple items in a set order, it is beneficial to register the order. Because the measurement items are automatically performed in the registered order, the overall operation is simplified.

There is one type of order that can be registered including up to 10 of the following measurement items.

- Bottom surface measurement
- Top surface measurement
- Inside diameter measurement
- Outside diameter measurement
- Plane scanning measurement

Tips

For details about each measurement item, see  "3 Specific Usage Applications" on page 33.

Register up to 10 measurement items such as for height or inside diameter in the order to be measured.

1 Press [MODE] twice.

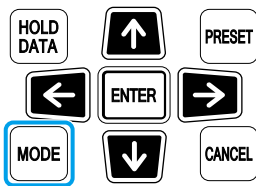

» Characters will be displayed in the bottom row of the LCD.



2 Press [ZERO/ABS] to select [ASSIST] (assist function).



» The registered steps will be displayed.

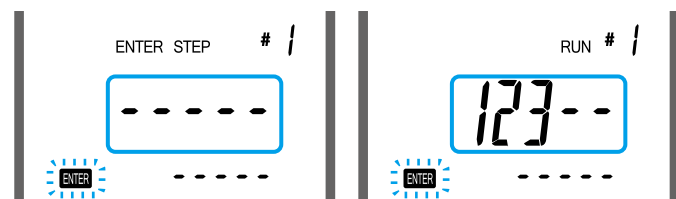

If no steps are registered

If steps are registered

3 If steps are registered, press [←], and select [ENTER STEP], and then press [ENTER].

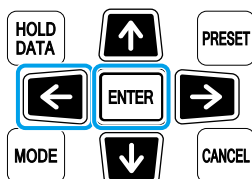

3 Specific Usage Applications

4 Press [ENTER].

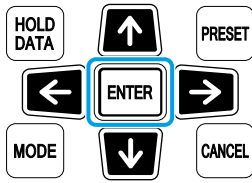

» The step registration is ready to begin (new registration).

5 Register the measurement items in the order to be measured.

1 Refer to the following and press the key for the measurement item to be registered as the first step. For example, press [↓] to register a top surface measurement ⑤.

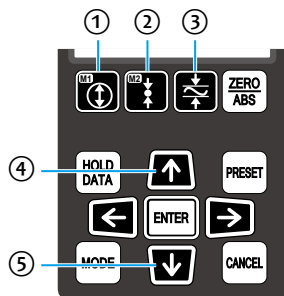

Key	Measurement item	Number
①	Inside diameter measurement	1
②	Outside diameter measurement	2
③	Plane scanning measurement	3
④	Bottom surface measurement	4
⑤	Top surface measurement	5

» [5] (top surface measurement) will be displayed, and the blinking cursor will move to the right.

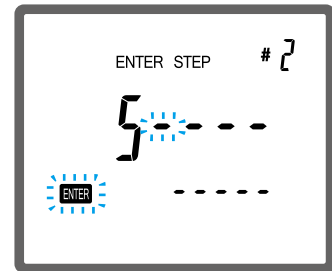

2 Register the subsequent measurement items in the same way as 1.

» Setting the 10th step completes the registration. The first registered measurement item will then be automatically called.

Tips

To complete the registration before the 10th step, press [ENTER]. The first registered measurement item will then be automatically called.

6 Press [CANCEL].

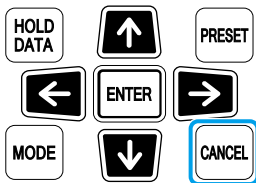

» Proceed to step 5 in "3.4.1 Measuring Using the Registered Measurement Steps" on page 46 and perform the measurements.

3.4.1 Measuring Using the Registered Measurement Steps

1 Press [MODE] twice.

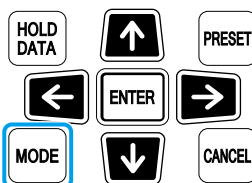

» Characters will be displayed in the bottom row of the LCD.

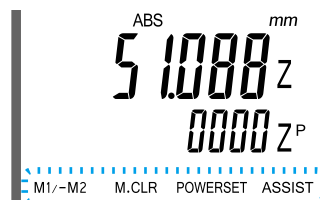

2 Press [ZERO/ABS] to select [ASSIST] (assist function).

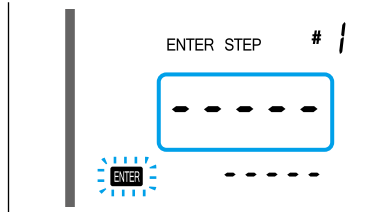

3 Press [←] or [→] to select [RUN].

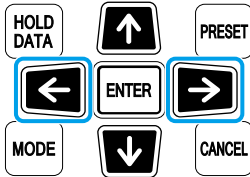

Examples of registrations

1st: Top surface measurement

2nd: Top surface measurement

3rd: Inside diameter measurement

4 Press [ENTER].

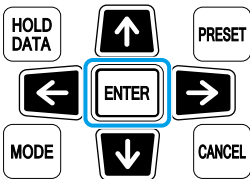

» The first registered measurement item will then be called.



5 Perform measurements using the first registered measurement item.

For details about making measurements, see » "2 Basic Measuring Methods" on page 11.

For inside diameter measurements, outside diameter measurements, and plane scanning measurements, press [ENTER] after the measurements are completed.

» After the measurement is completed, the second registered measurement item will be called.

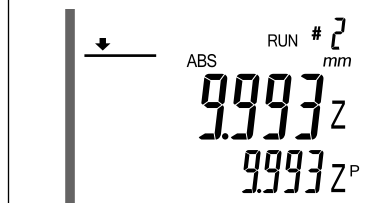

6 To continue measuring press [ENTER]; to finish measuring press [CANCEL].

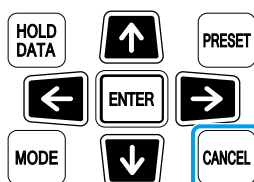
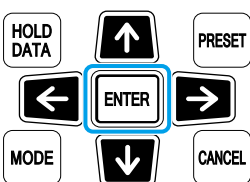

3.5 Setting the Resolution for Measurement Values

You can change the resolution of the LCD.

Tips

The default setting is [0.001 mm] for models that support millimeters and [0.00005 in] for models that support inches.

1 Press [MODE].

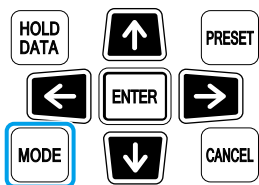

» Characters and icons will be displayed in the bottom row of the LCD.



2 Press [Scanning measurement] to select [RES.] (resolution setting).

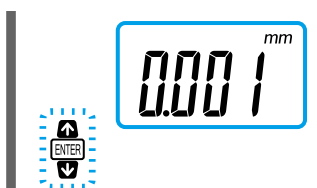

3 Press [↑] or [↓] to select the resolution.

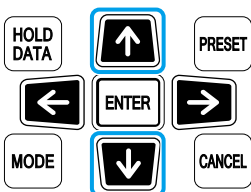

» If [0.005] is selected

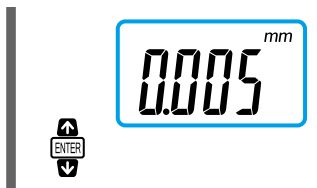

Setting	Details
[0.001]	Resolution: 0.001 mm
[0.005]	Resolution: 0.005 mm

4 Press [ENTER].

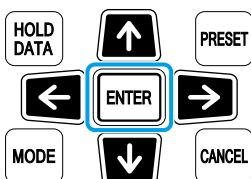

» The setup is complete and the regular condition will be restored.

3.6 Setting the Time until the Power Turns Off (Auto-Off)

Auto-off is a function that automatically turns off the product if it is not used for a specified period of time. This section explains how to set the length of time until the auto-off function activates.

Tips

[2min] (2 minutes) is the default setting.

1 Press [MODE] twice.

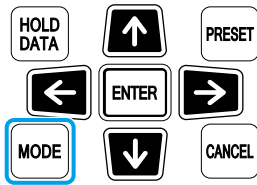

» Characters will be displayed in the bottom row of the LCD.



2 Press [Scanning measurement] to select [POWER SET] (power setting).



3 Press [↑] or [↓] and select the length of time until the auto-off function activates.

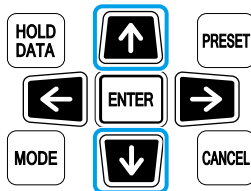

» If [5min] is selected

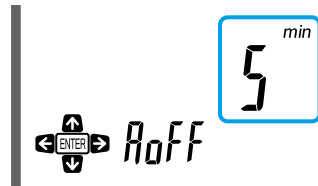

Setting	Details
[2min]	The power is turned off if there is no operation for 2 minutes.
[5min]	The power is turned off if there is no operation for 5 minutes.
[oFF]	Disables the auto-off function.

4 Press [ENTER].

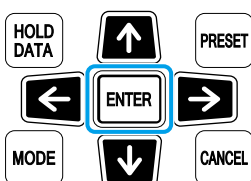

» The setup is complete and the regular condition will be restored.

3.7 Setting the LED Lighting Time

Set the time during which the LED is lit for the tolerance judgment.

Tips

- [3 SEc] (3 seconds) is the default setting.
- If the batteries deplete quickly, you can set the LED lighting to off.

1 Press [MODE] twice.

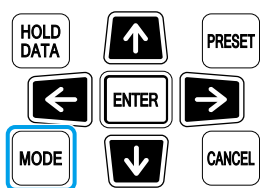

» Characters will be displayed in the bottom row of the LCD.



2 Press [Scanning measurement] to select [POWER SET] (power setting).



3 Press [←] or [→].

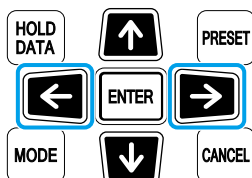

» The screen for setting how long the LED is lit is displayed.

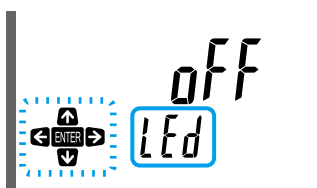

4 Press [↑] or [↓] to select the length of time for the LED to be lit.

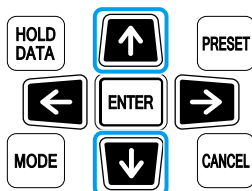

» If [ALL] is selected

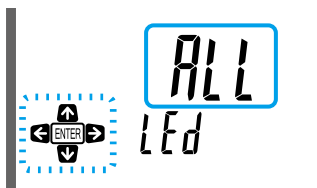

Setting	Details
[3 SEc]	Lights for 3 seconds.
[ALL]	Stays continuously lit.
[oFF]	Turns off the light.

5 Press [ENTER].

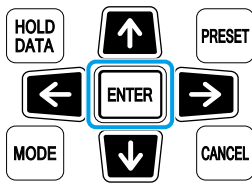

- » The setup is complete and the regular condition will be restored.

3.8 Outputting Measurement Results to an External Device

Data can be output to the mini printer (optional accessory) or sent to the PC in accordance with the application of the measurement results.

3.8.1 Selecting the Displayed Value to Be Output

Only the value displayed in either the top (measurement value) or bottom (calculated value) row of the LCD can be output to an external device as the measurement result.

For details about the value displayed in the bottom row, see  "3.1 Calculating the Difference between Two Measurement Values" on page 33.

By default, the product is set to output the value displayed in the top row of the LCD. If outputting the value displayed in the bottom row, perform the following operation to change the setting.

1 Press [MODE].

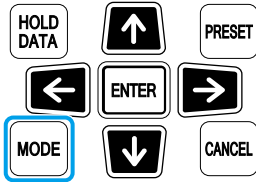

» An icon will be displayed in the bottom row of the LCD.



2 Press [ZERO ABS] to select [OUTPUT] (output setting).

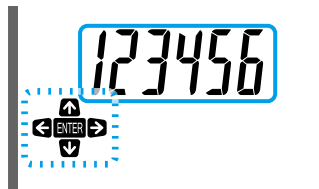

3 Press [↓] to select the bottom row.

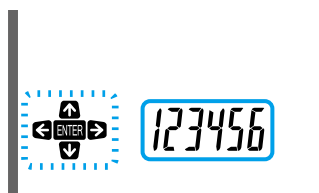
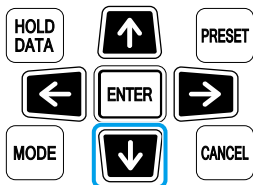

4 Press [ENTER].

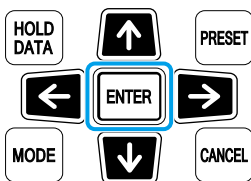

» The setup is complete and the regular condition will be restored.

3.8.2 Outputting Data to a Mini Printer (Optional Accessory)

Connecting the Digimatic mini-processor (DP-1 series, optional accessory) to the Digimatic output connector of this product will allow you to output measurement results. The measurement results will automatically be output upon completion of measuring.

Tips

- Measurement results can also be output by pressing the [HOLD DATA] key, but they will not be output while scanning measurements are performed.
- You can also output measurement results by operating an external device (optional accessory). For details, see the user's manual for the Digimatic mini-processor.

■ Specifying the number of digits of the measurement value to output

You can specify either [out-d1] (Digimatic output) or [out-d2] (Digimatic 2 output) according to the number of digits that the connected DP-1 series device can accept. Use the following procedures to specify the number of digits of the measurement value to output.

Tips

[out-d1] (Digimatic output) is the default setting.

1 Press [MODE].

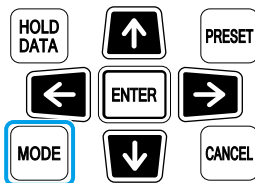

- » Characters and icons will be displayed in the bottom row of the LCD.

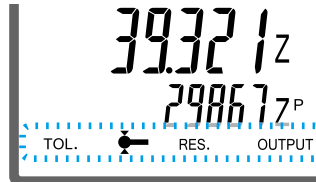

2 Press [ZERO ABS] to select [OUTPUT] (output setting).

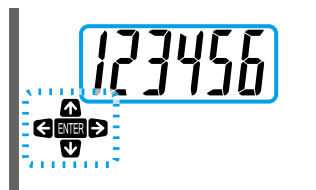

3 Press [←] or [→].

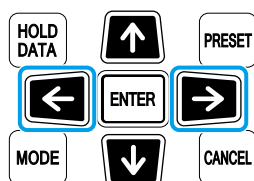

- » The screen for setting the number of digits of the measurement value to output is displayed.

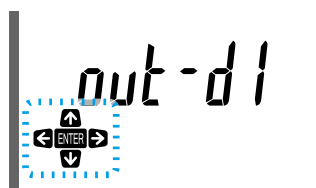

3 Specific Usage Applications

- 4** Press [\uparrow] or [\downarrow] and select the setting for the number of digits of the measurement value to output.

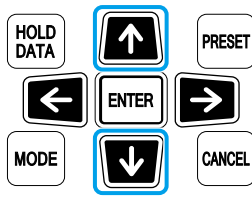

» If [out-d2] is selected



Setting	Details
[out-d1]	Outputs six digits of the measurement value. Use this setting if connecting to a DP-1 series device that is not compatible with 8-digit outputs.
[out-d2]	Outputs eight digits of the measurement value. Use this setting if connecting to a DP-1 series device that is compatible with 8-digit outputs.

- 5** Press [ENTER].

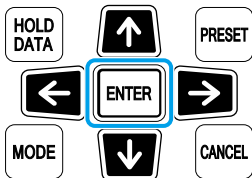

» The setup is complete and the regular condition will be restored.

If the resolution for models that support inches is set to [0.00005 in] and [out-d1] is selected at the step **4**, you can change which six digits in the measurement are output. By default, the lowest six digits are set to be output. For example, in [22.12345 in], [2.12345 in] will be output.

- 6** Change the output to the highest six digits.

- 1 Press [MODE]
 - » Characters and icons will be displayed in the bottom row of the LCD screen.
- 2 Press [ZERO/ABS] to select [OUTPUT] (output setting).
- 3 Press [\leftarrow] or [\rightarrow] until [888888] is displayed.
- 4 Press [\uparrow] or [\downarrow] to select [88.8888] (the highest 6 digits), and then press [ENTER].
 - » Setup is complete.

3.8.3 Outputting Data to a PC (Windows Only)

By preparing commercially-available communication software and connecting this product to your Windows PC using a micro USB Type-A cable, you can send measurement results to the PC.

For details about the communication specifications, see  "6.2.2 USB Data Output Specifications" on page 67.

Tips

Only the value displayed in either the top (measurement value) or bottom (calculated value) row of the LCD can be output to an external device as the measurement result.

For details about the value displayed in the bottom row, see  "3.1 Calculating the Difference between Two Measurement Values" on page 33.

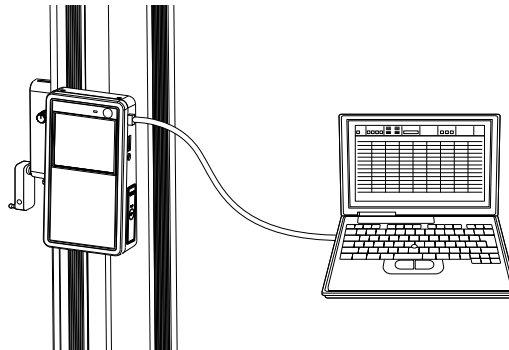

A dedicated communication driver must be installed on the PC to send the data. The system requirements for the communication driver are provided below.

Items	Operating environment
OS	Windows 10/Windows 8/Windows 7/Windows Vista
HDD capacity	500 KB or more
Display	800 x 600 resolution or higher, 256 colors or more
Other	Separate communication software is required. We recommend using the standard USB port on the main unit (the usage of other USB ports are not officially supported). Internet access is required.

Tips

Data can also be sent by using a USB input tool (optional accessory) or U-WAVE (optional accessory). For details, see the user's manual for each product.

■ Installing the USB communication driver on your PC

- 1 Access Mitutoyo's website from your PC to download the USB communication driver for QM-Height.**

<http://www.mitutoyo.co.jp/global.html>

- 2 Install the downloaded driver on the PC.**

Tips

During installation, use a registered COM port number.

■ Sending measurement results to your PC

1 Connect the product to your PC using a commercially available micro USB Type-A cable.

Tips

When the cable is connected, the product is in the USB communication state, which depletes the batteries. Remove the cable when not in use.

2 Run the commercially-available communication software from the PC.

Tips

The communication setups for the communication software should be subject to  "■ Communication specifications" on page 67.

3 Perform a measurement.

» The measurement results will be automatically sent to the PC.

Tips

- For details about measurement methods, see  "3 Specific Usage Applications" on page 33.
- Data can also be sent by pressing the [HOLD DATA] key.

4 Troubleshooting

If a problem occurs while using this product, try one of the solutions provided below. If the solutions do not resolve the problem, contact the agent where you purchased the product or Mitutoyo sales representative for a repair.

4.1 If the Following Problem Occurs

Based on the problem, determine the cause and the solution.

Problem	Cause	Solution
The power does not turn on when [Power button] is pressed.	The batteries are not inserted correctly.	Reinsert the batteries.
	The batteries have died.	Replace the batteries with new ones.
	The AC adapter (optional accessory) is not properly connected.	Reconnect the AC adapter (optional accessory).
The batteries are depleted quickly.	The LED is set for continuous use.	<ul style="list-style-type: none"> Change the setting of the LED lighting. <p>Tips For details, see  "3.7 Setting the LED Lighting Time" on page 50.</p> <ul style="list-style-type: none"> Remove the batteries if the product will not be used for an extended period of time.
The air-float function does not work (the battery depletion icon is only lit when the air-float switch is pressed).	The batteries are too low for the air-float function to operate.	<ul style="list-style-type: none"> Replace all four batteries with new ones. Connect an AC adapter (optional accessory). <p>Tips</p> <ul style="list-style-type: none"> The air-float function uses an excessive amount of electrical power. If you use this function often, using an AC adapter (optional accessory) is recommended. When using the air-float function, the battery life (until the air-float function no longer operates) is around 1.5 hours.
Measurements are not made even when the tip of the stylus comes in contact with a workpiece (there is no beep sound).	The clamp knob is locked.	Loosen the clamp knob.
The displayed value is being held, and the workpiece cannot be measured ([H] remains displayed on the LCD).	The displayed value is held.	Press the [HOLD DATA] key to release the hold on the value.
	The clamp knob is locked.	Follow the instructions in "■ When the counter value is held, and the measurement cannot be made" on page 58 to loosen the clamp knob.

Problem	Cause	Solution
There is variance in the measurement values.	The tip of the stylus contacted the workpiece with excessive force.	Slowly bring the tip of the stylus into contact with the workpiece.
	The holder clamp knob is loosened.	Tighten the holder clamp knob.
The probe unit vibrates when making plane scanning measurements.	In some cases, the probe unit vibrates depending on the condition of the surface of the workpiece.	Change the spanning direction, and if the vibration stops, limit the movements to that direction.
<ul style="list-style-type: none"> The display temporarily flickers or disappears. Normal measurement results cannot be obtained. The power automatically turns off. 	The product is used in environments where electromagnetic interference exceeds requirements defined in the EMC Directive.	<ul style="list-style-type: none"> The product returns to the normal operation when the electromagnetic interference caused by static electricity is eliminated. If the AC or DC power line experiences electromagnetic interference, measure again after checking the power line's surrounding area. If the voltage of the power supply decreases, the product will return to normal operation after the voltage is restored.

■ When the counter value is held, and the measurement cannot be made

Ensure that metal fitting A of the probe unit is roughly in the center between metal fitting B and C.

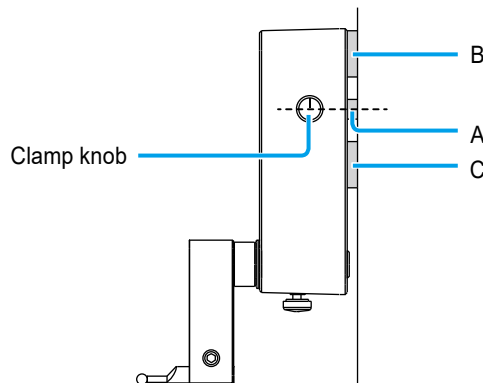

● Making adjustments to center the fittings

1 Turn the clamp knob counterclockwise.

» Fitting A will move to the center between fittings B and C (fitting A is in a position even with the clamp knob).



2 Turn the clamp knob clockwise until fitting A is reached.

3 Turn the clamp knob counterclockwise about five times.

» The hold will be released, and measurements can be made again.

4.2 If Error Messages Are Displayed

Based on the error displayed on the LCD, determine the cause and the solution.

Error message	Cause	Solution
	The batteries are depleted.	<ul style="list-style-type: none"> • Replace all four batteries with new ones. • Connect an AC adapter (optional accessory).
Err-30F	The displayed value exceeds the number of displayable digits.	This warning will automatically be cleared when the value falls within the displayable range.
<ul style="list-style-type: none"> • XXX XXE (X is an arbitrary value) • Err-48A 	<p>An abnormality occurred in the signal from the positioning detection sensor.</p> <p>E.g.: The position of the sensor is off due to a physical shock or there are foreign materials inside.</p>	If the display is not restored even when the probe unit is stopped, the positioning detection sensor may have a failure. Contact the nearest Mitutoyo sales office.
Err-90t	The lower tolerance limit set for the tolerance is higher than the upper tolerance limit.	<p>Set the lower tolerance limit so that it is below the upper tolerance limit.</p> <p>Tips</p> <p>For details, see  "3.2.1 Setting the Upper and Lower Tolerance Limits" on page 41.</p>
Err-96P	A negative value is set for the ball diameter.	<p>Retry the ball diameter setting.</p> <p>Tips</p> <p>For details, see  "2.1.2 Setting the Diameter of the Ball on the Tip of the Stylus" on page 18.</p>
Err-40S	A critical error has occurred.	Contact the agent where you purchased the product or Mitutoyo sales representative for a repair.

MEMO

5 Maintenance

This chapter explains daily inspections, cleaning, and storage. In order to properly utilize the product's capabilities and to be able to use the product safely for a long period of time, perform the following.



Do not use detergents or organic solvents such as thinners or benzine.
The surface paint of the product may peel off or change color.



In order to prevent dirt and dust accumulation on the main unit, we recommend covering it with the supplied product cover after use.

■ Daily inspections

Check the exterior of the product for dirt or scratches.

■ Cleaning

Lightly wipe dirt away from the main unit, base, and probe unit with a soft cloth that does not leave fibers (silicon cloth, etc.).

Wipe dirt away from the stylus using alcohol.

■ Storage

When the product will not be used for a long period of time, put it in its storage box and store away from direct sunlight and high temperature and humidity. For details about how to store the product, see  the separate "Setup Manual".

MEMO

6 Specifications

6.1 Basic Specifications

Code No.	Metric	518-240	518-242	518-244	518-246
	Inch/Metric	518-241	518-243	518-245	518-247
Model number	Metric	QMH-350AX	QMH-600AX	QMH-350BX	QMH-600BX
	Inch/Metric	QMH-14"AX	QMH-24"AX	QMH-14"BX	QMH-24"BX
Measuring range (stroke)		0 mm–465 mm (350 mm/14")	0 mm–715 mm (600 mm/24")	0 mm–465 mm (350 mm/14")	0 mm–715 mm (600 mm/24")
Resolution	Metric	0.001 mm / 0.005 mm			
	Inch/Metric	0.001 mm / 0.005 mm / 0.00005" / 0.0001" / 0.0002"			
Accuracy (20 °C)	Indication accuracy ^{*1}	$\pm(2.4 + 2.1L/600) \mu\text{m}$			
	Repeatability ^{*1}	$2\sigma \leq 1.8 \mu\text{m}$			
Perpendicularity ^{*2} (forward and backward direction) (20 °C)		7 μm	12 μm	7 μm	12 μm
Guiding method		Roller bearing			
Driving method		Manual (wheel drive)			
Detection method		Electromagnetic induction absolute encoder			
Measuring force		$1.5 \pm 0.5 \text{ (N)}$			
Data output		Digimatic output / Digimatic 2 output / USB ^{*3}			
Air-float function		N/A		Available (only for moving the main unit) ^{*4}	
Power supply		AA alkaline batteries x4 (supplied), AC adapter (optional accessory), rechargeable nickel-metal hydride batteries x4 are supported ^{*5}			
Estimated battery life ^{*6}	Continuous use (without using the air-float function)	LED is not constantly lit: About 1200 hours LED is constantly lit ^{*9} : About 100 hours			
	Normal use ^{*7} (without using the air-float function)	LED is not constantly lit: About 80 days LED is constantly lit ^{*9} : About 13.5 days			
	When the air-float function is used ^{*8,*9}	-		LED is not constantly lit: About 3.8 days LED is constantly lit: About 2/3 of the above estimate	
Weight		25 kg	29 kg	25 kg	29 kg
Dimensions		QMH-350AX/QMH-350BX/QMH-14"AX/QMH-14"BX : 280 (W) × 273 (D) × 784 (H) mm QMH-600AX/QMH-600BX/QMH-24"AX/QMH-24"BX : 280 (W) × 273 (D) × 1016 (H) mm			
Operating temperature range (recommended)		0 °C–40 °C (10 °C–30 °C)			
Operating humidity range		20 %RH–80 %RH (with no condensation)			
Storage temperature range		-10 °C–50 °C			

6 Specifications

Storage humidity range	5 %RH–90 %RH (with no condensation)
CE marking	EMC Directive EN61326-1 Immunity test requirement: Clause 6.2 Table 2 Emission limit: Class B RoHS Directive EN50581

- ^{*1} The indication accuracy and repeatability indicate the values obtained from the height measurement of a flat surface using the supplied $\varnothing 5$ stepped probe. For measuring diameter, maximum (minimum) value, displacement, or circular pitch, the measurement accuracy may be greater than the accuracy ratings listed in the table because, unlike height measurements, the measuring force changes while scanning measurements are processed.
- ^{*2} Perpendicularity indicates the values obtained from the measurement of a flat surface placed parallel with the reference plane of the base by using Mitutoyo's lever head probe (MLH-521) and electronic micrometer (M-551).
- ^{*3} A USB communication driver is required.
It can be downloaded from the Mitutoyo homepage. <http://www.mitutoyo.co.jp/global.html>
- ^{*4} To use models equipped with the air-float function, use a surface plate of JIS1 Class or above. If the surface plate is scratched or uneven, the specified performance may not be achieved.
- ^{*5} The AC adapter cannot be used to recharge rechargeable batteries.
- ^{*6} The life of the batteries will vary depending on how the product is used.
Recommended nickel-metal hydride batteries: 1,900 mAh or greater capacity
- ^{*7} Calculated values assuming about 5 hours of use a day.
- ^{*8} Calculated values assuming about 0.5 hours of use a day.
- ^{*9} If the LED is set to be constantly lit or the air-float function will be frequently used, using an AC adapter (optional accessory) is recommended.

6.2 Data Output Specifications

6.2.1 Digimatic Data Output

■ Data format

● Digimatic output

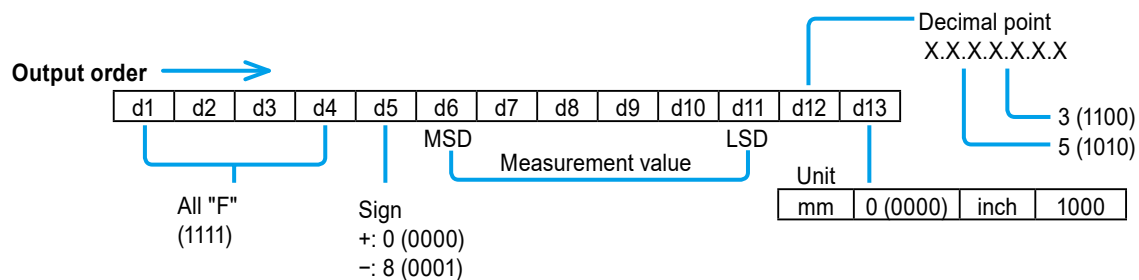

(Example) Normal measurement of 0.123 mm



● Digimatic 2 output

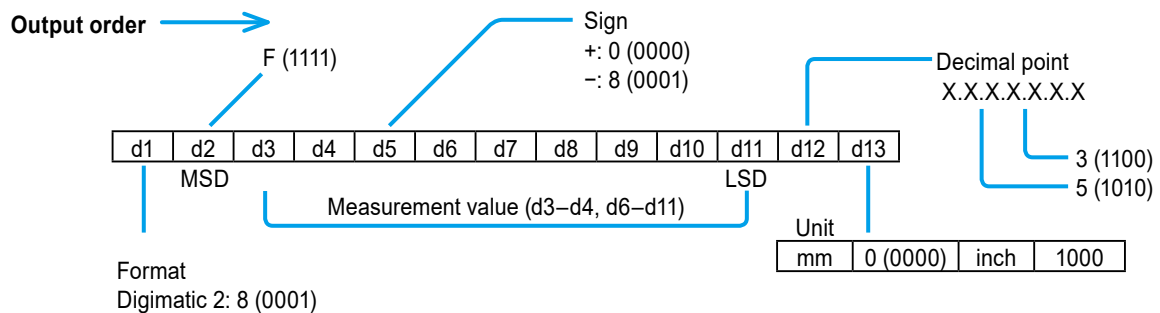

(Example) Normal measurement of 0.123 mm

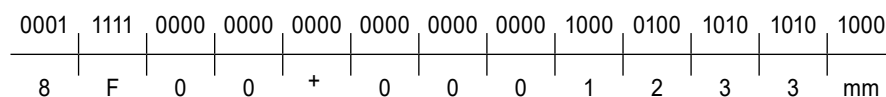

Tips

- For details about how to set the number of digits of the measurement value to output, see "3.8.2 Outputting Data to a Mini Printer (Optional Accessory)" on page 53.
- Seven digits are enabled when the resolution is set to [0.00005 in]. Due to our Digimatic data output specifications, all of these digits cannot be output simultaneously. Generally, the value in the 10s place (the highest value position) will be excluded, and only the remaining six digits will be output. However, it is possible to change the settings so that the digit with the highest value is output. For details, "3.8.2 Outputting Data to a Mini Printer (Optional Accessory)" on page 53.

■ Connector specifications

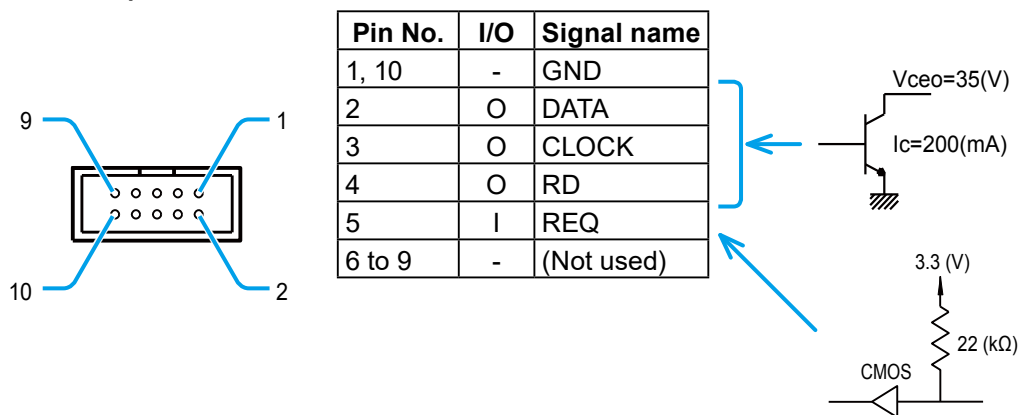

■ Timing chart

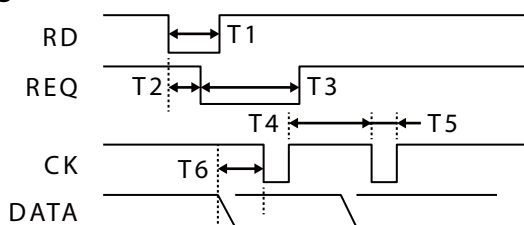

T1	2 sec (max)
T2, T3	Differs according to the connected device
T4	430 μs (Typ.)
T5	200 μs (Typ.)
T6	200 μs (Typ.)

6.2.2 USB Data Output Specifications

■ Communication specifications

Communication method	Half-duplex communication
Communication speed	9600 bps
Start bit	1
Data bit	8
Parity bit	N/A
Stop bit	1

■ Data format

D1	Code No.	"0" (fixed)
D2	Channel No.	"1" (fixed)
D3	Measurement item	"A" (fixed)
D4		"+" or "-" sign
D5 to D12		DATA (floating decimal point)
D13		Carriage return

■ Connector specifications

Pin No.	Signal name	Name
1	Vbus	Power supply (5V) from the PC
2	D-	Communication with the PC (-)
3	D+	Communication with the PC (+)
4	N.C.	Connected to signal GND
5	GND	Signal GND

■ Data format examples

Unit system	Resolution	Output format
mm	0.001	0.123 → 01A+0000.123[CR]
	0.005	0.125 → 01A+0000.125[CR]
inch	0.00005	0.12345 → 01A+00.12345[CR]
	0.0001	0.1234 → 01A+000.1234[CR]
	0.0002	0.1234 → 01A+000.1234[CR]

6.3 Accessories

■ Standard accessories

Part No.	Name	Quantity
05HZA148	ø5 stepped probe	1
12AAA715	Ball diameter calibration block	1
06AEW407	Rubber cap (A)	2
06AEW408	Rubber cap (B)	1
06AEX945	Cable clamp	1
06AEW863 ^{*1}	Product cover	1
06AEW864 ^{*2}	Product cover	1
05HAA412	Allen wrench (nominal 5)	1
-	AA alkaline batteries ^{*3}	4
99MAF600B	User's Manual (this document)	1
99MAF601M	Setup Manual	1
99MAF602M	Quick Reference Manual	1
-	Certificate of inspection	1
-	Warranty card	1

^{*1} QMH-350AX/QMH-350BX/QMH-14"AX/QMH-14"BX only

^{*2} QMH-600AX/QMH-600BX/QMH-24"AX/QMH-24"BX only

^{*3} Products with "-1" at the end of their code numbers do not include batteries.

Tips

The supplied batteries are used only for the purpose of checking the functions and performance of the product. Therefore, they may not fulfill the specified battery life.

■ Fastening parts for transportation

Part No.	Name	Quantity
05HZA196	Column fastening screw	2
06AEW164	Weight fastening screw	1
06AEW165	Probe fastening board	1
05HAA632	Hexagon socket head cap screw (M6 x 25)	1

6.4 Optional Accessories

Part No.	Name
• Depth measuring probe	
12AAC072	Depth probe
• Replacement stylus for ø5 stepped probe	
957261	ø2 ball stylus (coaxial type)
957262	ø3 ball stylus (coaxial type)
957263	ø4 ball stylus (coaxial type)
957264	ø14 disk stylus
957265	ø20 disk stylus
12AAA788	ø4 ball stylus (eccentric type)
12AAA789	ø6 ball stylus (eccentric type)
• Special holder, special probe	
12AAA792	Holder for dial gauge
12AAA793	Long holder
• AC adapter	
06AFZ950JA or 06AEG180JA	AD620JA (Japan/U.S. plug)
06AFZ950D or 06AEG180D	AD620D (for EU)
06AFZ950E or 06AEG180E	AD620E (for England)
06AFZ950K or 06AEG180K	AD620K (for Korea)
06AFZ950DC or 06AEG180DC	AD620DC (for China)
• Digimatic connecting cable	
936937	1 m
965014	2 m
• Other	
05HZA143	9 x 9 adapter (the following clamp is required)
05GZA033	Clamp (for 9 x 9 adapter)
05HZA144	6.35 x 12.7 adapter (the following clamp is required)
901385	Clamp (for 6.35 x 12.7 adapter)
02AZE990	U-WAVE mounting plate
05HZA173	Scriber* ¹

*¹ The scriber is used for making measurements. It cannot be used for markings.

Tips

The gauge blocks may be required for setting the origin or the reference depending on the probes and styli to be used.

Index

A

Accessories	68
Fastening parts for transportation	68
Standard accessories	68
Advanced measurements	33
Air-float function	8
Auto-off settings	49

B

Basic measuring methods	11
Basic operations	7
Before using this product	1

C

Calculating measurement differences	33
Calculation	34
Cleaning	61
Coarse movement	10
Conventions and wordings that indicate referential locations	i
Conventions that indicate mandatory actions	i

D

Daily inspections	61
Data output specifications	65
Digimatic data output	65
Disclaimer	vii
Disposal	v
Document map	viii

E

Electromagnetic compatibility (EMC)	iv
Enabling/disabling the judgment function	43
Environment for placement	iii
Error message	59
Export	iv

F

Fine movement	10
---------------------	----

L

LED light-time setting	50
Lower tolerance limit	41

M

Maintenance	iii, 61
Measuring an inside diameter	24
Measuring an outside diameter	27
Measuring steps and width	22
Measuring the displacement of a flat surface ..	30
Measuring the height	21
Measuring using the registered measurement steps	46
Memory	39
Moving the main unit	8
Moving the probe unit	10

N

Names and functions of each part	2
Display unit (liquid crystal display (LCD)) ..	6
Display unit (operation panel)	4
Main unit	2

O

Optional Accessories	69
Outputting to external devices	52
Outputting to a mini printer	53
Outputting to a PC	55

P

Power supply	iv
Precautions for use	iii
Preparing measurements	12
Origin setup (ABS measurement system) ..	13
Setting the origin or the reference	12

Problem 57
 Provision of technologyiv

R

Reference setup (INC measurement system) ... 16
 Registering the order of measurements 45
 Resolution settings 48

S

Safety precautions ii
 Safety reminder conventions and wordings i
 Setting the diameter of the ball on the tip of
 the stylus 18
 Specifications 63
 Basic specifications 63
 Storage 61
 Storing in the memory 37

T

Target audience and objectives viii
 Terminating scanning measurements 44
 This document viii
 Tolerance judgment 40
 Troubleshooting 57
 If a warning is indicated 59
 Problem 57
 Turning off the power 7
 Turning on the power 7

U

Upper tolerance limit 41
 USB data output specifications 67
 Communication specifications 67
 Connector specifications 67
 Data format 67
 Data format examples 67

W

Warranty vii

SERVICE NETWORK

*As of May 2020

Europe

Mitutoyo Europe GmbH

Borsigstrasse 8-10, 41469 Neuss, GERMANY
TEL: 49 (0)2137 102-0 FAX: 49 (0)2137 102-351

Mitutoyo CTL Germany GmbH

Von-Gunzert-Strasse 17, 78727 Oberndorf, GERMANY
TEL: 49 (0)7423 8776-0 FAX: 49 (0)7423 8776-99

KOMEG Industrielle Messtechnik GmbH

Zum Wasserwerk 3, 66333 Völklingen, GERMANY
TEL: 49 (0)6898 91110 FAX: 49 (0)6898 911100

Germany

Mitutoyo Deutschland GmbH

Borsigstrasse 8-10, 41469 Neuss, GERMANY
TEL: 49 (0)2137 102-0 FAX: 49 (0)2137 86 85

M³ Solution Center Hamburg

Tempowerkring 9-im HIT-Technologiepark 21079
Hamburg, GERMANY
TEL: 49 (0)40 791894-0 FAX: 49 (0)40 791894-50

M³ Solution Center Berlin

Ernst-Lau-Straße 6, 12489 Berlin, GERMANY
TEL:49(0)30 2611 267 FAX: 49 30 67988729

M³ Solution Center Eisenach

Neue Wiese 4, 99817 Eisenach,GERMANY
TEL: 49 (0)3691 88909-0 FAX: 49 (0)3691 88909-9

M³ Solution Center Ingolstadt

Marie-Curie-Strasse 1A, 85055 Ingolstadt, GERMANY
TEL: 49 (0)841 954920 FAX: 49 (0)841 9549250

M³ Solution Center Leonberg

Steinbeisstrasse 2, 71229 Leonberg, GERMANY
TEL: 49 (0)7152 6080-0 FAX: 49 (0)7152 608060

Mitutoyo-Messgeräte Leonberg GmbH

Heidenheimer Strasse 14, 71229 Leonberg, GERMANY
TEL: 49 (0)7152 9237-0 FAX: 49 (0)7152 9237-29

U.K.

Mitutoyo (UK) Ltd.

Joule Road, West Point Business Park,
Andover, Hampshire SP10 3UX, UNITED KINGDOM
TEL: 44 (0)1264 353 123 FAX: 44 (0)1264 354883

M³ Solution Center Coventry

Unit6, Banner Park, Wickmans Drive, Coventry,
Warwickshire CV4 9XA, UNITED KINGDOM
TEL: 44 (0)2476 426300 FAX: 44 (0)2476 426339

M³ Solution Center Halifax

Lowfields Business Park, Navigation Close, Elland,
West Yorkshire HX5 9HB, UNITED KINGDOM
TEL: 44 (0)1422 375566 FAX: 44 (0)1422 328025

M³ Solution Center East Kilbride

The Baird Building, Rankine Avenue, Scottish
Enterprise Technology Park, East Killbride G75
0QF, UNITED KINGDOM
TEL: 44 (0)1355 581170 FAX: 44 (0)1355 581171

France

Mitutoyo France

Paris Nord 2-123 rue de la Belle Etoile, BP 59267
ROISSY EN FRANCE 95957 ROISSY CDG
CEDEX, FRANCE
TEL: 33 (0)149 38 35 00

M³ Solution Center LYON

Parc Mail 523, cours du 3ème millénaire, 69791
Saint-Priest, FRANCE
TEL: 33 (0)149 38 35 70

M³ Solution Center STRASBOURG

Parc de la porte Sud, Rue du pont du péage,
67118 Geispolsheim, FRANCE
TEL: 33 (0)149 38 35 80

M³ Solution Center CLUSES

Espace Scionzier 480 Avenue des Lacs, 74950
Scionzier, FRANCE
TEL: 33 (0)1 49 38 35 90

M³ Solution Center TOULOUSE

Aeroparc Saint Martin Cellule B08 ZAC de Saint
Martin du Touch 12 rue de Caulet 31300
Toulouse, FRANCE
TEL: 33 (0)1 49 38 42 90

M³ Solution Center RENNES

2, rue Claude Chappe, PA le Vallon - ZAC Mivoie,
35230 Noyal-Châtillon-sur-Seiche, FRANCE
TEL: 33 (0)1 49 38 42 10

Italy

MITUTOYO ITALIANA S.r.l.

Corso Europa, 7 - 20020 Lainate (MI), ITALY
TEL: 39 02 935781 FAX: 39 02 9373290•93578255

M³ Solution Center BOLOGNA

Via dei Carpini1/A - 40011 Anzola Emilia (BO), ITALY
TEL: 39 02 93578215 FAX: 39 02 93578255

M³ Solution Center CHIETI

Contrada Santa Calcagna - 66020 Rocca S. Giovanni (CH), ITALY
TEL: 39 02 93578280 FAX: 39 02 93578255

M³ Solution Center PADOVA

Via G. Galilei 21/F - 35035 Mestrino (PD), ITALY
TEL: 39 02 93578268 FAX: 39 02 93578255

Netherlands

Mitutoyo Nederland B.V.

Wiltonstraat 25, 3905 KW Veenendaal,
THE NETHERLANDS
TEL: 31(0)318-534911

Mitutoyo Research Center Europe B.V.

De Rijn 18, 5684 PJ Best, THE NETHERLANDS
TEL:31(0)499-320200 FAX:31(0)499-320299

Belgium

Mitutoyo Belgium N.V. / M³ Solution Center Melsele

Schaarbeekstraat 20, B-9120 Melsele, BELGIUM
TEL: 32 (0)3-2540444

Sweden

Mitutoyo Scandinavia AB

Släntvägen 6, 194 61 Upplands Väsby, SWEDEN
TEL: 46 (0)8 594 109 50 FAX: 46 (0)8 590 924 10

M³ Solution Center Alingsås

Ängsvaktaregatan 3A, 441 38 Alingsås, SWEDEN
TEL: 46 (0)8 594 109 50 FAX:46 (0)322 63 31 62

M³ Solution Center Värnamo

Storgatsbacken 1, 331 30 Värnamo, SWEDEN
TEL: 46 (0)8 594 109 50 FAX: 46 (0)370 463 34

Switzerland

Mitutoyo (Schweiz) AG

Steinackerstrasse 35, 8902 Urdorf, SWITZERLAND
TEL: 41 (0)447361150 FAX: 41(0)447361151

Mitutoyo (Suisse) SA

Rue Gallée 4, 1400 Yverdon-les Bains, SWITZERLAND
TEL: 41 (0)244259422 FAX: 41 (0)447361151

Poland

Mitutoyo Polska Sp.z o.o.

Ul.Graniczna 8A, 54-610 Wroclaw, POLAND
TEL: 48 (0)71354 83 50 FAX: 48 (0)71354 83 55

Czech Republic

Mitutoyo Česko s.r.o.

Dubská 1626, 415 01 Teplice, CZECH REPUBLIC
TEL: 420 417-514-011 FAX: 420 417-579-867

Mitutoyo Česko s.r.o. M³ Solution Center Ivančice

Ke Karlovu 62/10, 664 91 Ivančice, CZECH REPUBLIC
TEL: 420 417-514-011 FAX: 420 417-579-867

Mitutoyo Česko s.r.o. M³ Solution Center Ostrava Mošnov

Mošnov 314, 742 51 Mošnov, CZECH REPUBLIC
TEL: 420 417-514-050 FAX:420 417-579-867

Mitutoyo Česko s.r.o. Slovakia Branch

Hviezdoslavova 124, 017 01 Povážská Bystrica, SLOVAKIA
TEL: 421 948-595-590

Hungary

Mitutoyo Hungária Kft.

Záhony utca 7, D-épület / fsz, 1031 Budapest, HUNGARY
TEL: 36 (0)1 2141447 FAX: 36 (0)1 2141448

Romania

Mitutoyo Romania SRL

1A Drumul Garii Odai Street, showroom, Ground Floor, 075100 OTOPENI-ILFOV, ROMANIA
TEL: 40 (0)311012088 FAX: +40 (0)311012089

Showroom in Brasov

Strada Ionescu Crum Nr.1, Brasov Business Park Turnul 1, Mezanin, 500446 Brasov-Judetul Brasov, ROMANIA
TEL/FAX: 40 (0)371020017

Russian Federation

Mitutoyo RUS LLC

13 Sharikopodshipnikovskaya, bld.2, 115088 Moscow, RUSSIAN FEDERATION
TEL: 7 495 7450 752

Finland

Mitutoyo Scandinavia AB Finnish Branch

Viherkiitäjä 2A, 33960, Pirkkala, FINLAND
TEL: 358 (0)40 355 8498

Austria**Mitutoyo Austria GmbH**

Salzburger Straße 260 / 3 A-4600 Wels, AUSTRIA
TEL: 43 (0)7242 219 998

Mitutoyo Austria GmbH Goetzis Regional showroom

Lastenstrasse 48a 6840 Götzis AUSTRIA

Singapore**Mitutoyo Asia Pacific Pte. Ltd.****Head office / M³ Solution Center**

24 Kallang Avenue, Mitutoyo Building,
SINGAPORE 339415

TEL:(65)62942211 FAX:(65)62996666

Malaysia**Mitutoyo (Malaysia) Sdn. Bhd.****Kuala Lumpur Head Office / M³ Solution Center**

Mah Sing Integrated Industrial Park, 4, Jalan Utarid U5/14,
Section U5, 40150 Shah Alam, Selangor, MALAYSIA

TEL:(60)3-78459318 FAX:(60)3-78459346

Penang Branch office / M³ Solution Center

30, Persiaran Mahsuri 1/2, Sunway Tunas, 11900
Bayan Lepas, Penang, MALAYSIA

TEL:(60)4-6411998 FAX:(60)4-6412998

Johor Branch office / M³ Solution Center

70 (Ground Floor), Jalan Molek 1/28, Taman
Molek, 81100 Johor Bahru, Johor, MALAYSIA

TEL:(60)7-3521626 FAX:(60)7-3521628

Thailand**Mitutoyo(Thailand)Co., Ltd.****Bangkok Head Office / M³ Solution Center**

76/3-5, Chaengwattana Road, Kwaeng Anusaowaree,
Khet Bangkaen, Bangkok 10220, THAILAND

TEL:(66)2-080-3500 FAX:(66)2-521-6136

Chonburi Branch / M³ Solution Center

7/1, Moo 3, Tambon Bowin, Amphur Sriracha,
Chonburi 20230, THAILAND

TEL:(66)2-080-3563 FAX:(66)3-834-5788

ACC Branch / M³ Solution Center

122/8, 122/9, Moo 6, Tambon Donhuaroh, Amphur
Muangchonburi, Chonburi 20000, THAILAND

TEL:(66)2-080-3565

Indonesia**PT. Mitutoyo Indonesia****Head Office / M³ Solution Center**

Jalan Sriwijaya No.26 Desa cibatu Kec. Cikarang
Selatan Kab. Bekasi 17530, INDONESIA

TEL: (62)21-2962 8600 FAX: (62)21-2962 8604

Vietnam**Mitutoyo Vietnam Co., Ltd****Hanoi Head Office / M³ Solution Center**

1st & 2nd floor, MHDI Building, No. 60 Hoang Quoc
Viet Road, Nghia Do Ward, Cau Giay District, Hanoi,
VIETNAM

TEL:(84)24-3768-8963 FAX:(84)24-3768-8960

Ho Chi Minh City Branch Office / M³ Solution Center

123 Dien Bien Phu Street, Ward 15, Binh Thanh
District, Ho Chi Minh City, VIETNAM

TEL:(84)28-3840-3489 FAX:(84)28-3840-3498

Philippines**Mitutoyo Philippines, Inc.****Head Office / M³ Solution Center**

Unit 1B & 2B LTI, Administration Building 1, Annex 1, North
Main Avenue, Laguna Technopark, Binan Laguna 4024,
PHILIPPINES

TEL:(63)49 544 0272 FAX:(63)49 544 0272

India**Mitutoyo South Asia Pvt. Ltd. Head Office**

C-122, Okhla Industrial Area, Phase-I,
New Delhi-110 020, INDIA

TEL:(91) 11-26372090 FAX: (91) 11-26372636

MSA Gurgaon technical center

Plot no. 65, Ground Floor, Udyog Vihar, Phase-4 Gurga-
on, Haryana - 122016

TEL : (91) 124-2340286/287

Mumbai Region Head office

303, Sentinel Hiranandani Business Park Powai,
Mumbai-400 076, INDIA

TEL:(91) 22-25700684/837/839 FAX: (91) 22-25700685

Pune Office / M³ Solution Center

G4/G5, Pride Kumar Senate, Off. Senapati Bapat
Road, Pune-411 016, INDIA

TEL:(91) 20-25660043/44/45 FAX: (91) 20-66033644

Bengaluru Region Head office / M³ Solution Center

No. 5, 100 Ft. Road, 17th Main, Koramangala, 4th
Block, Bengaluru-560 034, INDIA

TEL:(91) 80-25630946/47/48 FAX: (91) 80-25630949

Chennai Office / M³ Solution Center

No. 624, Anna Salai Teynampet, Chennai-600 018, INDIA

TEL: (91) 44-24328823/24

FAX: (91) 44-24328825

Kolkata Office

Unit No. 1208, Om Tower, 32, J.L..Nehru Road,
Kolkata-700 071, INDIA

Tel: 91 33-22267088/40060635 Fax: (91) 33-22266817

Ahmedabad Office/M³ Solution Center (Ahmedabad)

A-104 & A-105, First Floor, Solitaire Corporate Park, Near Divya Bhaskar Press, S.G. Road, Ahmedabad - 380 015, INDIA

TEL: (91) 079 - 29704902/903

Coimbatore Office

Regus, Srivari Srimath, 3rd Floor, Door No:1045, Avinashi Road, Coimbatore - 641 018,INDIA

TEL: (91) 9345005663

Taiwan**Mitutoyo Taiwan Co., Ltd. / M³ Solution Center Taipei**

4F., No.71, Zhouzi St., Neihu Dist.,Taipei City 114, TAIWAN (R.O.C.)

TEL:886(2)5573-5900 FAX:886(2)8752-3267

Taichung Branch / M³ Solution Center Taichung

1F., No. 299, Gaotie 1st Rd., Wuri Dist., Taichung City 414, TAIWAN (R.O.C.)

TEL:886(4)2338-6822 FAX:886(4)2338-6722

Kaohsiung Branch / M³ Solution Center Kaohsiung

1F., No.31-1, Haibian Rd., Lingya Dist., Kaohsiung City 802, TAIWAN (R.O.C.)

TEL:886(7)334-6168 FAX:886(7)334-6160

South Korea**Mitutoyo Korea Corporation****Head Office / M³ Solution Center**

(Sanbon-Dong, Geumjeong High View Build.), 6F, 153-8, Ls-Ro, Gunpo-Si, Gyeonggi-Do, 15808 KOREA

TEL:82(31)361-4200 FAX:82(31)361-4201

Busan Office / M³ Solution Center

(3150-3, Daejeo 2-dong) 8,Yutongdanji 1-ro 49beon-gil, Gangseo-gu, Busan, 46721 KOREA

TEL:82(51)324-0103 FAX:82(51)324-0104

Daegu Office / M³ Solution Center

(Galsan-dong, Daegu Business Center), 301-Ho, 217, Seongseongondan-ro, Dalseo-gu, Daegu 42704 KOREA

TEL:82(53)593-5602 FAX:82(53)593-5603

China**Mitutoyo Measuring Instruments (Shanghai) Co., Ltd.**

8th Floor, Tower 1 Lujiazui Jinkong Square No.1788/1800 Century Ave., Pudong New District, Shanghai 200122, CHINA

TEL:86(21)5836-0718 FAX:86(21)5836-0717

Suzhou Office / M³ Solution Center (Suzhou)

No. 46 Baiyu Road, Suzhou 215021, CHINA

TEL:86(512)6522-1790 FAX:86(512)6251-3420

Wuhan Office

Room 1701, Wuhan Wanda Center, No. 96, Linji-

ang Road, Wuchang District, Wuhan

Hubei 430060, CHINA

TEL:86(027)8544-8631 FAX:86(027)8544-6227

Chengdu Office

1-701, New Angle Plaza, 668# Jindong Road, Jinjiang District, Chengdu, Sichuan 610066,CHINA

TEL:86(28)8671-8936 FAX:86(28)8671-9086

Hangzhou Office

Room 804, Eastern International Business Center Building 1, No.600 Jinsha Road of

Hangzhou Economic and Technological Development Zone, 310018, CHINA

TEL: 86(571)8288-0319 FAX: 86(571)8288-0320

Tianjin Office / M³ Solution Center China (Tianjin)

Room D 12/F, TEDA Building, No.256 Jie-fang Nan Road Hexi District,Tianjin 300042, CHINA

TEL:86(22)5888-1700 FAX:86(22)5888-1701

Changchun Office

Room 815, 8F, Building A1, Upper East International No.3000 Dongsheng Street, Erdao District, Changchun, Jilin, 130031, CHINA

TEL:86(431)8192-6998 FAX:86(431)8192-6998

Chongqing Office

Room 1312, Building 3, Zhongyu Plaza, No.86, Hongjin Avenue,Longxi Street, Yubei District, Chongqing, 400000, CHINA

TEL:86(23)6595-9950 FAX:86(23)6595-9950

Qingdao Office

Room 638, 6F, No.192 Zhengyang Road, Chengyang District, Qingdao, Shandong, 266109, CHINA

TEL:86(532)8096-1936 FAX:86(532)8096-1937

Xi'an Office

Room 805, Xi'an International Trade Center, No. 196 Xiaozhai East Road, Xi'an, 710061, CHINA

TEL:86(29)8538-1380 FAX:86(29)8538-1381

Dalian Office

Room A-106 Shuijing SOHO, No.16 Harbin Road,Economic Development Zone,Dalian, 116600 CHINA

TEL:86(411)8718 1212 FAX:86(411)8754-7587

Zhengzhou Office

Room1801,18/F,Unit1,Building No.23, Shangwu Inner Ring Road, Zhengdong New District,Zhengzhou City, Henan Province, 450018,CHINA

TEL:86(371)6097-6436 FAX:86(371)6097-6981

Mitutoyo Leepport Metrology (Hong Kong) Limited

Room 818, 8/F, Vanta Industrial Centre, No.21-33, Tai Lin Pai Road, Kwai Chung, NT, HONG KONG

TEL:(852)2992-2088 FAX:(852)2670-2488

Mitutoyo Leepport Metrology (Dongguan) Limited / M³ Solution Center Dongguan

No.26, Guan Chang Road, Chong Tou Zone,
Chang An Town, Dong Guan, 523855 CHINA
TEL:86(769)8541 7715 FAX:86(769)-8541 7745

Mitutoyo Leepport Metrology (Dongguan) Limited – Fuzhou office

Room 2104, City Commercial Centre, No.129 Wu Yi Road N., Fuzhou City, Fujian Province, 350005 CHINA

TEL 86 (591) 8761 8095
FAX 86 (591) 8761 8096

Mitutoyo Leepport Metrology (Dongguan) Limited – Changsha office

Room 2207, Shiner International Plaza, No. 88, Kaiyuan Middle Road, Changsha City, Hunan Province, 410100 CHINA

TEL 86 (731) 8401 9276
FAX 86 (731) 8401 9376

Mitutoyo Leepport Metrology (Dongguan) Limited -Guangzhou Office

Room 605, Tower A, No. 264 Xing Tai Road, Shi Qiao Street, Pan Yu District, Guangzhou, Guangdong Province, 511400 CHINA

TEL:(86) 20-8466 1987 FAX:(86) 20-8466 1897

Mitutoyo Measuring Instruments (Suzhou) Co., Ltd.

No. 46 Baiyu Road, Suzhou 215021, CHINA
TEL:86(512)6252-2660 FAX:86(512)6252-2580

U.S.A.

Mitutoyo America Corporation

965 Corporate Blvd., Aurora, IL 60502, U.S.A.
TEL:1-(630)820-9666 Toll Free No. 1-888-648-8869
FAX:1-(630)978-3501

M³ Solution Center-Illinois

965 Corporate Blvd., Aurora, IL 60502, U.S.A.

M³ Solution Center-Ohio

6220 Hi-Tek Ct., Mason, OH 45040, U.S.A.
TEL:1-(888)-648-8869 FAX:1-(513)754-0718

M³ Solution Center-Michigan

46850 Magellan Drive, Suite 100 Novi, MI 48377, U.S.A.
TEL:1-(888)-648-8869 FAX: 1-(248)-926-0928

M³ Solution Center-California

16925 E. Gale Ave., City of Industry, CA 91745, U.S.A.
TEL:1-(888)-648-8869 FAX:1-(626)369-3352

M³ Solution Center-North Carolina

11515 Vanstory Dr., Suite 140, Huntersville, NC 28078, U.S.A.
TEL:1-(888)-648-8869 FAX:1-(704)875-9273

M³ Solution Center-Alabama

2100 Riverchase Center Suite 106, Birmingham, AL 35244, U.S.A
TEL:1-(888)-648-8869 FAX:1-(205)-988-3423

M³ Solution Center-Washington

1000 SW 34th St. Suite G, Renton, WA 98057 U.S.A.
TEL:1-(888)-648-8869

M³ Solution Center-Texas

4560 Kendrick Plaza Drive Suite 120 Houston, TX 77032, U.S.A.
TEL:1-(888)-648-8869 FAX:1-(281)227-0937

M³ Solution Center-Massachusetts

753 Forest Street, Suite 110, Marlborough, MA 01752, U.S.A.
TEL:1-(888)648-8869 FAX:1-(508)485-0782

Mitutoyo America Corporation Calibration Lab

965 Corporate Blvd., Aurora, IL 60502, U.S.A.
TEL:1-(888)-648-8869 FAX:1-(630)978-6477

Micro Encoder, Inc.

11533 NE 118th St., Kirkland, WA 98034-7111, U.S.A.
TEL:1-(425)821-3906 FAX:1-(425)821-3228

Micro Encoder Los Angeles, Inc.

16925 Gale Ave. City of Industry, CA 91745-1806 U.S.A.
TEL: 1-626-961-9661 FAX:1-626-333-8019

Mitutoyo America Corporation CT-Lab Chicago

965 Corporate Blvd., Aurora, IL 60502, U.S.A.
TEL: 1-(888)-648-8869 FAX: 1-(630)-820-3418

Canada

Mitutoyo Canada Inc.

2121 Meadowvale Blvd., Mississauga, Ont. L5N 5N1., CANADA
TEL:1-(905)821-1261 FAX:1-(905)821-4968

Montreal Office

7075 Place Robert-Joncas Suite 129, Montreal, Quebec H4M 2Z2, CANADA
TEL:1-(514)337-5994 FAX:1-(514)337-4498

Brazil

Mitutoyo Sul Americana Ltda.

Head office / M³ Solution Center / Factory
Rodovia Índio Tibiriçá 1555, CEP 08655-000 - Vila Sol Nascente - Suzano - SP - BRASIL
TEL:55 (11)5643-0040

Argentina

Mitutoyo Sul Americana Ltda.

Argentina Branch / M³ Solution Center

Av. B. Mitre 891/899 – C.P. (B1603CQI)
Vicente López –Pcia. Buenos Aires – ARGENTINA
TEL:54(11)4730-1433 FAX:54(11)4730-1411

Sucursal Cordoba / M³ Solution Center

Av. Amadeo Sabattini, 1296, esq. Madrid B°
Crisol Sur – CP 5000, Cordoba, ARGENTINA
TEL/FAX:54 (351) 456-6251

Mexico

Mitutoyo Mexicana, S.A. de C.V.

Industria Eléctrica No.15, Parque Industrial, Nau-
calpan de Juárez, Estado de México C.P.53370,
MÉXICO

TEL: 52 (01-55) 5312-5612
FAX: 52 (01-55) 5312-3380

Monterrey Office / M³ Solution Center

Blv. Interamericana No. 103, Parque Industrial
FINSA, C.P. 66636 Apodaca, N.L., MÉXICO
TEL: 52(01-81) 8398-8227/8228/8242/8244
FAX: 52(01-81) 8398-8226

Tijuana Office / M³ Solution Center

Calle José María Velazco 10501-C, Col. Cd. Industrial
Nueva Tijuana, C.P. 22500 Tijuana, B.C., MÉXICO
TEL: 52 (01-664) 647-5024

Querétaro Office / M³ Solution Center

Av. Cerro Blanco No.500-1, Colonia Centro Sur,
Querétaro, Querétaro, C.P. 76090, MÉXICO
TEL: 52 (01-442) 340-8018, 340-8019 and 340-8020
FAX: 52 (01-442) 340-8017

Mitutoyo Mexicana, S.A. de C.V. Querétaro Calibration Laboratory

Av. Cerro Blanco 500 30 Centro Sur,
Querétaro, Querétaro, C.P. 76090, MÉXICO
TEL: 52 (01-442) 340-8018, 340-8019 and 340-8020
FAX: 52 (01-442) 340-8017

Aguascalientes Office / M³ Solution Center

Av. Aguascalientes No. 622, Local 15 Centro Comer-
cial El Cilindro Fracc. Pulgas Pandas Norte, C.P.
20138, Aguascalientes, Ags. MÉXICO
TEL: 52 (01-449) 174-4140 and 174-4143

Irapuato Office / M³ Solution Center

Boulevard a Villas de Irapuato No. 1460 L.1 Col. Ejido
Irapuato C.P. 36643
Irapuato, Gto., MÉXICO
TEL: 52 (01-462) 144-1200 and 144-1400

Revision Record

Date of publication	Revision status	Details of revision
December 1, 2018	First edition	Publication
April 1, 2020	Revised first edition	Changes in orthography and expressions (no specification changes)

Mitutoyo Corporation

20-1, Sakado 1-Chome, Takatsu-ku, Kawasaki-shi, Kanagawa 213-8533, Japan
Tel: +81 (0)44 813-8230 Fax: +81 (0)44 813-8231
Home page: <https://www.mitutoyo.co.jp/global.html>

For the EU Directive, Authorized representative and importer in the EU:
Mitutoyo Europe GmbH
Borsigstrasse 8-10, 41469 Neuss, Germany

Printed in Japan

No. 99MAF600B