

# **ID-C112AX2**

**ABS Digimatic Indicator  
With Peak-value hold function**

## **User's Manual**

Read this User's Manual thoroughly  
before operating the instrument. After reading,  
retain it close at hand for future reference.

**Mitutoyo**

---

# CONVENTIONS USED IN THIS MANUAL

---

## Safety Precautions

To ensure that instruments are operated correctly and safely, Mitutoyo manuals use various safety symbols (Signal Words and Safety Alert Symbols) to identify and warn against hazards and potential accidents.

The following signs indicate **general** warnings:

---



Indicates a potentially hazardous situation which, if not avoided, could result in serious injury or death.

---



Indicates a potentially hazardous situation which, if not avoided, may result in minor or moderate injury or property damage.

---

## Types of Notes

The following types of **notes** are used in this manual to help the operator obtain reliable measurement data through correct instrument operation.

---

### IMPORTANT

An important note provides information essential to use the product. You cannot disregard this note.

An important note is a type of precaution, which if neglected could result in degraded performance or accuracy, or instrument malfunction/failure.

---

### NOTE

A note provides information to be especially noted or supplemented to use the product. A note also supplies information to be noted for specific operations.

---

### TIP

A *tip* is a type of note that helps the user apply the techniques and procedures described in the text to his or her specific needs.

It also provides reference information associated with the topic being discussed.

---

The specifications and information in this manual are subject to change without notice.

**Copyright © 2022-2023 Mitutoyo Corporation. All rights reserved.**

---

## Battery-related Warnings

---



### WARNING

- Always keep the battery out of the reach of infants and toddler to prevent it from being swallowed. If it is swallowed, consult a physician immediately.
  - The battery should never be short-circuit, disassembled or deformed, heated or exposed to flames.
  - If alkaline liquid contained in the battery does come in contact with your eyes, flush them immediately with plenty of clean water and consult a physician. If the liquid adheres to the skin or clothes, immediately flush it with plenty of clean water.
- 



### CAUTION

- Never charge the battery since it is a primary battery. Never reverse the positive and negative terminals when mounting. Improper handling of the battery could lead to leakage or explosion, causing bodily injury or malfunction.
- 

### NOTE

- Always use the recommended battery.
  - If the instrument will not be used for more than three months, remove the battery and store it separately.
  - When discarding or storing the battery, cover the positive (+) and negative (–) terminals with insulating tape to prevent contact with other metals. When disposing of it, follow the ordinances or regulations of the local government.
- 

## Disposal Warnings

---



### WARNING

- A liquid crystal display and a lithium metal battery are used in this product. When disposing of the instrument, follow the ordinances or regulations of the local government.
  - The liquid crystal display contains an irritating substance. Should the liquid content contact an eye or skin, flush with clean, flowing water. If the substance enters the mouth, immediately rinse the mouth, drink plenty of water, induce vomiting, and then consult a physician.
-

---

## Cautions on use

---

Observe the following precautions to avoid instrument failure or malfunction.

### **IMPORTANT**

- Do not strike the instrument or allow it to be struck.
- Do not drop it or apply excessive force to it.
- Do not disassemble or modify the instrument.
- Do not press the keys with a pointed object (such as screwdriver or ballpoint pen).
- Do not use or store the instrument under direct sunlight, or in an excessively hot or cold environment.
- Be alert for malfunction due to material deterioration if it is used in an environment with low or high atmospheric pressure.
- Do not store the instrument in a high-humidity environment. Do not use the instrument where it could be splashed with coolant.
- Do not use high-voltage equipment, such as an electric marking pen, near the instrument. Electronic parts may be damaged by such equipment. Be alert for malfunction if it is used in the vicinity of electric noise.
- Secure the instrument with a fixture such as a dial gage stand in a vibration-free environment.
- Do not subject the spindle to a vertical load or torsion.
- Wipe stains from the instrument panel by using a soft cloth or a cotton swab that is dry or moistened with diluted neutral detergent. Do not use an organic solvent such as thinner and benzene, which may cause the instrument panel to deform or malfunction.
- The contaminated spindle may cause malfunction. Wipe them off with a cloth damped with alcohol.

### **NOTE**

- Be alert for measurement errors caused by thermal expansion of the component parts and the fixtures, resulting from a significant temperature fluctuation. Use the instrument in a temperature-controlled room that has minimum temperature fluctuation. Allow sufficient time for the instrument to thermally stabilize if it is moved to an environment with a different temperature.

---

## Warranty

---

In the event that this product should prove defective in workmanship or material, within one year from the date of original purchase for use, it will be repaired or replaced, at Mitutoyo's option, free of charge upon its prepaid return to Mitutoyo

If the product fails or is damaged for any of the following reasons, it will be subject to a repair charge, even if it is still under warranty.

- (a) Failure or damage owing to fair wear and tear.
- (b) Failure or damage owing to inappropriate handling, maintenance or repair, or to unauthorized modification.
- (c) Failure or damage owing to transport, dropping, or relocation of the instrument after purchase.
- (d) Failure or damage owing to fire, salt, gas, abnormal voltage, lightning surge, or natural disaster.
- (e) Failure or damage owing to use in combination with hardware or software other than those designated or permitted by Mitutoyo.
- (f) Failure or damage owing to use in ultra-hazardous activities.

This warranty is effective only where the instrument is properly installed and operated in conformance with the instructions in this manual within the original country of the installation.

**EXCEPT AS SPECIFIED IN THIS WARRANTY, ALL EXPRESS OR IMPLIED CONDITIONS, REPRESENTATIONS, AND WARRANTIES OF ANY NATURE WHATSOEVER INCLUDING, WITHOUT LIMITATION, ANY IMPLIED WARRANTY OF MERCHANTABILITY, FITNESS FOR A PARTICULAR PURPOSE, NONINFRINGEMENT OR WARRANTY ARISING FROM A COURSE OF DEALING, USAGE, OR TRADE PRACTICE, ARE HEREBY EXCLUDED TO THE MAXIMUM EXTENT ALLOWED BY APPLICABLE LAW.**

You assume all responsibility for all results arising out of its selection of this product to achieve its intended results.

## Export Control Compliance

---

This Product falls into the Catch-All-Controlled Goods and/or Catch-All-Controlled Technologies (including Programs) under Category 16 of Appended Table 1 of Export Trade Control Order or under Category 16 of Appended Table of Foreign Exchange Control Order, based on Foreign Exchange and Foreign Trade Law of Japan.

If you intend re-exporting the product from a country other than Japan, re-selling the product in a country other than Japan, or re-providing the technology (including program), you shall observe the regulations of your country.

---

# Contents

---

CONVENTIONS USED IN THIS MANUAL.....	i
Battery-related Warnings.....	ii
Disposal Warnings.....	ii
Cautions on use.....	iii
Warranty.....	iv
Export Control Compliance.....	iv
<b>1 OVERVIEW.....</b>	<b>1-1</b>
1.1 Overview.....	1-1
1.2 Features(what you can do).....	1-2
1.3 Part Name and Dimensions.....	1-3
1.4 Details of the Display unit.....	1-4
1.5 Specifications.....	1-5
1.6 Standard accessories.....	1-6
1.7 Optional accessories.....	1-6
<b>2 SETUP.....</b>	<b>2-1</b>
2.1 Installation (replacement) of Battery and Initial Setting.....	2-1
2.2 Adjusting Display Angle.....	2-2
2.3 Securing Instrument.....	2-2
2.4 Mounting Lifting Lever.....	2-3
2.5 Mounting Lifting Knob.....	2-4
2.6 Mounting Lifting Release.....	2-5
2.7 Replacing Contact Point.....	2-5
<b>3 FUNCTIONS AND OPERATIONS.....</b>	<b>3-1</b>
3.1 Power ON/OFF.....	3-2
3.2 Measurement mode.....	3-2
3.2.1 Preset setting.....	3-2
3.2.2 Numerical value Editing.....	3-4
3.2.3 Switching measuring system (ABS/INC).....	3-6
3.2.4 Zero-setting display value.....	3-6
3.2.5 Changing to peak detection mode.....	3-7

---

3.2.5.1	Run-out detection mode "TIR" .....	3-8
3.2.5.2	Maximum value detection mode "Max".....	3-8
3.2.5.3	Minimum value detection mode "Min".....	3-8
<b>3.2.6</b>	<b>Holding display value (when a data processor is not connected).....</b>	<b>3-9</b>
<b>3.2.7</b>	<b>Display value output (when a data processor is connected).....</b>	<b>3-10</b>
<b>3.2.8</b>	<b>Switching the counting direction.....</b>	<b>3-10</b>
<b>3.2.9</b>	<b>Centering pointer of analog bar .....</b>	<b>3-10</b>
<b>3.2.10</b>	<b>Swtching units (in/mm) .....</b>	<b>3-10</b>
<b>3.3</b>	<b>Setup mode .....</b>	<b>3-11</b>
3.3.1	TOL:Tolerance judgment.....	3-14
3.3.2	RES:Resolution .....	3-16
3.3.3	CALC:Calculation function .....	3-18
3.3.4	SCALE:Analog bar graduation .....	3-20
3.3.5	LOCK:Key-lock.....	3-22
3.3.6	OTHER:Other functions .....	3-24
3.3.6.1	PC(1):PC communication .....	3-27
3.3.6.2	RULER(2):Analog bar display .....	3-30
3.3.6.3	FAST(3):FAST mode .....	3-32
3.3.6.4	RESET(4):All reset .....	3-34
<b>3.4</b>	<b>Calibration mode .....</b>	<b>3-36</b>
<b>4</b>	<b>DATA OUTPUT.....</b>	<b>4-1</b>
4.1	Cable connection.....	4-1
4.2	Output connector.....	4-2
4.3	Output Data Format.....	4-2
4.4	Timing Chart.....	4-3
<b>5</b>	<b>ERROR MESSAGE AND ACTION .....</b>	<b>5-1</b>

Service Network

# 1

## OVERVIEW

This chapter describes overview of this instrument including names and functions of each part, external dimensions, and details of the display unit.

### 1.1 Overview

Measurement and Setup mode are available with this instrument.

- Measurement mode
  - Normal mode : Dynamically displays measurement data
  - Peak detection mode :
    - Run-out detection mode: Detects run-out of the measurement data
    - Maximum value detection mode: Detects maximum value of the measurement data
    - Minimum value detection mode: Detects minimum value of the measurement data
- Setup mode: Enables each setting

There are two measuring systems, ABS (Preset) system and INC (Comparison) system in measurement mode.

- Measuring system
  - ABS system: Absolute value measurement which measures distance (displacement) from a preset position .
  - INC system: Comparative measurement which measures distance (displacement) from the zero-set position .



---

## 1.2 Features (what you can do)

---

The following can be achieved with this instrument:

- Measurement-related items
  - Tolerance judgment of the measurement result P.3-14
  - Measurement in the absolute system P.3-6
  - Measurement of distance from the reference point (Comparative measurement) P.3-6
  - Measurement of run-out P.3-8
  - Measurement of maximum value P.3-8
  - Measurement of minimum value P.3-8
  - Outputting the measurement data to the data processor P.3-10
  - Switching the display value unit P.3-10
- Display-related settings
  - Changing the resolution P.3-16
  - Changing the graduation of the analog bar P.3-20
  - Hiding the analog bar P.3-30
  - Switching the counting direction P.3-10
  - Holding the displayed measurement data P.3-9
  - Setting up the center point of the analog bar as the current value P.3-10
- Other setting-related items
  - Key lock P.3-22
  - Setting up each function from PC P.3-27
  - Setting up the FAST mode P.3-32
  - Resetting to the factory default P.3-34

## 1.3 Part Names and Dimensions

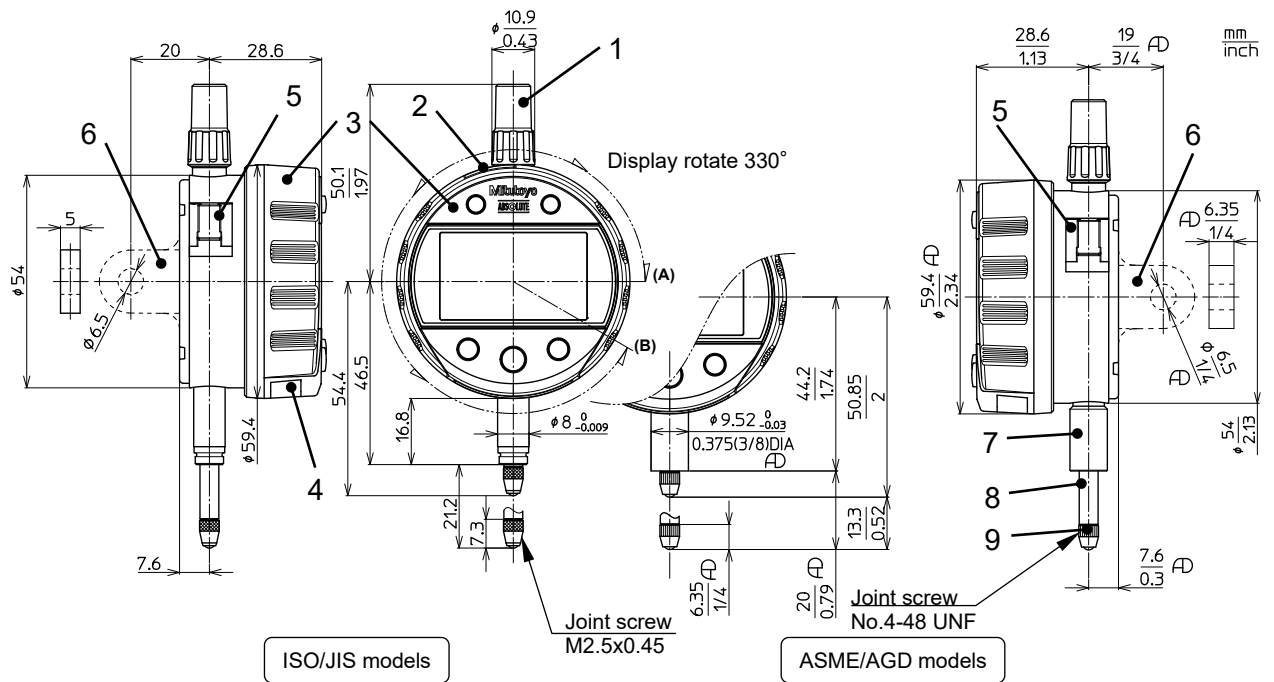

1	Cap
2	Output connector (with rubber cap)
3	Display unit
4	Battery holder
5	Lever mounting position (left and right)
6	Back
7	Stem
8	Spindle
9	Contact point
	ISO/JIS models : Part No.901312
	ASME/AGD models : Part No.21BZB005

# 1.4 Details of the Display unit

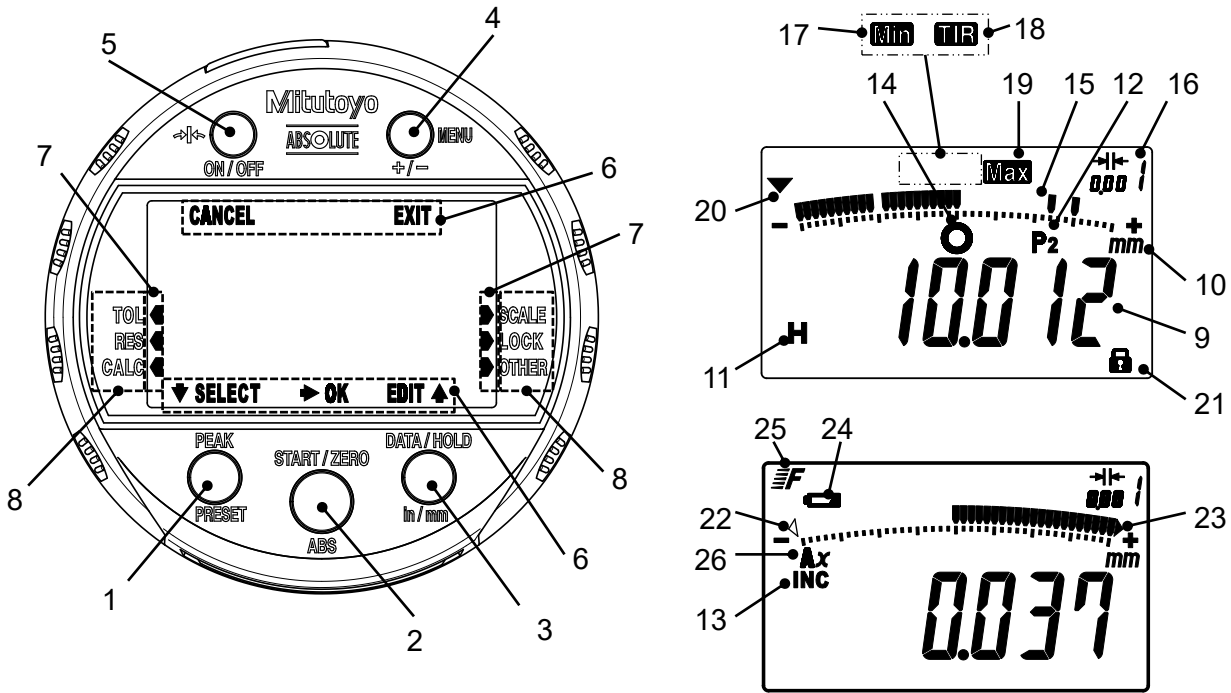

1	Lower left key	11	Data hold	21	Lock
2	Center key	12	Preset No.	22	Lower over-range
3	Lower right key	13	Comparative measurement	23	Upper over-range
4	Upper right key	14	Tolerance judgment	24	Low battery alarm
5	Upper left key	15	Analog bar	25	FAST
6	Key assist	16	Analog bar graduation	26	Calculation formula
7	Cursor	17	Minimum value detection measurement		
8	Parameter	18	Run-out detection measurement		
9	Display value	19	Maximum value detection measurement		
10	Unit	20	Reverse direction measurement		

## 1.5 Specifications

Model name *1		ID-C112AX2	ID-C112AXB2	ID-C112AMX2	ID-C112AMXB2	ID-C112AEX2	ID-C112AEXB2
Order No. *1		543-300-10	543-300B-10	543-301-10	543-301B-10	543-302-10	543-302B-10
Resolution *2		0.001/0.01 mm		0.00005/0.0001/0.0005 in // 0.001/0.01 mm			
Measuring range		12.7 mm		0.5 in / 12.7 mm			
ISO/JIS	Error of indication (MPE)	Partial measuring range $P_{MPE}$ *3	0.003 mm		0.003 mm		
		Total measuring range $E_{MPE}$ *3	0.003 mm		0.003 mm		
	Hysteresis $H_{MPE}$ *3	0.003 mm		0.003 mm			
	Repeatability $R_{MPE}$ *3	0.002 mm		0.002 mm			
ASME	Overall *3*4	-		±0.0001 in			
	Hysteresis *3	-		0.0001 in			
	Repeatability *3	-		0.0001 in			
Stem diameter		φ 8 mm				0.375 in DIA	
Contact point		Carbide (M2.5x0.45)				Carbide (No.4-48UNF)	
Measuring force (MPL)		≤1.5 N					
Measuring direction		Useful in all directions					
Protection level *5		IP42 (in factory shipment state)					
Power supply		Lithium battery CR2032 × 1pc.					
Battery life *6		Normal use: Approx. 1 year					
Scale		Electrostatic capacitance absolute encoder					
Response speed		Infinite					
Measurement frequency *7		Normal mode: 10 times/s Peak detection mode: 50 times/s					
CE marking/ UKCA marking		EMC Directive/Electromagnetic Compatibility Regulations: EN IEC 61326-1 Immunity test requirement: Clause 6.2 Table 2 Emission limit: Class B RoHS Directive/The Restriction of the Use of Certain Hazardous Substances in Electrical and Electronic Equipment Regulations: EN IEC 63000					
Operating temperature		0 °C~40 °C					
Storage temperature		-10 °C~60 °C					
Back type		With lug	Flat	With lug	Flat	With lug	Flat
Net weight		180 g	170 g	180 g	170 g	195 g	170 g

\*1 : The flat back models have a suffix 'B' to the Order Numbers. Or with-center-lug back model have not one.

\*2 : Changeable by way of setting. Refer to "3.3.2 RES : Resolution".

\*3 : 20°C, normal measurement.

The values are calculated with coefficients; A=1 and the resolution set to 0.001 mm. They are subject to change depending on the coefficient settings.

\*4 : Overall magnification and linearity.

\*5 : The protection level (IP: International Protection) is indicated according to IEC 60529 and JIS C 0920 standards.

\*6 : Battery life depends on use of the indicator. Use the above value as a guide.

\*7 : If the spindle speed exceeds following, the correct peak value may not be displayed.

Normal mode, Peak detection mode: 10µm/s

Peak detection mode: 50µm/s

---

## 1.6 Standard accessories

---

- — Lithium battery CR2032 (for monitor)
- No. 99MAH061B User's Manual
- No. 99MAH036B Quick Reference Manual
- No. 99MAH042M Product regulation manual
- — Certificate of inspection
- No. WA100 Warranty

## 1.7 Optional accessories

---

- No. 905338 Connecting cable (1m)
- No. 905409 Connecting cable (2m)
- No. 21EZA313 Parameter Setup Kit
- No. 21EZA198 Lifting lever
- No. 21EZA105 Lifting knob
- No. 21JZA295 Lifting release
- Interchangeable contact points and extension rods for Mitutoyo dial indicators
- Color caps for Mitutoyo dial indicators (waterproof type)

# 2

## SETUP

This chapter describes installation of a battery, how to mount the stand or jigs, and the accessory replacement procedure.

### 2.1 Installation (replacement) of Battery and Initial Setting

A lithium battery (CR2032) is used with this instrument.

This instrument is not delivered with the battery set into position, so set the battery before use.

1. Remove the battery holder by using a flat-blade screwdriver or the like. (When replacing the battery, remove the spent battery.)
2. Set the battery into the battery holder as described in the figure below.
3. Set the battery holder into the original position. ([-----] is displayed.)
4. To enter into the preset setting, press the center key.
5. Set up the preset values referring to "3.2.1 Preset setting".
6. Set up measurement mode and function which you want. (See section 3. Functions and Operating Procedure.)

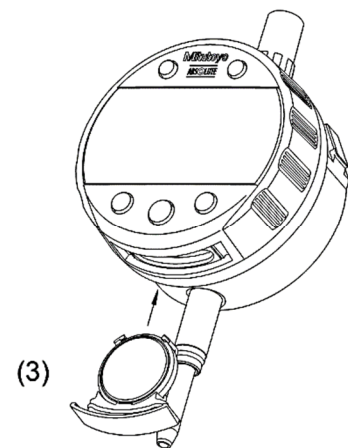
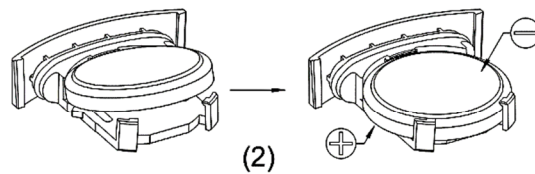

---

**IMPORTANT**

- Do not use a sharp-pointed tool to remove the battery holder and not pry out the battery holder, to prevent damage to the battery holder.
  - Note not to damage your nail when the battery holder is removed by hand.
  - If the battery and battery holder is not set properly, a damage and malfunction may result.
  - If the Measurement mode is not entered after executing the above procedure, set the battery again.
  - If the instrument will not be used for more than three months, remove the battery and store it separately to prevent damage by battery leakage.
- 

**NOTES**

- The supplied battery is used only to check the functions and performance of the instrument, so it may not meet the battery life specification.
- 

## 2.2 Adjusting Display Angle

---

The display can be rotated 90° (to position A) clockwise or 240° (to position B) counterclockwise from the initial position. (For the rotating range, see 1. Part Names and Dimensions.)

**IMPORTANT**

- Stoppers are set at both positions A and B. Stop rotating the display at the stoppers, or the instrument may malfunction.
  - Do not push in the display or pull it out. Doing so may cause the instrument to malfunction.
- 

## 2.3 Securing Instrument

---

Secure the instrument to a stand, or fix it with a fixture or jig, when using it.

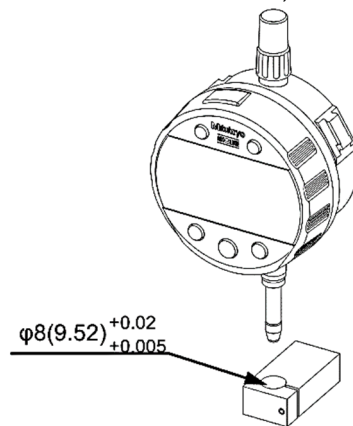

---

**IMPORTANT**

- Avoid using a lock screw to fix the stem directly. If fixed under a clamping torque of 150 N·cm or greater, the spindle may not move smoothly.
- 

**NOTES**

- Set up the instrument with the spindle perpendicular to the reference plane or the surface to be measured. If the spindle axis is not perpendicular to the reference plane (measured surface), measurement errors will result.

→If the spindle axis is inclined  $\phi$  from the perpendicular line to the reference plane, measurement error  $\delta$  will be as follows for the measured length of 12 mm:

$$\phi = 1^\circ: \delta = 0.002\text{mm}$$

$$\phi = 2^\circ: \delta = 0.007\text{mm}$$

$$\phi = 3^\circ: \delta = 0.016\text{mm}$$

- If the instrument is to be secured with a fixture, fix it by the stem in a slotted hole of about  $\phi 8\text{G7}$  (+0.005 to +0.02) or  $\phi 9.52$  (+0.005 to +0.02).
- 

## 2.4 Mounting Lifting Lever

---

A lifting lever (optional/ Parts No. 21EZA198) is available for this instrument.

1. Rotate the cap counterclockwise to remove it from the instrument.
2. Hold the spindle with pliers protecting it with a rag to prevent it from rotating, remove the screw at the top of the spindle.
3. Attach the spindle stop provided with the lifting lever. Next, fix the lifting lever to the lever mounting part (dovetail) while applying its top to the spindle stop.

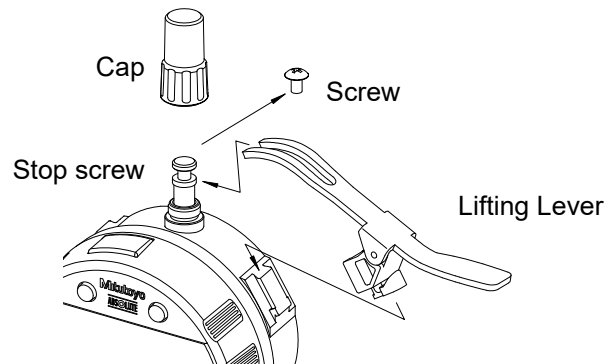
**IMPORTANT**

- Store the removed screw and cap, taking care to prevent loss.
  - Using this instrument with the spindle stop loose may damage the internal parts or workpiece.
  - When the spindle stop is not mounted, be sure to attach the removed screw to the top of the spindle. Failure to do so may damage the internal parts or workpiece.
-



---

## 2.5 Mounting Lifting Knob

---

A lifting knob (optional/ Parts No. 21EZA105) is available.

1. Rotate the cap counterclockwise to remove it from the instrument.
2. Hold the spindle with pliers while protecting it with a rag to prevent rotation, remove the screw at the top of the spindle.
3. Fix the lifting knob to the top of the spindle.

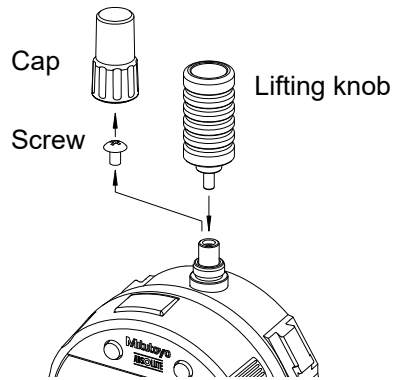

---

### IMPORTANT

- Store the removed screw and cap, taking care to prevent loss.
  - Using this instrument with the lifting knob loose may damage the internal parts or workpiece.
  - When the lifting knob is not mounted, be sure to attach the removed screw to the top of the spindle. Failure to do so may damage the internal parts or workpiece.
-

---

## 2.6 Mounting Lifting Release

---

A release (optional/Parts No.21JZA295) is available.

1. After removing the cap, remove the screw.
2. Mount the mounting plate on the spindle. (Please use the removed screw)
3. Attach the release to the mounting plate.

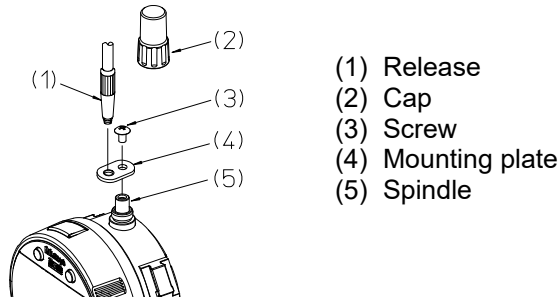

- 
- IMPORTANT**
- If you insert something other than the release or apply excessive force, it may break down.
  - If the spindle is moved up and down with the release loose, internal parts may be damaged.
- 

## 2.7 Replacing Contact Point

---

Interchangeable contact points and extension rods for Mitutoyo dial indicators are available.

1. Use two pliers (One is for holding the spindle and the other is for holding the contact point.) and a rag in the figure below. Rotate the plier which is holding the contact point clockwise to remove the contact point.
2. In a similar way, rotate the plier which is holding a contact point or an extension rod counterclockwise to mount.

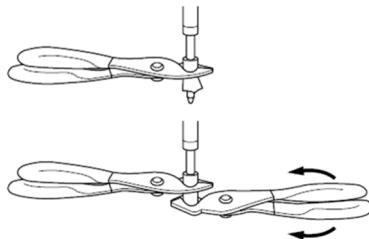

- 
- IMPORTANT**
- When replacing the contact point hold the spindle and turn the contact point. Otherwise, the indicator may be damaged.
  - Changing the contact point also may change the external dimensions, measuring force, and limitation of the measuring direction. Contact point errors such as the non-perpendicularity of a flat contact point and run-out of the roller point add to the measurement error.
-

---

MEMO

# 3

## FUNCTIONS AND OPERATIONS

This chapter describes functions and their operations of this instrument.

Each key function will change as follows depending on the operation mode.

- Measurement mode

\* "Press and hold" means pressing and holding the key for 2 seconds or more.

Keys	Press	Press and hold
Lower left	PEAK (3.2.5)	PRESET (3.2.1)
Center	START (3.2.5) ZERO (3.2.4)	ABS (3.2.3)
Lower right	DATA (3.2.7) HOLD (3.2.6)	in/mm (3.2.10)
Upper left	→← (3.2.9)	ON/OFF (3.1)
Upper right	MENU (3.3)	+/- (3.2.8)

- Setup mode/Numerical values setting

Keys	Press	Press and hold
Lower left	<b>SELECT</b> / ▼	—
Center	<b>OK</b> / ►	—
Lower right	<b>EDIT</b> / ▲	—
Upper left	<b>CANCEL</b>	—
Upper right	<b>EXIT</b>	—

---

## 3.1 Power ON/OFF

---

Power ON: Press the upper left key.

Power OFF: Press and hold the upper left key

---

### NOTE

- If the power is turned off right after the battery is installed before completing preset setting, "-----" will be displayed when the power is turned on again.
  - When the power is turned off while the instrument is holding the display value, and then the power is turned on again, the held display value will be released.
- 

Auto-off function (energy saving function): The power automatically will be turned off after approximately 20 minutes of idle time.

---

### NOTE

- When enabling FAST mode, auto-off function will be disabled. (Refer to "3.3.6.3 FAST(3): FAST mode".)
- 

## 3.2 Measurement mode

---

The following describes each setting and operation of the measurement mode of this instrument. Refer to "1.1 Overview" for details of the measurement mode.

### 3.2.1 Preset setting

Set up the preset when performing master setting.

Three settings; P1, P2, P3 are available as preset values.

1. Starting the preset setting  
Press and hold the lower left key in the measurement mode. "P□" (□ indicates Preset No.) starts blinking and the previously set value will be displayed. If the value does not need to be changed, skip to step 4.
2. Selecting preset No.  
Press the lower left key and select the preset No. to be set. Pressing the lower left key, the display changes in the following order: P1→P2→P3.
3. Editing the preset value.  
Press the lower right key to move the numerical value editing. Refer to "3.2.2 Numerical value editing" for details of the setting.
4. Completing the preset setting  
Lift up the spindle and position the contact point in the desired preset position. Next, press the center key. The preset setting is completed and the measurement in the ABS system will be ready.  
In the peak detection mode, the spindle position of maximum or minimum value will be set as the preset position.

## IMPORTANT

- Repeatability in the range of 0.2 mm (.0079") from the bottom of the stroke is not guaranteed for this indicator. When setting the origin, be sure to lift the spindle at least 0.2 mm (.0079") from the bottom of the stroke.
- The preset value will be calculated automatically according to the unit or the resolution. Check the preset value when the resolution is changed since the conversion error may occur.

## NOTE

- Press the upper left key to cancel the setting.
- The preset setting cannot be completed while the spindle is moving. So complete it after the spindle stops.
- The setup preset values and position will be held after the power is turned off. However, when the battery is replaced, the preset position will be cleared. Set up the position again.
- The power supply cannot be turned off with the upper left key in the preset setting.
- When auto-off is activated during preset setting, the setting will be canceled.
- The preset setting cannot be completed if Overflow error of preset value (Err95) is occurring for the selected preset number. Reset the preset value.
- A rubber damper has been attached to the spindle in this indicator as a shock absorber. The elasticity of the damper may cause the indicated value to not stabilize at the bottom of the stroke, but this will not cause any operational problems. Also, the spindle may feel heavy at the bottom of the stroke when this indicator is first used, but this can be resolved by pushing the spindle up once.

### Preset setting (Master setting)

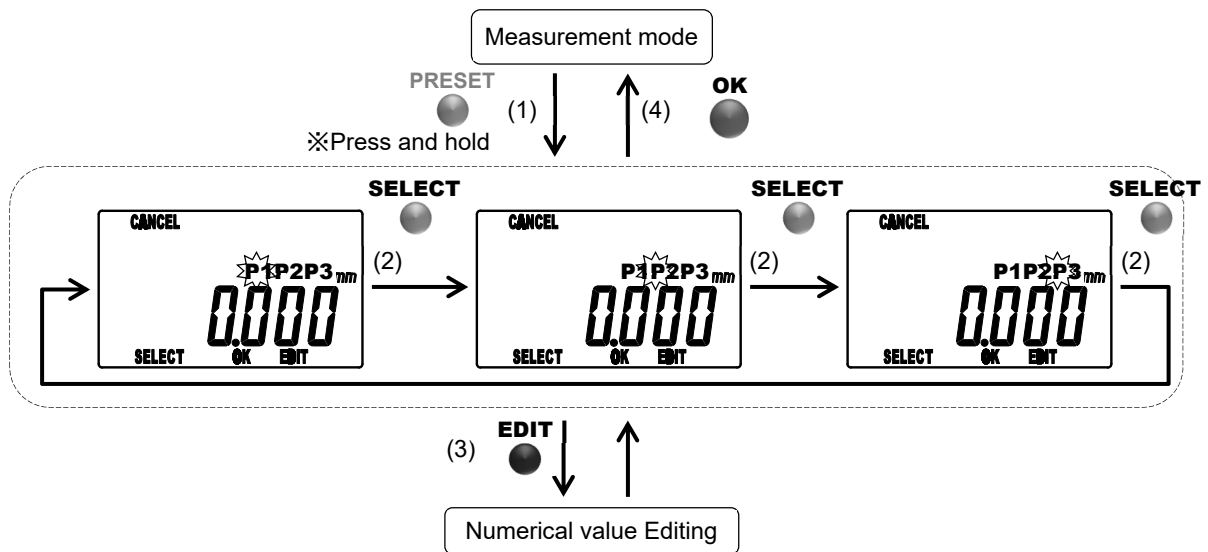

---

### 3.2.2 Numerical value Editing

Numerical value for "Preset", "Tolerance judgment", "Calculation" can be edit by same key operation.

Items that requires numerical value editing

Functions	Editing items
Preset	P1, P2, P3
Tolerance judgment	Upper limit, Lower limit
Calculation function	Calculation coefficient: A

- Moving signs (+/-) and digits  
Press the center key to move the sign or digit.
- Changing signs (+/-) and numerical values  
Press the lower left key or lower right key to change the sign (+/-) or numerical value.

For signs (+/-)

Press the lower left or lower right key to switch the signs "+"  $\leftrightarrow$  "-".

For numerical values

Pressing the lower left key, the display changes in the following order:

0→9→8→... →1→0.

Pressing the lower right key, the display changes in the following order:

0→1→2→... →9→0.

- Completing the numerical value editing  
Press the upper right key to complete the numerical value editing.  
After editing the numerical values, the previous setup widow will be restored.

---

**NOTE**

- If the last digit of resolution is "5", that of the numerical value changes in the order of "0→5→0".
- Press the upper left key to cancel the setting.
- The value is temporarily saved until completing each setting before moving the numerical value editing. If canceled, it will be deleted.

---

**Numerical value Editing**

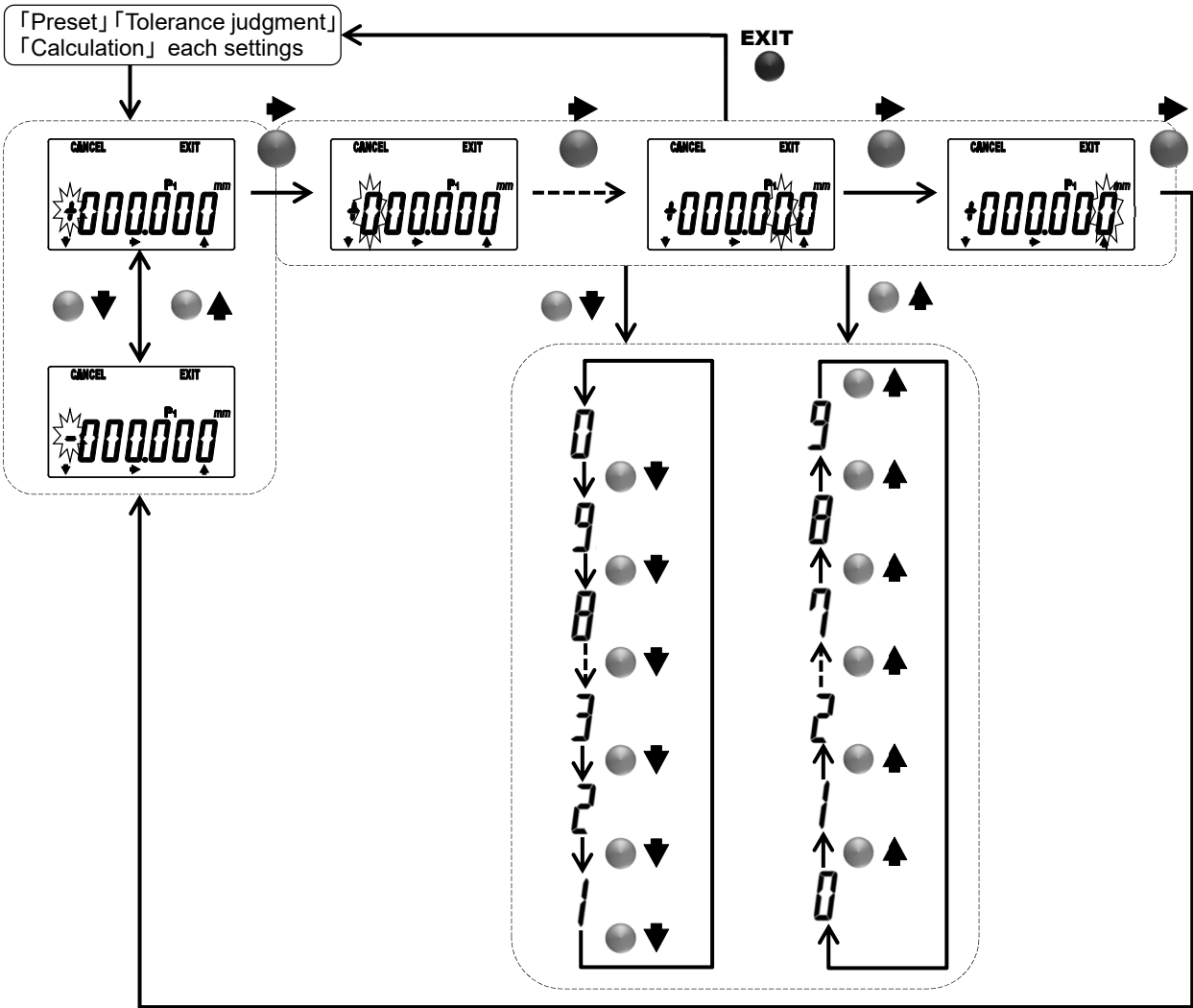



### 3.2.3 Switching measuring system (ABS/INC)

This can be operated only in the normal mode, not in the peak detection mode.  
Press the center key to switch from ABS to INC.

Press and hold the center key to switch from INC to ABS.

#### NOTE

- When the system is switched from ABS to INC, also display value will be set to the zero.
- It cannot switch from ABS to INC while the spindle is moving. So switch from ABS to INC after stopping the spindle.
- If switching is required in the peak detection mode, press the lower left key a few times to change the mode to the normal, and then switch the system.

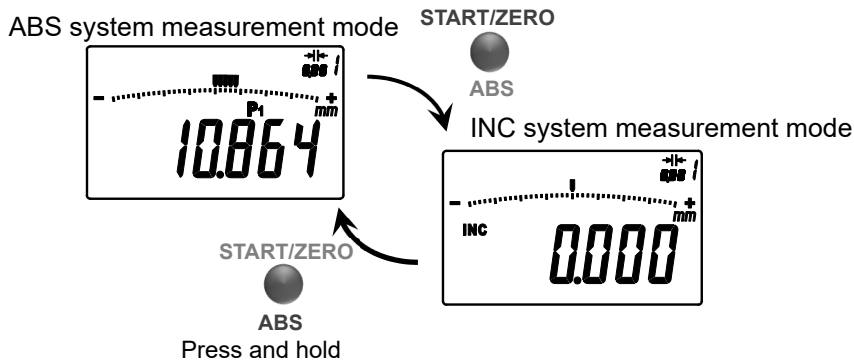

### 3.2.4 Zero-setting display value

Press the center key in the normal mode, the display value is set to zero.

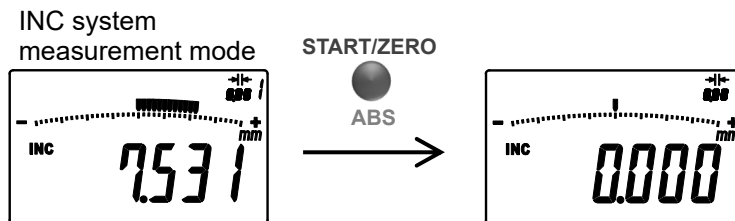

#### NOTE

- It cannot set to zero while the spindle is moving. So set to zero after stopping the spindle.

### 3.2.5 Changing to peak detection mode

Press the lower left key to switch the mode between the normal mode and peak detection mode.

Pressing the lower left key to check each peak value by changing the display "TIR", "Max", and "Min" while the run-out, maximum and minimum value are held.

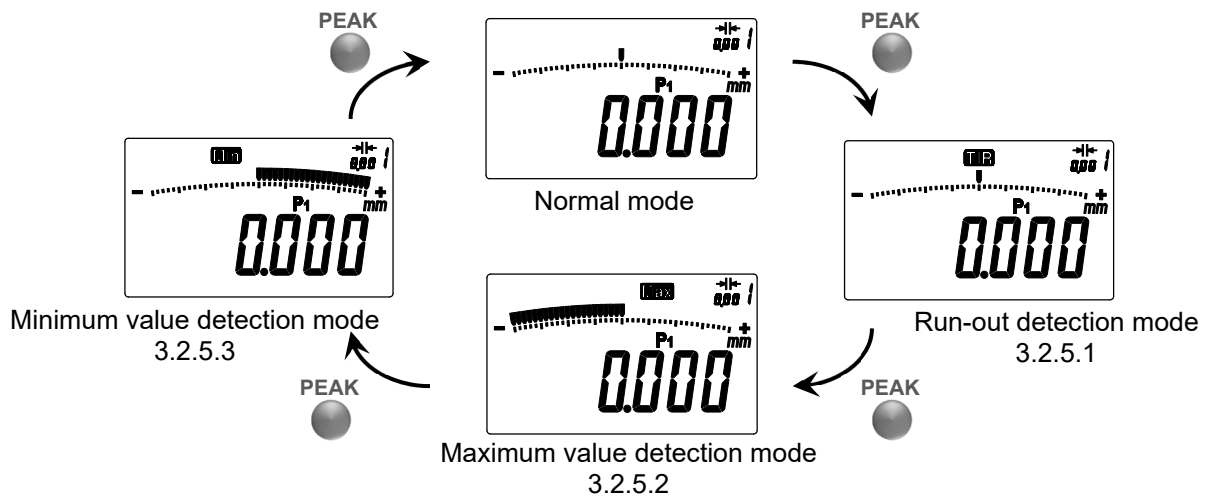

- NOTE**
- In the peak detection mode, start measuring while the contact point is contacting the measuring target.
  - Note that the displacement caused by vibration, impact, etc. is detected.
  - Detecting the peak will be being continued until changing to the normal mode.
  - Holding the display value is possible in the peak detection mode. (Refer to "3.2.6 Holding display value".)
  - The run-out, maximum value and minimum value can be confirmed to change the operation mode during holding the display value.
  - The operation mode cannot be changed from peak detection to the normal mode while the display value is held.

---

### 3.2.5.1 Run-out detection mode "TIR"

Hold the run-out of fluctuating measurement data (maximum value - minimum value). When the tolerance judgment condition has been set, the instrument displays the result of tolerance judgment for the run-out.

1. Press the lower left key a few times until "TIR" is displayed.
2. Press the center key. Run-out detection measurement is started.
3. When the measurement data exceeds either the maximum or minimum value, the display value will be updated.  
During update, "Max" or "Min" will blink.
4. The detected run-out will be held until the center key is pressed next time. Press the center key to restart run-out measurement.

#### NOTE

- When either a maximum or minimum value pointer of the analog bar is out of displayable range, the analog bar graduation automatically change by selection the "Auto".
  - The tolerance judgment in the run-out detection mode is made by comparing the actual run-out value with the tolerance value (upper limit - lower limit).
- 

### 3.2.5.2 Maximum value detection mode "Max"

Hold the maximum value of fluctuating measurement data. When the tolerance judgment condition has been set, the instrument displays the result of tolerance judgment for the maximum value.

1. Press the lower left key a few times until "Max" is displayed.
2. Press the center key. Maximum value detection measurement is started.
3. When the measurement data exceeds the maximum value, "Max" starts blinking and the value is updated.
4. The detected maximum value will be held until the center key is pressed next time.  
Press the center key to restart maximum value measurement.

#### NOTE

- The maximum point can be edited into a desired value. So this instrument can measure based on this point. Refer to "3.2.1 Preset setting" to set the preset.
  - When a maximum value pointer of the analog bar is out of displayable range, the pointer automatically moves to the center.
- 

### 3.2.5.3 Minimum value detection mode "Min"

Hold the minimum value of fluctuating measurement data. When the tolerance judgment condition has been set, the instrument displays the result of tolerance judgment for the minimum value.

1. Press the lower left key a few times until "Min" is displayed.
2. Press the center key. Minimum value detection measurement is started.
3. When the measurement data falls below the minimum value, "Min" starts blinking and the value is updated.
4. The detected minimum value will be held until the center key is pressed next time.  
Press the center key to restart minimum value measurement.

**NOTE**

- The minimum point can be edited into a desired value. So this instrument can measure based on this point. Refer to "3.2.1 Preset setting" to set the preset.
- When a minimum value pointer of the analog bar is out of displayable range, the pointer automatically moves to the center.

**TIP**

- The following describes examples of display value and tolerance judgment in each measurement mode.

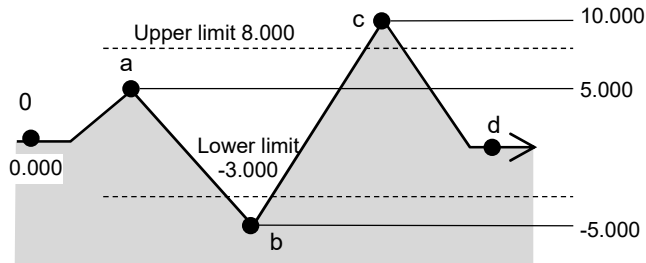

Example of display value in each measurement mode

	0	→	a	→	b	→	c	→	d
Normal	0.000	↗	5.000	↘	-5.000	↗	10.000	↘	0.000
TIR	0.000	↗	5.000	↗	10.000	↗	15.000		
Max	0.000	↗	5.000			↗	10.000		
Min	0.000			↘	-5.000				

Example of tolerance judgment (upper limit 8.000, Lower limit-3.000)

	0	a	b	c	d
Normal	○		◀	▶	○
TIR		○		◀ ▶	
Max		○		▶	
Min	○			◀	

**3.2.6 Holding display value (when a data processor is not connected)**

Press the lower right key in the measurement mode. "H" is displayed and the display value will be held. Press the lower right key again to release the hold.

**NOTE**

- If a data processor is connecting to this instrument during "H" is displayed, the held value will be output to it and then be released.
- The spindle position is being detected while "H" is displayed.

---

### 3.2.7 Display value output (when a data processor is connected)

The display value can be output to the data processor.

Press the lower right key in the measurement mode to output the display value to the data processor.

Refer to "4 Data Output" for cable connections, pin assignment, output format, and timing chart.

#### NOTE

- To use the data output function properly, refer to the operation manual of the data processor to be connected.
  - When inputting a data output request (REQ) from a data processor, the spindle must be stopped. Otherwise, this instrument may output wrong data or may not output.
  - If this instrument receives data output request (REQ) signals repeatedly at short intervals, it may not output a data.
- 

### 3.2.8 Switching the counting direction

Set the counting direction against the spindle moving direction.

Press and hold the upper right key in normal mode. When the direction is switched to reverse(-), this indicator counts down by pushing up the spindle, and "▼" is displayed.

#### NOTE

- The preset position will not be changed by the counting direction switching.
- 

### 3.2.9 Centering pointer of analog bar

When the pointer of the analog bar is out of displayable range, move the pointer to the center by setting up the graduation of the bar. It is same as in the case of mechanical dial indicator, shifting the bezel to a desired scale position.

Press the upper left key in each measurement mode in order to center the pointer of analog bar.

- Normal mode : Current measuring position
  - Run-out detection mode : Center of the run-out
  - Tolerance judgment mode : Center of the tolerance value, when enabling the tolerance judgment function
  - Maximum value detection mode : Maximum value
  - Minimum value detection mode : Minimum value
- 

#### NOTE

- It cannot center the pointer of analog bar when enabling the tolerance judgment function except Run-out detection mode. Because the instrument gives priority to display the upper/lower limits.
- 

### 3.2.10 Switching units (in/mm)

Press and hold the lower right key to switch the display unit between inch and metric.

#### NOTE

- When the unit is switched, the following will be converted accordingly: display value, preset values, tolerance value, resolution, and analog bar graduation. If it causes the overflow error of display value (Err 30), set the proper resolution. Also, it causes overflow error of each setting values or conversion error, it is recommended to check the values of each setting after switching unit.
  - The display unit can be switched only in the normal mode. So if switching is required in the peak detection mode, press the lower left key a few times to change the mode to the normal, and then switch.
-

---

## 3.3 Setup Mode

---



The following parameters can be checked or set in the setup mode.

- Starting up the setup mode  
Press the upper right key in the measurement mode to move into the setup mode.
- Selecting parameters
  1. The blinking cursor indicates the currently selected parameter.
  2. Press the lower left or lower right key to display the current set parameter.
    - Pressing the lower left key, the cursor moves in the following order: TOL→RES→ ... →OTHER→TOL.
    - Pressing the lower right key, the cursor moves in the following order: TOL→OTHER→ ... →RES→TOL.
  3. Press the center key to move the parameter setting
- Completing the setup mode  
Press the upper right key to complete setup mode and return to the measurement mode,

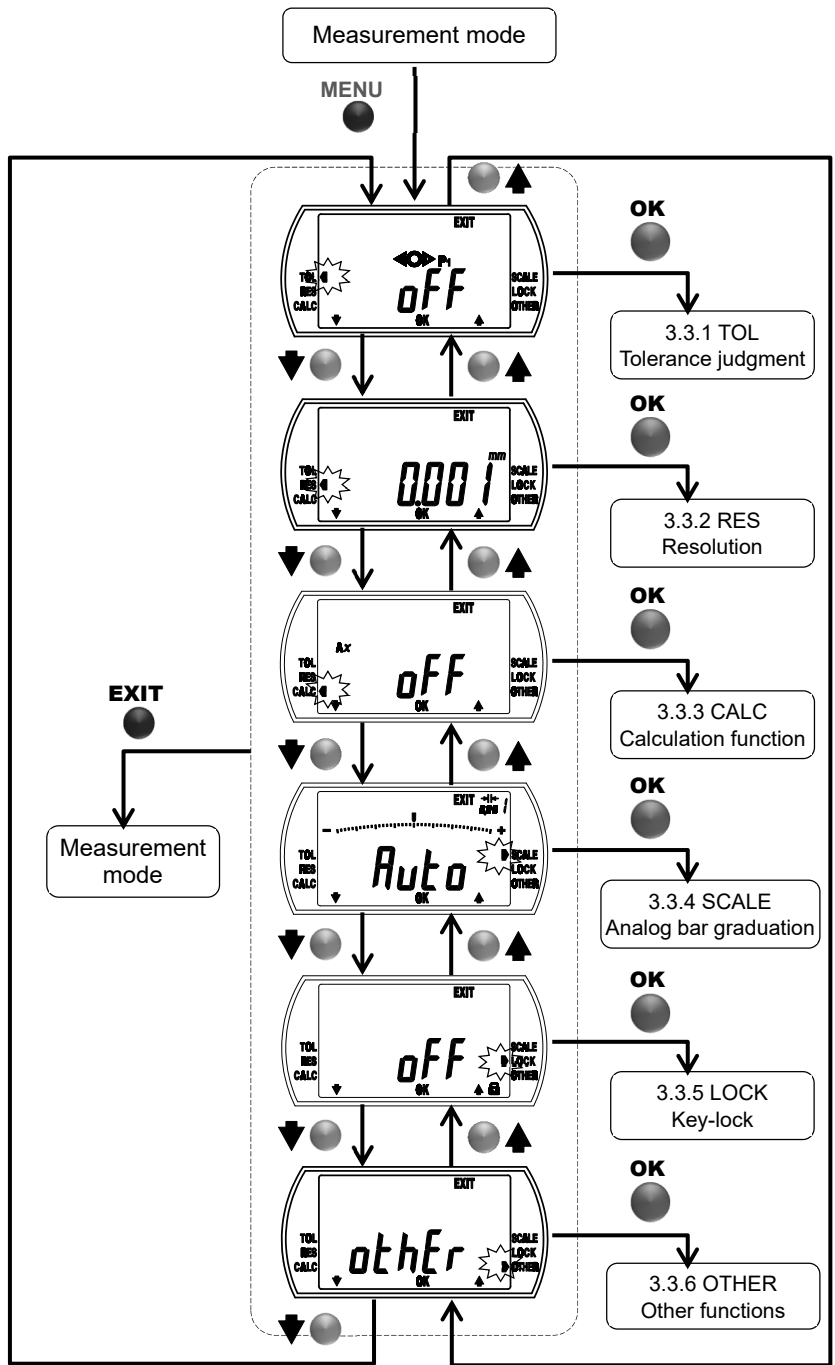
- 
- NOTE**
- During the setup mode, key assists which correspond to each key will be displayed. (Refer to "1.4 Details of Display Unit".)
  - The setup parameters will be registered even after the battery is replaced or power is turned off. However, if the battery is replaced while the key-lock function is enabled, the key-lock function will be set off.
  - The power supply cannot be turned off with the upper left key in the setup mode.
  - IF the power is turned off by Auto-off function until completing each settings, the set parameter will be deleted.
-

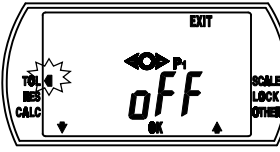
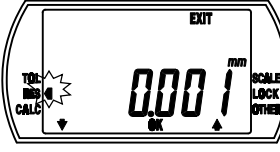
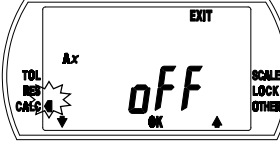
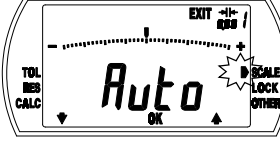

Parameters

Parameter	Example of display	Settings
<p>TOL (Tolerance judgment)</p>	 <p>The LCD display shows the word "OFF" in large characters. At the top right is "EXIT", at the bottom center is "OK", and at the bottom right is "SCALE LOCK OTHER". On the left side, there are labels "TOL", "RES", and "CALC" with arrows pointing to the left. A starburst icon is next to the "TOL" label.</p> <p>"ON" or "OFF"</p>	<p>Selecting ON/OFF of tolerance judgment and tolerance value setting</p>
<p>RES (Resolution)</p>	 <p>The LCD display shows the number "0.001" followed by a vertical bar and "mm". At the top right is "EXIT", at the bottom center is "OK", and at the bottom right is "SCALE LOCK OTHER". On the left side, there are labels "TOL", "RES", and "CALC" with arrows pointing to the left. A starburst icon is next to the "RES" label.</p> <p>Current resolution</p>	<p>Selecting resolution of the display</p>
<p>CALC (Calculation function)</p>	 <p>The LCD display shows the word "OFF" in large characters. At the top right is "EXIT", at the bottom center is "OK", and at the bottom right is "SCALE LOCK OTHER". On the left side, there are labels "TOL", "RES", and "CALC" with arrows pointing to the left. A starburst icon is next to the "CALC" label.</p> <p>"ON" or "OFF"</p>	<p>Selecting ON/OFF of calculation function and coefficients setting</p>
<p>SCALE (Analog bar graduation)</p>	 <p>The LCD display shows the word "Auto" in large characters. At the top right is "EXIT", at the bottom center is "OK", and at the bottom right is "SCALE LOCK OTHER". On the left side, there are labels "TOL", "RES", and "CALC" with arrows pointing to the left. A starburst icon is next to the "SCALE" label. Above the "Auto" text, there is a horizontal line with a dotted pattern and a vertical bar on the right.</p> <p>Current analog bar graduation</p>	<p>Selecting analog bar graduation</p>
<p>LOCK (Key-lock)</p>	 <p>The LCD display shows the word "OFF" in large characters. At the top right is "EXIT", at the bottom center is "OK", and at the bottom right is "SCALE LOCK OTHER". On the left side, there are labels "TOL", "RES", and "CALC" with arrows pointing to the left. A starburst icon is next to the "LOCK" label.</p> <p>"ON" or "OFF"</p>	<p>Selecting ON/OFF of key-lock function</p>
<p>OTHER (Other functions)</p>	 <p>The LCD display shows the word "other" in large characters. At the top right is "EXIT", at the bottom center is "OK", and at the bottom right is "SCALE LOCK OTHER". On the left side, there are labels "TOL", "RES", and "CALC" with arrows pointing to the left. A starburst icon is next to the "OTHER" label.</p> <p>"other"</p>	<p>Setting other functions (Refer to "3.3.6 OTHER: Other functions".)</p>



---

### 3.3.1 TOL: Tolerance judgment

The tolerance judgment function compares measurement data (display value) with tolerance values (upper/lower limit) for OK/NG judgment. The tolerance values can be set in ABS system (P1, P2, P3) and INC system respectively.

- Enabling tolerance judgment. Changing tolerance values
  1. Press the upper right key in the measurement mode to move the setup mode.
  2. Press the lower left or lower right key to move the blinking cursor to "TOL".
  3. Press the center key to move the ON/OFF selection of the tolerance judgment function.
  4. Press the lower left key to select "ON".
  5. Press the center key to move the tolerance value setting (upper/lower limit). The upper limit sign is blinking, and currently set value will be displayed.
  6. When press the lower left key, the display switches to the lower limit. (Pressing the lower left key, the upper limit and the lower limit switch.) The lower limit sign (or the upper limit sign) is blinking, and the currently set lower limit (or the upper limit) will be displayed.
  7. To edit the tolerance value, select the target value and press the lower right key. The numerical value editing will be enabled. (Refer to "3.2.2 Numerical value editing".)
  8. Press the center key after checking or editing the tolerance values. The tolerance judgment is set "ON", and the mode returns to the parameter setting. (Refer to "3.3 Setup Mode".)
- Disabling tolerance judgment
  1. Press the upper right key in the measurement mode to move the setup mode.
  2. Press the lower left or lower right key to move the blinking cursor to "TOL".
  3. Press the center key to move the ON/OFF selection of the tolerance judgment function.
  4. Press the lower left key to select "OFF".
  5. Press the center key to set the tolerance judgment "OFF" and return to the parameter setting. (Refer to "3.3 Setup Mode".)

#### IMPORTANT

- The tolerance values will be set in the currently active system (ABS (P1, P2, P3) or INC). Check the desired measuring system is selected before setting the tolerance judgment function.
- The tolerance values will be calculated automatically according to the unit or the resolution. Check the tolerance values after the resolution is changed since the conversion error may occur.

#### NOTE

- Press the upper left key to cancel the operation.
- The tolerance judgment in the run-out detection mode is made by comparing the actual run-out value with the tolerance value (upper limit - lower limit).
- If the upper limit is set lower than the lower limit, the tolerance upper/lower limit setting error (Err 90) will occur. Reset the values to be the upper limit is greater than the lower limit.
- The tolerance judgment setting cannot be completed if Overflow error of upper / lower limit value (Err95) is occurring. Reset the upper or lower limit value.

**Enabling tolerance judgment. Changing tolerance values**

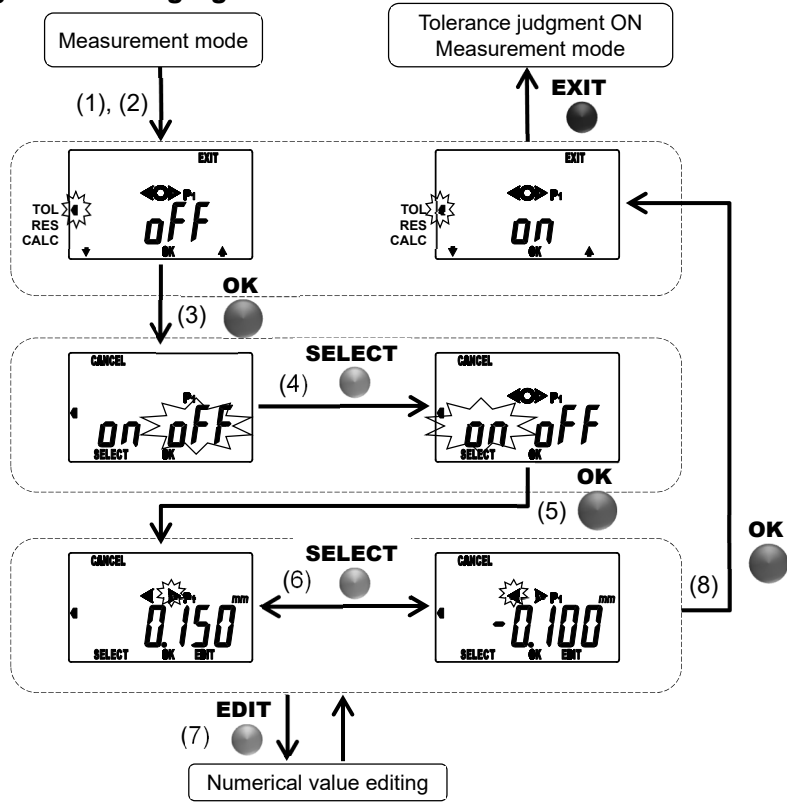

**Disabling tolerance judgment**

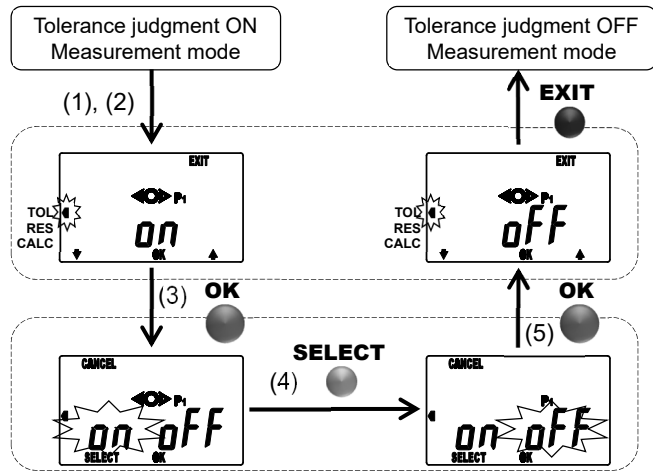

---

### 3.3.2 RES: Resolution

The resolution of the display can be changed.

- Selecting the resolution

1. Press the upper right key in the measurement mode to move the setup mode.
2. Press the lower left or lower right key to move the blinking cursor to "RES".
3. Press the center key to set the resolution.
4. Press the lower left or lower right key to switch the resolution.
5. Press the center key to set the resolution and the mode returns to the parameter setting. (Refer to "3.3 Setup Mode".)

---

**IMPORTANT** · The preset values (P1, P2, P3) and the tolerance values (upper and lower limits) will be calculated automatically according to the resolution. Check the values after changing the resolution, since the conversion error or overflow error (Err95) may occur.

---

**NOTE** · Press the upper left key to cancel the operation.  
· When the unit is switched, the resolution will be automatically changed accordingly. Check the resolution after switching the unit.

---

## Selecting the resolution

Metric models

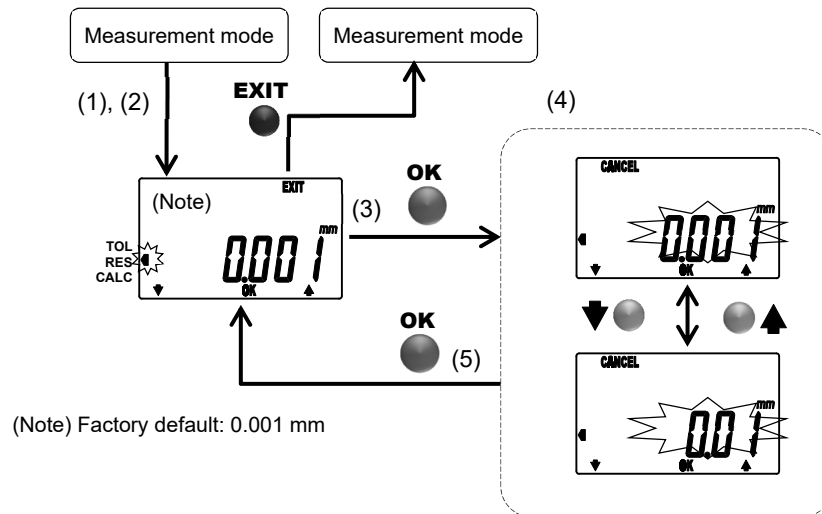

Inch models

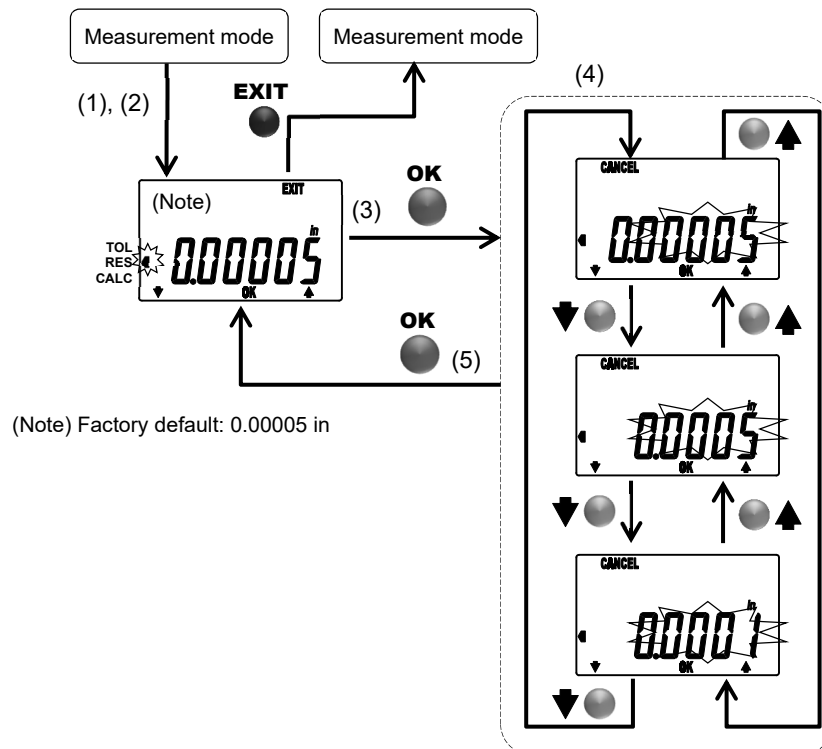

---

### 3.3.3 CALC: Calculation function

This special instrument supports measurements by internal calculations using the formula  $f(x)=Ax$  ("x" is a spindle displacement). The calculation coefficient A can be set.

- Enabling the calculation function. Checking or changing the calculation coefficient.
  1. Press the upper right key in the measurement mode to move the setup mode.
  2. Press the lower left or lower right key to move the blinking cursor to "CALC".
  3. Press the center key to move the ON/OFF selection of the calculation function.
  4. Press the lower left key to select "ON".
  5. Press the center key to move the calculation coefficient setting
  6. Press the lower right key, to move the numerical value editing. (Refer to "3.2.2 Numerical value editing".)
  7. Press the center key after checking or changing the calculation coefficient. The calculation function is set "ON", and the mode returns to the parameter setting. (Refer to "3.3 Setup Mode".)
- Disabling the calculation function
  1. Press the upper right key in the measurement mode to move the setup mode.
  2. Press the lower left or lower right key to move the blinking cursor to "CALC".
  3. Press the center key to move the ON/OFF selection of the calculation function.
  4. Press the lower left key to select "OFF".
  5. Press the center key to set the calculation function "OFF" and return to the parameter setting. (Refer to "3.3 Setup Mode".)

---

**IMPORTANT** · When enabling the calculation function or changing the calculation coefficient in the ABS system, the preset position will be cleared. However the preset value can be called, as it is being registered.

---

**NOTE** · Press the upper left key to cancel the operation.  
· Overflow error of display value (Err30) may occur as a result of calculation. (Refer to "5 ERROR MESSAGES AND ACTION".)  
· The factory default of the calculation coefficients are A=1.  
· The calculation function setting cannot be completed if the calculation coefficient A is set to zero. Reset the calculation coefficient A.  
· The calculation coefficient A will not be converted by the resolution changing.  
· The number of digits available for the calculation coefficient A is described right table.

---

**Enabling the calculation function. Checking or changing the calculation coefficients.**

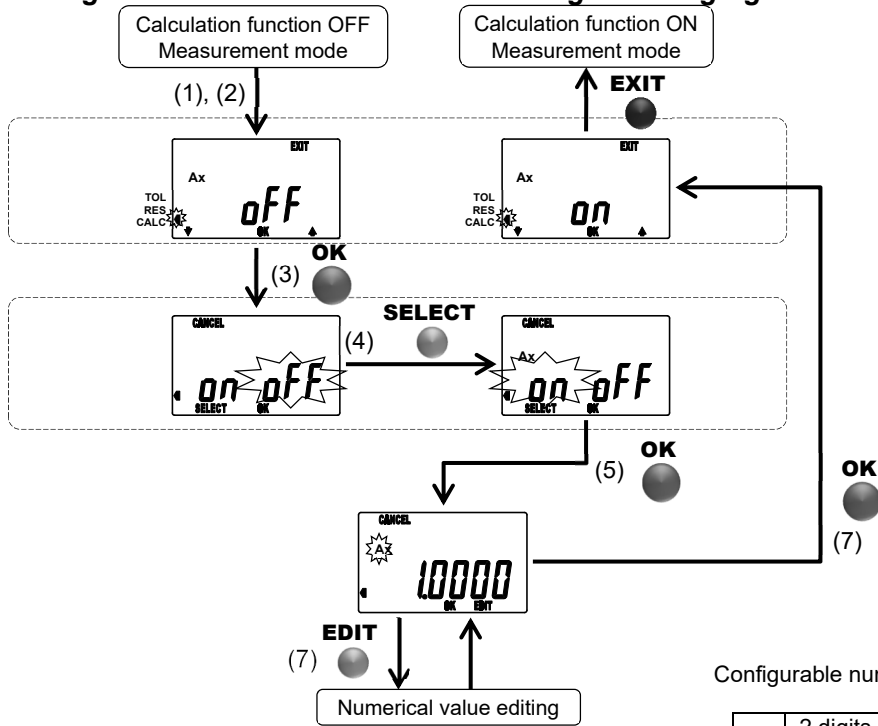

Configurable number of digits for calculation coefficient

A	2 digits before the decimal point, 4 digits after the decimal point
---	--

**Disabling the calculation function**

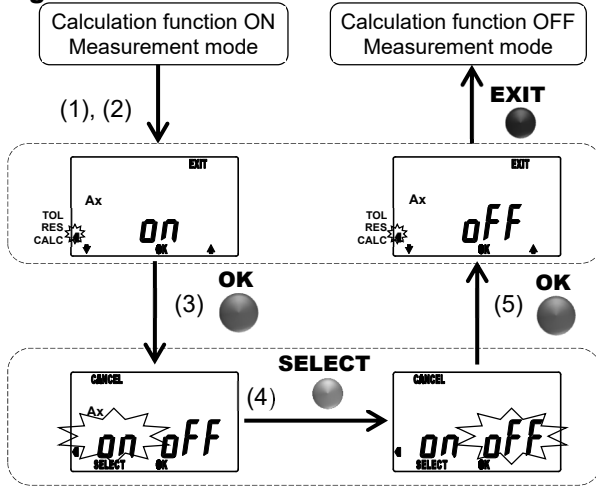

---

### 3.3.4 SCALE: Analog bar graduation

The analog bar graduation (Display range:  $\pm 20$ ) can be changed.

- Selecting a graduation of analog bar
  1. Press the upper right key in the measurement mode to move the setup mode.
  2. Press the lower left or lower right key to move the blinking cursor to "SCALE".
  3. Press the center key to set the analog bar graduation.
  4. Press the lower left or lower right key to switch the analog bar graduation.
  5. Press the center key to set the analog bar graduation and return to the parameter setting. (Refer to "3.3 Setup Mode".)

- 
- NOTE**
- Press the upper left key to cancel the operation.
  - The factory default of the analog bar graduation is "Auto". Change it as required.
  - The analog bar will be displayed based on the display value. If the analog bar graduation is selected lower than the resolution of display value, the analog bar will vary discontinuously.
  - When the unit is switched, the graduation of the analog bar will be automatically changed accordingly. After switching the unit, check the graduation of the analog bar.

- 
- TIP**
- The graduation of the analog bar will change automatically in the following conditions:
    1. Run-out detection mode: Graduation will change run-out to be within the display range.
    2. Tolerance judgment ON: Graduation will change tolerance values to be within the display range.
    3. Changing resolution: Graduation will change same as resolution.
-

## Selecting a graduation of analog bar

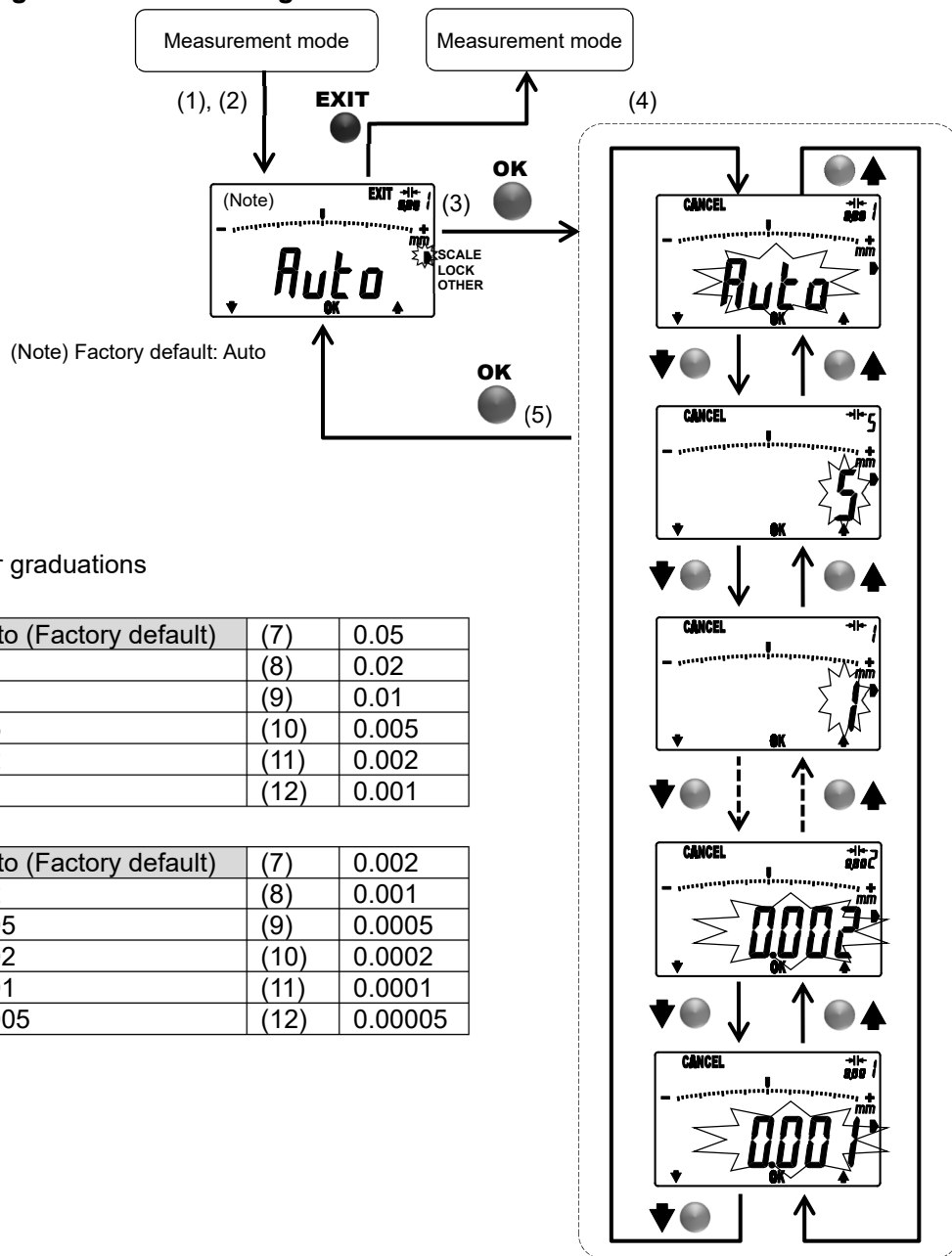



### 3.3.5 LOCK: Key-lock

Key operation can be partially disabled in order to avoid incorrect key operation.

- Enabling key-lock (disabling key operation)
  1. Press the upper right key in the measurement mode to move the setup mode.
  2. Press the lower left or lower right key to move the blinking cursor to "LOCK".
  3. Press the center key to move the ON/OFF selection of the key-lock function.
  4. Press the lower left key to select "ON".
  5. Press the center key to set the key-lock function "ON" and return to the parameter setting. (Refer to "3.3 Setup Mode".)
- Disabling key-lock (enabling key operation)
  1. Press the upper right key in the measurement mode to move the setup mode.
  2. Press the lower left or lower right key to move the blinking cursor to "LOCK".
  3. Press the center key to move the ON/OFF selection of the key-lock function.
  4. Press the lower left key to select "OFF".
  5. Press the center key to set the key-lock function "OFF" and return to the parameter setting. (Refer to "3.3 Setup Mode".)

- NOTE**
- Press the upper left key to cancel the operation.
  - The key-lock function will not be disabled by turning off the power. However, it will be set off when the battery is replaced.
  - When the key-lock is set on, other than key-lock cannot be selected in the setup mode.
  - The key-lock items can be customized via PC communication. (Refer to "3.3.6.1 PC(1): PC communication".)

Functions to be disabled while key-lock is on

- Measurement mode

Keys	Operation	Key names		Disabled functions		Remarks
		Metric model	Inch models	Metric model	Inch models	
Lower left key	Press	PEAK		○		3.2.5
	Press and Hold	PRESET		○		3.2.1
Center key	Press	ZERO		○		3.2.4
	Press and Hold	ABS		○		3.2.3
Lower right key	Press	DATA/HOLD		—		3.2.6 3.2.7
	Press and Hold	—	in/mm	—	○	3.2.10
Upper left key	Press			○		3.2.9
	Press and Hold	ON/OFF		—		3.1
Upper right key	Press	MENU		—		3.3
	Press and Hold	+/-		○		3.2.8

**Enabling key-lock (disabling key operation)**

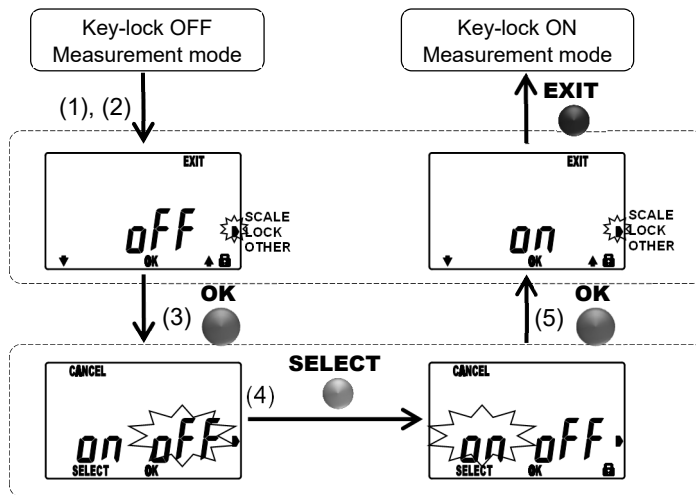

**Disabling key-lock (enabling key operation)**

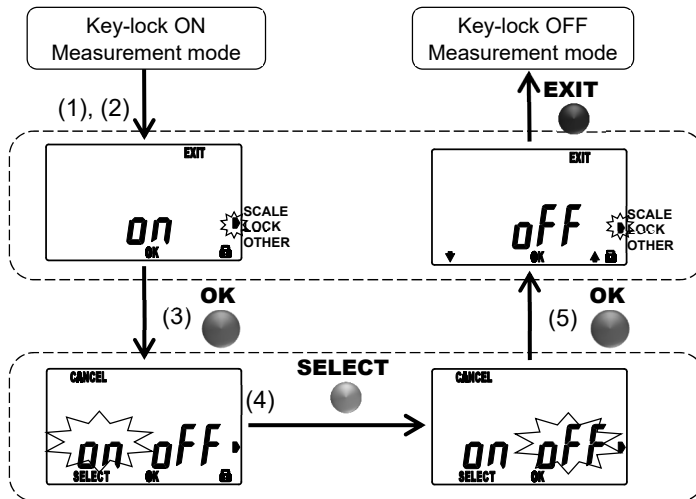

---

### 3.3.6 OTHER: Other functions

Check or set up the PC communication or the unit display.

- Selecting items available in OTHER functions

1. Press the upper right key in the measurement mode to move the setup mode.
2. Press the lower left or lower right key to move the blinking cursor to "OTHER".
3. Press the center key to move the ON/OFF selection of OTHER functions.
4. Press the lower left or lower right key to change the item in the other functions.
  - Pressing the lower left key, the display changes in the following order:  
PC communication → Analog bar display →...→ All reset → PC communication
  - Pressing the lower right key, the display changes in the following order:  
PC communication → All reset→...→ Analog bar display → PC communication
5. Press the center key to return to the parameter setting.



---

**NOTE** · Press the upper left key to cancel the operation.

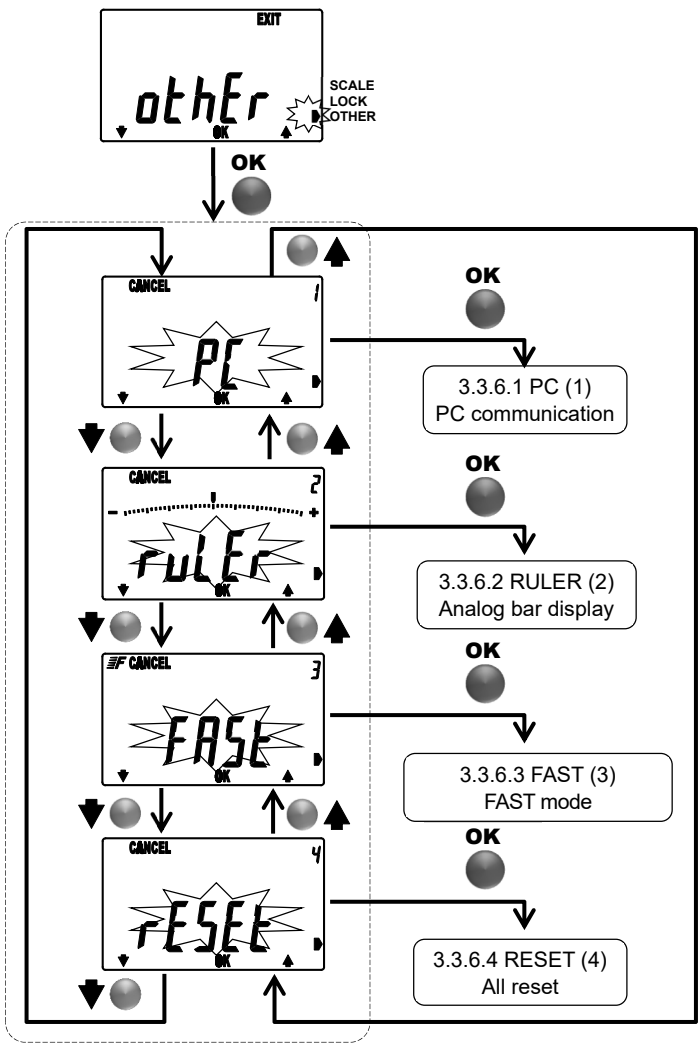
---

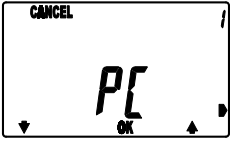
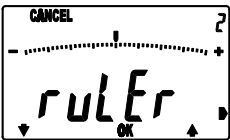

Items available in OTHERs

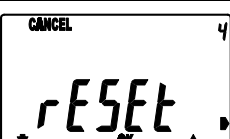
Other functions (Item No.)	Example of LCD display	Settings
PC(1) PC communication	 <p>1, PC</p>	Selecting ON/OFF of PC communication for each setting
RULER(2) Analog bar display	 <p>2, RULER</p>	Selecting ON/OFF of analog bar display
FAST(3) FAST mode	 <p>3, FAST</p>	Selecting ON/OFF of FAST mode
RESET(4) All reset	 <p>4, RESET</p>	Executing all reset

---

### 3.3.6.1 PC(1): PC communication

This instrument can set up or change various items with special software, if it connects to Personal computer with a Parameter setup kit (optional accessory).

- Enabling PC communication

1. Connect a Parameter setup kit.
2. Press the upper right key in the measurement mode to move the setup mode, and select OTHER functions. (Refer to "3.3.6 OTHER: Other functions".)
3. Press the lower left or lower right key until "PC" is blinking.
4. Press the center key to move the PC communication setting.
5. Press the lower left key to select "ON".
6. Press the center key to start communication with the PC.  
When the communication is started, "PC con" will be displayed.

- 
- NOTE**
- Press the upper left key to cancel the communication with the PC.
  - Remove the cap of the output connector, and securely connect the cable.
  - Do not disconnect the Parameter setup kit while communicating with the PC.
  - When communication with PC is finished, the measurement mode will be restored.
  - For details of communication with the PC, refer to the operation manual supplied with the Parameter setup kit.
- 

#### Enabling PC communication

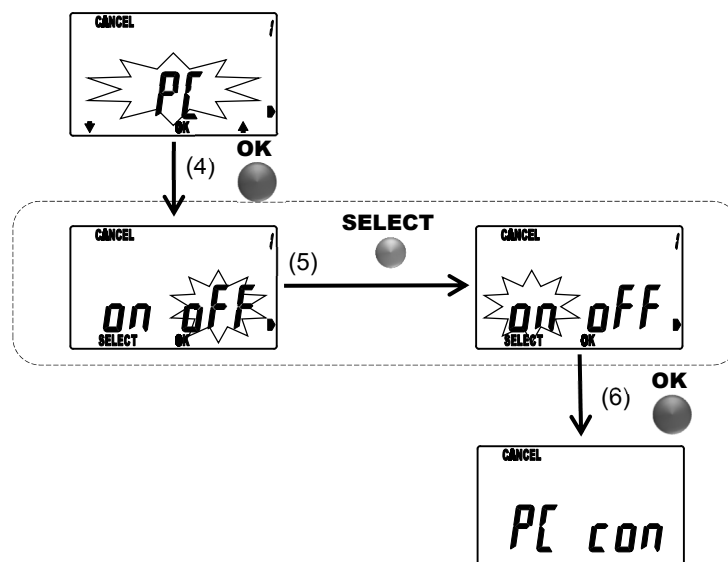

Configurable items by external input

Configurable items		Settings
Preset		Preset No.: P1 / P2 / P3 Preset value: P1 / P2 / P3
Measuring system		ABS system / INC system
Counting direction		Plus/minus (When pushed the spindle)
Unit		mm / in (only inch models)
Peak detection mode		OFF/ Run-out detection mode/ Maximum value detection mode/ Minimum value detection mode
Tolerance judgment		ON / OFF Upper and lower limit of each measuring system (ABS (P1, P2, P3) and INC)
Resolution	Metric	0.001 / 0.01
	Inch	0.00005 / 0.0001 / 0.0005
Calculation function		ON / OFF Calculation coefficient: A
Analog bar graduation	Metric	AUTO / 0.001 / 0.002 / 0.005 / 0.01 / 0.02 / 0.05 / 0.1 / 0.2 / 0.5 / 1 / 5
	Inch	AUTO / 0.00005 / 0.0001 / 0.0002 / 0.0005 / 0.001 / 0.002 / 0.005 / 0.01 / 0.02 / 0.05 / 0.2
Key-lock		ON / OFF Key-lock setting (multiple selection possible) <ul style="list-style-type: none"> <li>• PEAK (Changing the peak detection mode)</li> <li>• PRESET(Preset setting)</li> <li>• ZERO (Zero-set of display value)</li> <li>• ABS (Switching the measuring system)</li> <li>• DATA/HOLD (Holding the display value/Display value output)</li> <li>• in/mm (Switching the unit (inch↔mm))</li> <li>• → ← (Centering the analog bar)</li> <li>• +/- (Switching the counting direction)</li> </ul>
Analog bar display		ON / OFF
FAST mode		ON / OFF
Parameter-lock		ON / OFF Parameter-lock setting (multiple selection possible) <ul style="list-style-type: none"> <li>• Preset value setting: P1/ P2/ P3</li> <li>• Tolerance setting: P1: upper limit/lower limit P2: upper limit/lower limit P3: upper limit/ lower limit INC: upper limit, lower limit</li> <li>• Calculation coefficient setting: A</li> <li>• MENU key</li> </ul>

---

**TIP**

- The parameter-lock function is to disable each setting and all reset operation, and it is available only while communicating with PC.
  - When the parameter lock is enabled, the locked parameter cannot be edited with the instrument.
  - While the parameter lock is enabled, the "EDIT" sign with the lower right key will not be displayed.
  - When the MENU Key is set to "Lock", the parameters other than PC communication cannot be confirmed and set by operating the key of this instrument. Release the Lock of MENU Key by conducting the PC communication if you want to confirm or set each parameter.
- 

Display example during parameter-lock (Preset setting)

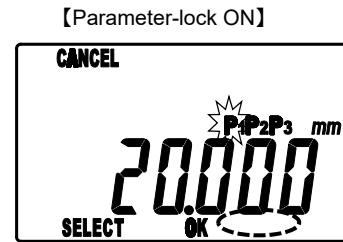
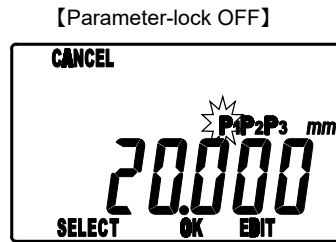

※The "EDIT" sign will not be displayed



---

### 3.3.6.2 RULER(2): Analog bar display

Analog bar can be set up displayed or hidden.

- Hiding the analog bar
  1. Press the upper right key in the measurement mode to move the setup mode, and select OTHER functions. (Refer to "3.3.6 OTHER: Other functions".)
  2. Press the lower left or lower right key until "RULER" is blinking.
  3. Press the center key to move the ON/OFF selection of the analog bar display.
  4. Press the lower left key to select "OFF".
  5. Press the center key to hide the analog bar and return to the parameter setting. (Refer to "3.3 Setup Mode".)
- Displaying the analog bar
  1. Press the upper right key in the measurement mode to move the setup mode, and select OTHER functions. (Refer to "3.3.6 OTHER: Other functions".)
  2. Press the lower left or lower right key until "RULER" is blinking.
  3. Press the center key to move the ON/OFF selection of the analog bar display.
  4. Press the lower left key to select "ON".
  5. Press the center key to hide the analog bar and return to the parameter setting. (Refer to "3.3 Setup Mode".)

---

**NOTE** • The analog bar will not be displayed if the graduation is changed while it is hidden. (Refer to "3.3.4 SCALE: Selecting analog bar graduation".)

---

**Hiding the analog bar**

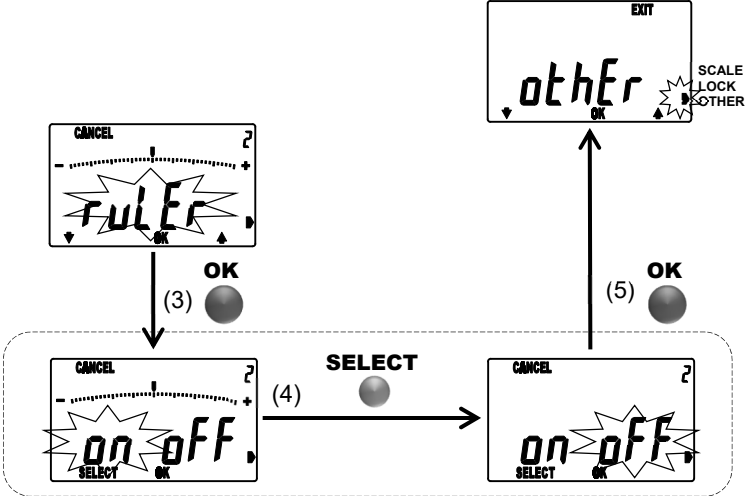

**Displaying the analog bar**

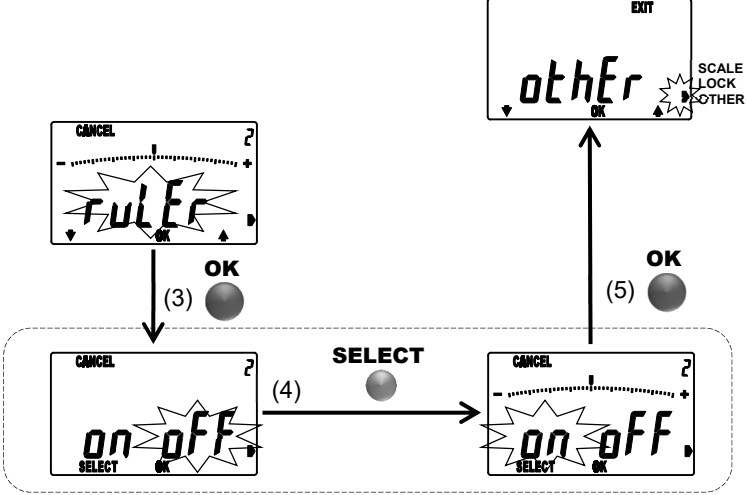

---

### 3.3.6.3 FAST(3): FAST mode

When enabling the FAST mode, it enables to detect peak value more correctly.  
Auto-off function is disabled in FAST mode.

- Enabling the FAST mode
  1. Press the upper right key in the measurement mode to move the setup mode, and select OTHER functions. (Refer to "3.3.6 OTHER: Other functions".)
  2. Press the lower left or lower right key until "FAST" is blinking.
  3. Press the center key to move the ON/OFF selection of the FAST mode.
  4. Press the lower left key to select "ON".
  5. Press the center key to enable this function and return to the parameter setting. (Refer to "3.3 Setup Mode".)
- Disabling the FAST mode
  1. Press the upper right key in the measurement mode to move the setup mode, and select OTHER functions. (Refer to "3.3.6 OTHER: Other functions".)
  2. Press the lower left or lower right key until "FAST" is blinking.
  3. Press the center key to move the ON/OFF selection of the FAST mode.
  4. Press the lower left key to select "ON".
  5. Press the center key to disable this function and return to the parameter setting. (Refer to "3.3 Setup Mode".)

---

**IMPORTANT** ▪ The accuracy will not be affected by this function.

---

**NOTE** ▪ Operating in this function will shorten the battery life.  
It is recommended to operate with disabling this function if not necessary.

---

**Enabling the FAST mode**

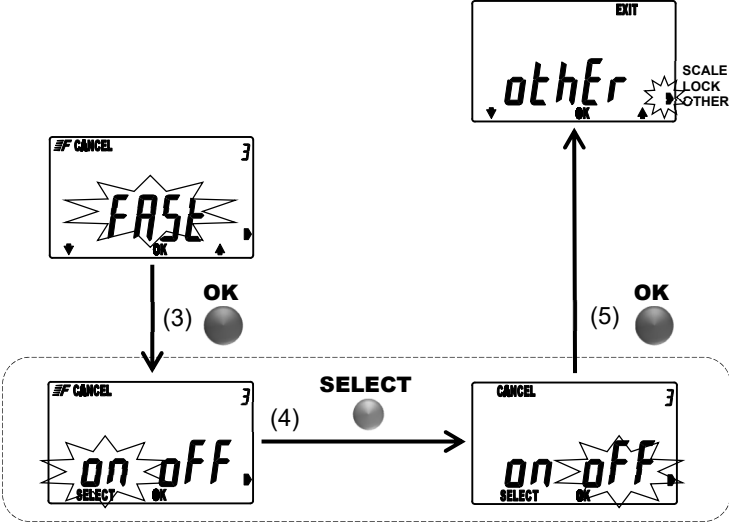

**Disabling the FAST mode**

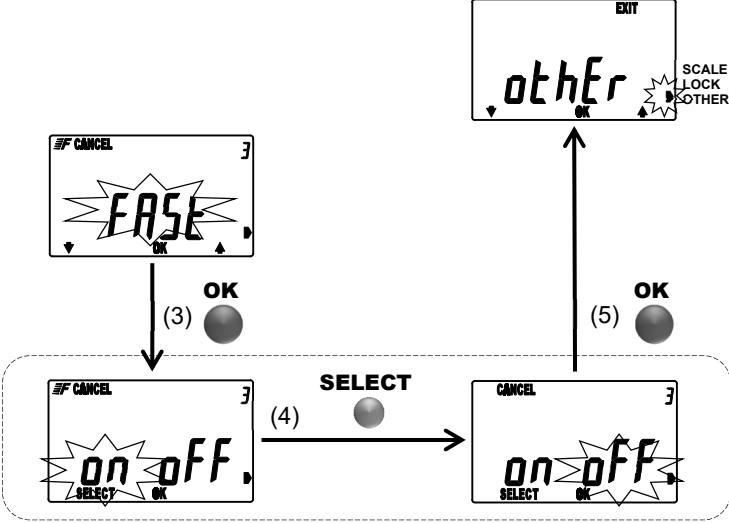

---

### 3.3.6.4 RESET(4): All reset

It restores the factory default.

- Executing all reset
  1. Press the upper right key in the measurement mode to move the setup mode, and select OTHER functions. (Refer to "3.3.6 OTHER: Other functions".)
  2. Press the lower left or lower right key until "RESET" is blinking.
  3. Press the center key to move the all reset setting.
  4. Press the lower left key to select "YES".
  5. Press the center key, then "YES" will be displayed again.
  6. Press the center key to execute all reset.

The display turns off shortly, and restores the display of the time when the battery is installed.

---

**IMPORTANT** · The setting before executing all reset cannot be restored.

---

#### Factory default

Setting items	Settings
Preset	Preset No. (P1/P2/P3): P1 Preset values (P1/P2/P3): Zero for all
Measuring system	ABS
Counting direction	Plus (When pushed the spindle)
Unit	mm (for inch models: in)
Peak detection mode	OFF
Center position of the analog bar	Centered at zero
Tolerance judgment	OFF Tolerance judgment (upper limit/lower limit): Zero for all
Resolution	0.001mm (0.00005in)
Calculation function	OFF Calculation coefficient: A=1.0000
Analog bar graduation	Auto
Key-lock	OFF All key function: Enabled
Analog bar display	ON
FAST mode	OFF
Parameter-lock	OFF

**Excuting all reset**

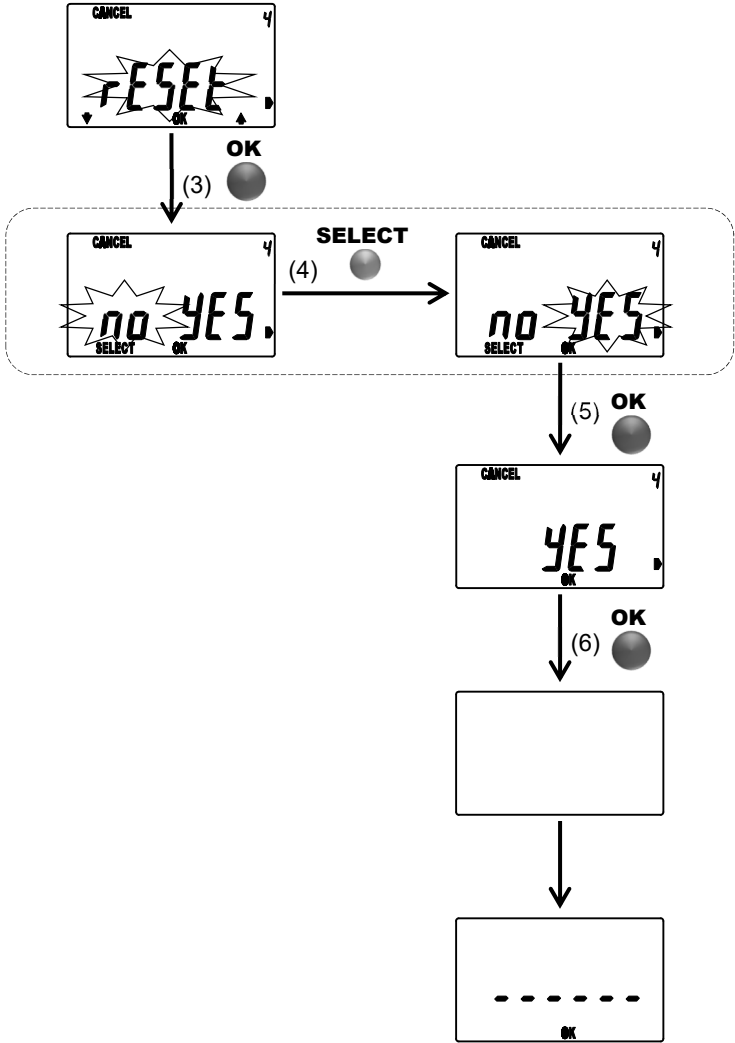

## 3.4 Calibration mode

In this mode the instrument can measure with an appropriate setting of accuracy inspection and calibration while retaining the current settings in memory. And also in this mode when the instrument receives an output request (REQ) from the data processor, it outputs a display value. (Refer to 3.2.7 Display value output)

The settings of calibration mode  
(The settings change automatically when starting the calibration mode)

Setting items	Settings
Measurement mode	Normal mode
Measuring system	INC
Unit	mm / in(for inch models)
Resolution	0.001mm / 0.00005in(for inch models)
Other	Tolerance judgment :OFF Calculation function :OFF Key-lock :OFF Analog bar display :OFF

Key function for the calibration mode

Keys	Press	Press and hold
Lower left	-	-
Center	Set to zero	-
Lower right	-	Switching the units
Upper left	-	
Upper right	-	

### ● Starting the calibration mode

1. Remove the battery holder by using a flat-blade screwdriver or the like.
2. While pressing the lower left key and center key, set to the battery holder. This instrument will be started up in the calibration mode.

### ● Stopping the calibration mode

1. Remove the battery holder, so it means stopping the calibration mode. The measurement mode (the normal mode) will be restarted when the battery holder is set into the original position again (Refer to 2. SETUP).

### IMPORTANT

- The preset setting is required in the measurement mode after using this mode (Refer to 3.2.1 Preset setting). However other settings and parameters are held with the former setting which moves to this mode.

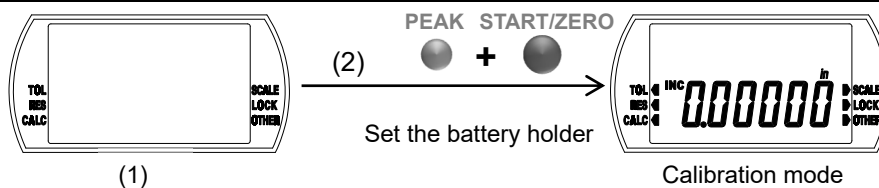

# 4

## DATA OUTPUT

This chapter describes how to output data.

---

The measurement data can be outputted to the data processor such as Digimatic Mini-processor DP-1VR with an optional connecting cable (Parts No. 905338 (1m) or No. 905409 (2m)). And the data can be summed up or recorded

---

### NOTE

- Use only the output cable of Mitutoyo specific accessories. The use of an improper cable or deteriorated cable may disable data output.
  - Prior to data output carefully read the user's manual of the data processor to use it correctly.
- 

### 4.1 Cable Connection

---

Remove the output connector cap, and then connect the instrument to the data processor by using a connecting cable. Insert the cable securely to the end, in the direction as shown.

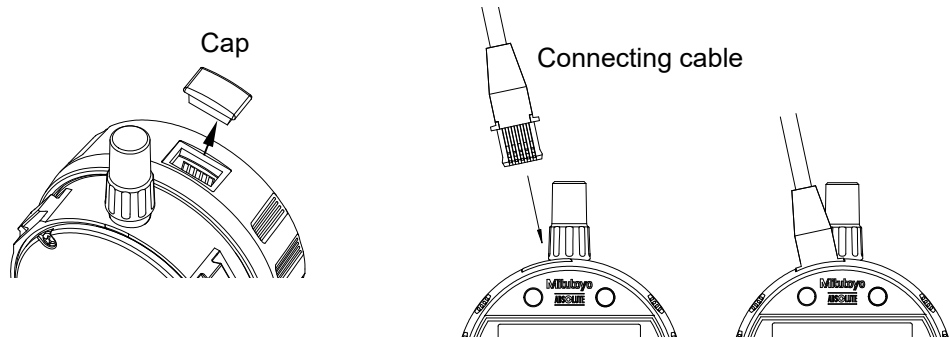

### NOTE

- Store the removed cap, taking care to prevent loss.
  - Install the direction of output pin correctly.
  - Be sure to attach a cap to the connecting cable when not in use.
-



## 4.2 Output Connector

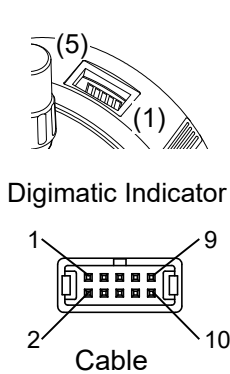

Indicator	Pin No.		Signal	I/O
	Indicator	Cable		
1	1	1	GND	-
2 *1	2	2	DATA	O
3 *1	3	3	$\overline{\text{CK}}$	O
4 *1	4	4	$\overline{\text{RD}}$	O
5 *2	5	5	$\overline{\text{REQ}}$	I
-	6-10	-	N.C.	-

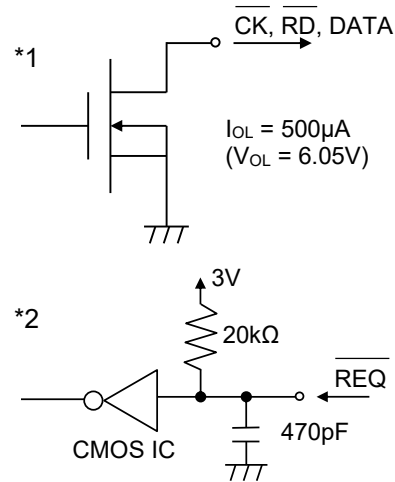

### IMPORTANT

- Since the power voltage differs between this instrument and the data processor, absolutely design an output system either open-collector or open-drain. Do not use CMOS output.

## 4.3 Output Data Format

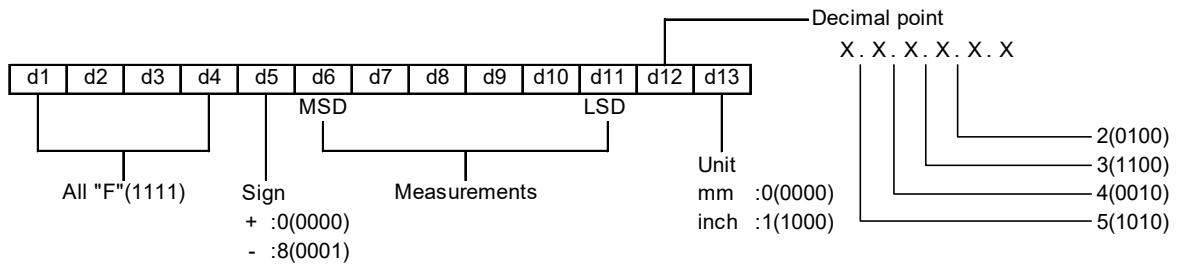

※This instrument outputs 13 digits from d1 to d13 by making 4 bits into 1 digit.

※Each digit is outputted in the order from least significant bit (LSB) to most significant bit (MSB).

---

## 4.4 Timing Chart

---

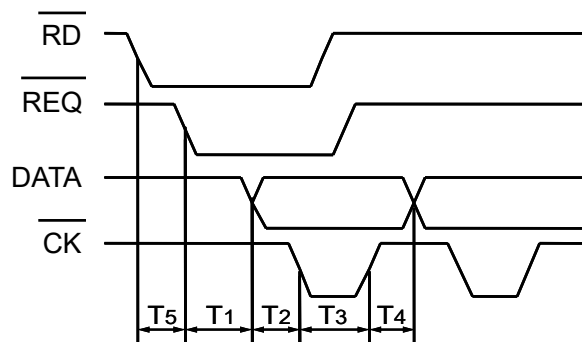

$0.7 \text{ ms} \leq T1 \leq 1.2 \text{ ms}$   
 $100 \text{ } \mu\text{s} \leq T2 \leq 200 \text{ } \mu\text{s}$   
 $200 \text{ } \mu\text{s} \leq T3 \leq 300 \text{ } \mu\text{s}$   
 $100 \text{ } \mu\text{s} \leq T4 \leq 200 \text{ } \mu\text{s}$   
T5 : Determined by the performance  
of the data processor

---

### IMPORTANT

- If the output request (REQ) signal is received during the spindle displacement or if the inverter receives output request (REQ) signals repeatedly at short intervals, the instrument may not output data.
- 

### NOTE

- Retain the REQ signal at Low level until the CK signal is outputted. Also, return the REQ signal to High level before the last CK signal (at the 52nd bit) is outputted.
-

---



MEMO



# 5

## ERROR MESSAGE AND ACTION

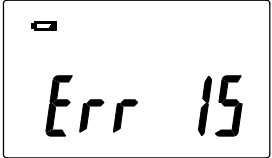
This chapter describes the error messages and their corrective actions.

If any error occurs in this Digimatic indicator, a corresponding error message is displayed. If the instrument does not recover the normal conditions after corrective actions, contact your dealer or Mitutoyo sales office.

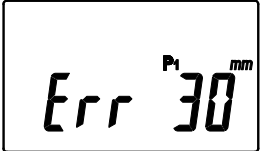
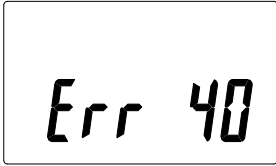
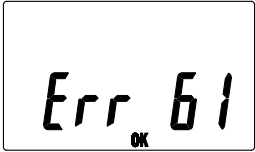
Display	definition	Actions
	Low battery alarm <ul style="list-style-type: none"> <li>Battery voltage is getting low</li> </ul>	<ul style="list-style-type: none"> <li>Replace the battery with the new one.</li> </ul>
	Low battery error <ul style="list-style-type: none"> <li>Measurement cannot be performed due to consumption of the battery.</li> </ul>	<ul style="list-style-type: none"> <li>Replace the battery with the new one.</li> </ul>
	Sensor signal synthesizing error <ul style="list-style-type: none"> <li>Synthesizing of sensor signal is failed.</li> </ul>	<ul style="list-style-type: none"> <li>A sensor signal synthesizing error occurred while the spindle was moving at high speed. Keep on using the indicator since this error does not affect measured values.</li> <li>* If this error occurs while the spindle is stopped, it could be due to sensor failure. In this case, contact the nearest Mitutoyo sales office.</li> </ul>

Display	definition	Actions
	<p>Overflow error of display value</p> <ul style="list-style-type: none"> <li>The display value has exceeded the maximum number of digits that can be displayed.</li> </ul>	<ul style="list-style-type: none"> <li>Return the display value to the permissible number of digits to automatically reset the error.</li> <li>Press the center key, or press and hold</li> <li>Move the Setup mode to change the resolution. (Refer to "3.3.2 RES: Resolution".)</li> <li>Move the Setup mode to reset the calculation coefficient.</li> </ul>
	<p>Internal connection error</p>	<ul style="list-style-type: none"> <li>This could be due to instrument failure. In this case, contact your dealer or Mitutoyo sales office.</li> </ul>
	<p>Setting value rewrite error</p> <ul style="list-style-type: none"> <li>A setting value has been rewritten from any cause after the previous use.</li> </ul>	<ul style="list-style-type: none"> <li>Press the center key will return to the initial state after setting the battery. Perform re-setting after confirming the setting value, referring to "2.1 Installation (replacement) of Battery and Initial Setting".</li> </ul>
	<p>Setting value storage error</p> <ul style="list-style-type: none"> <li>A setting value could not be stored.</li> <li>A setting value could not be loaded.</li> </ul>	<ul style="list-style-type: none"> <li>Remove the battery once and perform re-setting, referring to "2.1 Installation (replacement) of Battery and Initial Setting".</li> <li>If this error occurs even after re-setting the battery, replace it.</li> <li>If this error occurs even after replacing the battery, it could be due to instrument failure. In this case, contact your dealer or Mitutoyo sales office.</li> </ul>

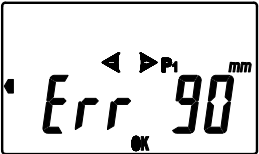
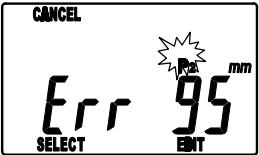
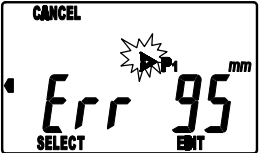
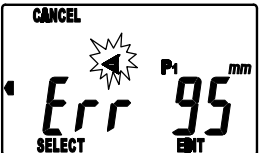
Display	definition	Actions
	Internal program error <ul style="list-style-type: none"> <li>Measurement cannot be performed due to occurrence of an anomaly in the internal program.</li> </ul>	<ul style="list-style-type: none"> <li>This could be due to instrument failure. In this case, contact your dealer or Mitutoyo sales office.</li> </ul>
	Tolerance upper/lower limit setting error <ul style="list-style-type: none"> <li>The tolerance limit value is set with the upper limit value being smaller than the lower limit value.</li> </ul>	<ul style="list-style-type: none"> <li>Press the center key to reset to be the upper limit value is greater than the lower limit value. (Refer to "3.3.1 TOL: Tolerance judgment".)</li> </ul>
	Overflow error of preset value <ul style="list-style-type: none"> <li>The preset value has exceeded the maximum number of digits that can be displayed.</li> </ul>	<ul style="list-style-type: none"> <li>Press the lower right key to reset the preset value.</li> <li>Lower the resolution. (Refer to "3.3.2 RES: Resolution".)</li> </ul>
	Overflow error of upper limit value <ul style="list-style-type: none"> <li>The upper limit value has exceeded the maximum number of digits that can be displayed.</li> </ul>	<ul style="list-style-type: none"> <li>Press the lower right key to reset the upper limit value. (Refer to "3.3.1 TOL: Tolerance judgment".)</li> <li>Lower the resolution. (Refer to "3.3.2 RES: Resolution".)</li> </ul>
	Overflow error of lower limit value <ul style="list-style-type: none"> <li>The lower limit value has exceeded the maximum number of digits that can be displayed.</li> </ul>	<ul style="list-style-type: none"> <li>Press the lower right key to reset the lower limit value. (Refer to "3.3.1 TOL: Tolerance judgment".)</li> <li>Lower the resolution. (Refer to "3.3.2 RES: Resolution".)</li> </ul>

---

MEMO

## Europe

### Mitutoyo Europe GmbH

Borsigstrasse 8-10, 41469 Neuss, GERMANY  
TEL: 49(0)2137 102-0 FAX: 49(0)2137 102-351

### Mitutoyo CTL Germany GmbH

Von-Gunzert-Strasse 17, 78727 Oberndorf, GERMANY  
TEL: 49(0)7423 8776-0 FAX: 49(0)7423 8776-99

### KOMEG Industrielle Messtechnik GmbH

Zum Wasserwerk 3, 66333 Völklingen, GERMANY  
TEL: 49(0)6898 91110 FAX: 49(0)6898 9111100

## Germany

### Mitutoyo Deutschland GmbH

Borsigstrasse 8-10, 41469 Neuss, GERMANY  
TEL: 49(0)2137 102-0 FAX: 49(0)2137 86 85

### M<sup>3</sup> Solution Center Hamburg

Tempowerkring 9 im HIT-Technologiepark 21079 Hamburg, GERMANY

TEL: 49(0)40 791894-0 FAX: 49(0)40 791894-50

### M<sup>3</sup> Solution Center Berlin

Ernst-Lau-Straße 6, 12489 Berlin, GERMANY  
TEL: 49(0)30 2611 267 FAX: 49 30 67988729

### M<sup>3</sup> Solution Center Eisenach

Neue Wiese 4, 99817 Eisenach, GERMANY  
TEL: 49(0)3691 88909-0 FAX: 49(0)3691 88909-9

### M<sup>3</sup> Solution Center Ingolstadt

Marie-Curie-Strasse 1A, 85055 Ingolstadt, GERMANY  
TEL: 49(0)841 954920 FAX: 49(0)841 9549250

### M<sup>3</sup> Solution Center Leonberg

Am Längenbühl 3, 71229 Leonberg, GERMANY  
TEL: 49(0)7152 6080-0 FAX: 49(0)7152 608060

### Mitutoyo Deutschland GmbH - Small Tool Sales Division

Heidenheimer Strasse 14, 71229 Leonberg, GERMANY  
TEL: 49(0)7152 9237-0 FAX: 49(0)7152 9237-29

## U.K.

### Mitutoyo (UK) Ltd. HQ

Joule Road, West Point Business Park, Andover, Hampshire SP10 3UX, UNITED KINGDOM

TEL: 44(0)1264 353123 FAX: 44(0)1264 354883

### Coventry M<sup>3</sup> Solution Centre

Unit6, Banner Park, Wickmans Drive, Coventry, West Midlands CV4 9XA, UNITED KINGDOM

TEL: 44(0)2476 426300

### Halifax M<sup>3</sup> Solution Centre

Lowfields Business Park, Navigation Close, Elland, West Yorkshire HX5 9HB, UNITED KINGDOM

TEL: 44(0)1422 375566

### East Kilbride M<sup>3</sup> Solution Centre

The Bairds Building, Rankine Avenue, Scottish Enterprise Technology Park, East Kilbride G75 0QF, UNITED KINGDOM

TEL: 44(0)1355 581170

## France

### Mitutoyo France

Paris Nord 2-123 rue de la Belle Etoile, BP 59267 ROISSY EN FRANCE 95957 ROISSY CDG CEDEX, FRANCE

TEL: 33(0)149 38 35 00

### M<sup>3</sup> Solution Center LYON

Parc Mail 523, cours du 3ème millénaire, 69791 Saint-Priest, FRANCE

TEL: 33(0)149 38 35 70

### M<sup>3</sup> Solution Center STRASBOURG

Parc de la porte Sud, Rue du pont du péage, 67118 Geispolsheim, FRANCE

TEL: 33(0)149 38 35 80

### M<sup>3</sup> Solution Center CLUSES

290 Avenue des Lacs, 74950 Scionzier, FRANCE  
TEL: 33(0)1 49 38 35 90

### M<sup>3</sup> Solution Center TOULOUSE

Aeroparc Saint Martin Cellule B08  
ZAC de Saint Martin du Touch 12 rue de Caulet  
31300 Toulouse, FRANCE

TEL: 33(0)1 49 38 42 90

### M<sup>3</sup> Solution Center RENNES

2, rue Claude Chappe, PA le Vallon - ZAC Mivoie, 35230 Noyal-Châtillon-sur-Seiche, FRANCE

TEL: 33(0)1 49 38 42 10

## Italy

### Mitutoyo Italiana S.r.l.

Corso Europa, 7 - 20045 Lainate (MI), ITALY  
TEL: 39 02 935781 FAX: 39 02 93578255

### M<sup>3</sup> Solution Center BOLOGNA

Via dei Carpini1/A - 40011 Anzola Emilia (BO), ITALY  
TEL: 39 02 93578215 FAX: 39 02 93578255

### M<sup>3</sup> Solution Center CHIETI

Contrada Santa Calcagna - 66020 Rocca S. Giovanni (CH), ITALY

TEL: 39 02 93578280 FAX: 39 02 93578255

### M<sup>3</sup> Solution Center PADOVA

Via G. Galilei 21/F - 35035 Mestrino (PD), ITALY  
TEL: 39 02 93578268 FAX: 39 02 93578255

## Netherlands

### Mitutoyo Nederland B.V.

Storkstraat 30, 3905 KX Veenendaal, THE NETHERLANDS  
TEL: 31(0)318-534911

### Mitutoyo Nederland B.V. / M<sup>3</sup> Solution Center Enschede

Institutenweg 50, 7521 PK Enschede, THE NETHERLANDS  
TEL: 31(0)318-534911

### Mitutoyo Nederland B.V. / M<sup>3</sup> Solution Center Eindhoven

De Run 1115, 5503 LB Veldhoven, THE NETHERLANDS  
TEL: 31(0)318-534911

### Mitutoyo Research Center Europe B.V.

De Rijn 18, 5684 PJ Best, THE NETHERLANDS  
TEL:31(0)499-320200 FAX:31(0)499-320299

## Belgium

### Mitutoyo Belgium N.V. / M<sup>3</sup> Solution Center Melsele

Schaarbeekstraat 20, B-9120 Melsele, BELGIUM  
TEL: 32(0)3-2540444

## Sweden

### Mitutoyo Scandinavia AB

Släntvägen 6, 194 61 Upplands Väsby, SWEDEN  
TEL: 46(0)8 594 109 50

### Mitutoyo Scandinavia AB / M<sup>3</sup> Solution Center Alingsås

Ångsvaktaregatan 3A, 441 38 Alingsås, SWEDEN  
TEL: 46(0)8 594 109 50

### Mitutoyo Scandinavia AB / M<sup>3</sup> Solution Center Värnamo

Kalkstensvägen 7, 331 44 Värnamo, SWEDEN  
TEL: 46(0)8 594 109 50

## Switzerland

### Mitutoyo (Schweiz) AG

Steinackerstrasse 35, 8902 Urdorf, SWITZERLAND  
TEL: 41(0)447361150

### Mitutoyo (Suisse) SA

Rue Galilée 4, 1400 Yverdon-les Bains, SWITZERLAND  
TEL: 41(0)244259422



# SERVICE NETWORK

\*As of June 2023

## Poland

### Mitutoyo Polska Sp.z o.o.

Ul.Graniczna 8A, 54-610 Wrocław, POLAND  
TEL: 48(0)71354 83 50 FAX: 48(0)71354 83 55

## Czech Republic

### Mitutoyo Česko s.r.o.

Dubská 1626, 415 01 Teplice, CZECH REPUBLIC  
TEL: 420 417-514-011 Email: info@mitutoyo.cz

### Mitutoyo Česko s.r.o. M<sup>®</sup> Solution Center Ivančice

Ke Karlovu 62/10, 664 91 Ivančice, CZECH REPUBLIC  
TEL: 420 417-514-011 Email: info@mitutoyo.cz

### Mitutoyo Česko s.r.o. M<sup>®</sup> Solution Center Ostrava Mošnov

Mošnov 314, 742 51 Mošnov, CZECH REPUBLIC  
TEL: 420 417-514-050 Email: info@mitutoyo.cz

### Mitutoyo Česko s.r.o. Slovakia Branch

Hviezdoslavova 124, 017 01 Povážská Bystrica, SLOVAKIA  
TEL: 421 948-595-590 Email: info@mitutoyo.sk

## Hungary

### Mitutoyo Hungária Kft.

Galamb József utca 9, 2000 Szentendre, HUNGARY  
TEL: 36 (30) 6410210

## Romania

### Mitutoyo Romania SRL

1A Drumul Garii Odai Street, showroom, Ground Floor,  
075100 OTOPENI-ILFOV, ROMANIA  
TEL: 40(0)311012088 FAX: 40(0)311012089

### Showroom in Brasov

Strada Ionescu Crum Nr.1, Brasov Business Park Turnul 1,  
Mezanin, 500446 Brasov-Judetul Brasov, ROMANIA  
TEL/FAX: 40(0)371020017

## Finland

### Mitutoyo Scandinavia AB Finnish Branch

Viherkiitäjä 2A, 33960, Pirkkala, FINLAND  
TEL: 358(0)40 355 8498

## Austria

### Mitutoyo Austria GmbH

Salzburger Straße 260 / 3A-4600 Wels, AUSTRIA  
TEL: 43(0) 7242 219 998

### Mitutoyo Austria GmbH Goetzis Regional showroom

Lastenstrasse 48a, 6840 Götzis, AUSTRIA

## Singapore

### Mitutoyo Asia Pacific Pte. Ltd.

### Head office / M<sup>®</sup> Solution Center

24 Kallang Avenue, Mitutoyo Building, SINGAPORE 339415  
TEL: (65)62942211 FAX: (65)62996666

## Malaysia

### Mitutoyo (Malaysia) Sdn. Bhd.

### Kuala Lumpur Head Office / M<sup>®</sup> Solution Center

Mah Sing Integrated Industrial Park, 4, Jalan Utarid U5/14,  
Section U5, 40150 Shah Alam, Selangor, MALAYSIA  
TEL: (60)3-78459318 FAX: (60)3-78459346

### Penang Branch office / M<sup>®</sup> Solution Center

30, Persiaran Mahsuri 1/2, Sunway Tunas, 11900 Bayan  
Lepas, Penang, MALAYSIA  
TEL: (60)4-6411998 FAX: (60)4-6412998

### Johor Branch office / M<sup>®</sup> Solution Center

70 (Ground Floor), Jalan Molek 1/28, Taman Molek, 81100  
Johor Bahru, Johor, MALAYSIA  
TEL: (60)7-3521626 FAX: (60)7-3521628

## Thailand

### Mitutoyo (Thailand) Co., Ltd.

### Bangkok Head Office / M<sup>®</sup> Solution Center

76/3-5, Chaengwattana Road, Kwaeng Anusaawaree, Khet  
Bangkaen, Bangkok 10220, THAILAND  
TEL: (66)2080 3500 FAX:(66)2521 6136

### Chonburi Branch / M<sup>®</sup> Solution Center

7/1, Moo 3, Tambon Bowin, Amphur Sriracha, Chonburi  
20230, THAILAND

TEL: (66)2080 3563 FAX:(66)3834 5788

### ACC Branch / M<sup>®</sup> Solution Center

122/8, 122/9, Moo 6, Tambon Donhuaroh,  
Amphur Muangchonburi, Chonburi 20000, THAILAND  
TEL: (66)2080 3565

## Indonesia

### PT. Mitutoyo Indonesia

### Head Office / M<sup>®</sup> Solution Center

Jalan Sriwijaya No.26 Desa cibatu Kec. Cikarang Selatan  
Kab. Bekasi 17530, INDONESIA

TEL: (62)21-2962 8600 FAX: (62)21-2962 8604

### Batam Branch Office

Business Center Adhya Building 3rd Floor Kompleks  
Permata Niaga Blok A No. 1, Jalan jendral Sudirman  
Kelurahan Sukajadi, Kecamatan Batam Kota, Kepulauan  
Riau 29444, INDONESIA  
TEL: (62)-778-4888000

## Vietnam

### Mitutoyo Vietnam Co., Ltd

### Hanoi Head Office / M<sup>®</sup> Solution Center

1st & 2nd floor, MHDl Building, No. 60 Hoang Quoc Viet  
Road, Nghia Do Ward, Cau Giay District, Hanoi, VIETNAM  
TEL: (84)24-3768-8963 FAX: (84)24-3768-8960

### Ho Chi Minh City Branch Office / M<sup>®</sup> Solution Center

Unit No. B-00.07, Ground Floor, C1 Building, No. 6, Street  
D9, An Loi Dong Ward, Thu Duc City, Ho Chi Minh City,  
VIETNAM

TEL: (84)28-3840-3489 FAX: (84)28-3840-3498

### Hai Phong City Branch Office

Room 511, 5th Floor, Thanh Dat 3 Building, No. 4 Le Thanh  
Tong Street, May To Ward, Ngo Quyen District, Hai Phong  
City, VIETNAM

TEL:(84)22-5398-9909

## Philippines

### Mitutoyo Philippines, Inc.

### Head Office / M<sup>®</sup> Solution Center

Unit 1B & 2B LTI, Administration Building 1, Annex 1,  
North Main Avenue, Laguna Technopark, Binan Laguna  
4024, PHILIPPINES

TEL/FAX:(63) 49 544 0272

## India

### Mitutoyo South Asia Pvt. Ltd. Head Office

C-122, Okhla Industrial Area, Phase-1, New Delhi-110 020,  
INDIA

TEL: (91) 11-40578485/86

### MSA Technical Center

Plot no. 65, Ground Floor, Udyog Vihar, Phase-4 Gurgaon,  
Haryana - 122016, INDIA  
TEL: (91) 124-2340286/287

### Mumbai Region Head office

303, Sentinel Hiranandani Business Park Powai,  
Mumbai-400 076, INDIA

TEL: (91) 22-25700684/685/837/839

# SERVICE NETWORK

\*As of June 2023

## **Pune Office / M<sup>o</sup> Solution Center**

G4/G5, Pride Kumar Senate, Off. Senapati Bapat Road,  
Pune-411 016, INDIA  
TEL: (91) 20-25660043/44/45

## **Ahmedabad Office / M<sup>o</sup> Solution Center**

A-104 & A-105, First Floor, Solitaire Corporate Park, Near  
Divya Bhaskar Press, S.G. Road, Ahmedabad - 380 015,  
INDIA  
TEL: (91)079 - 29704902/903

## **Bengaluru Region Head office / M<sup>o</sup> Solution Center**

116/117-2, Ground Floor, Sy. No. 93 & 94, 3rd Phase, Peenya  
Industrial Area, Bengaluru-560 058, INDIA  
TEL: (91) 80-25630946/47/48/49

## **Coimbatore Office**

Regus, Srivari Srimath, 3rd Floor, Door No: 1045, Avinashi  
Road, Coimbatore - 641 018,INDIA  
TEL: (91)9345005663

## **Chennai Office / M<sup>o</sup> Solution Center**

No. 624, Anna Salai Teynampet, Chennai-600 018, INDIA  
TEL: (91) 44-24328823/24/25

## **Kolkata Office**

Unit No. 1208,Om Tower, 32,J.L.Nehru Road, Kolkata-700  
071, INDIA  
TEL: (91) 33-22267088/40060635/22266817

## **Taiwan**

### **Mitutoyo Taiwan Co., Ltd. / M<sup>o</sup> Solution Center Taipei**

4F., No.71, Zhouzi St., Neihu Dist.,Taipei City 114, TAIWAN  
TEL: 886(2)5573-5900 FAX: 886(2)8752-3267

### **Taichung Branch / M<sup>o</sup> Solution Center Taichung**

1F., No. 299, Gaotie 1st Rd., Wuri Dist., Taichung City 414,  
TAIWAN  
TEL:886(4)2338-6822 FAX:886(4)2338-6722

### **Kaohsiung Branch / M<sup>o</sup> Solution Center Kaohsiung**

1F., No.31-1, Haibian Rd., Lingya Dist., Kaohsiung City 802,  
TAIWAN  
TEL: 886(7)334-6168 FAX: 886(7)334-6160

## **South Korea**

### **Mitutoyo Korea Corporation**

#### **Head Office / M<sup>o</sup> Solution Center**

(Sanbon-Dong, Geumjeong High View Build.), 6F, 153-8,  
Ls-Ro, Gunpo-Si, Gyeonggi-Do, 15808 KOREA  
TEL: 82(31)361-4200 FAX: 82(31)361-4201

#### **Busan Office / M<sup>o</sup> Solution Center**

(3150-3, Daejeo 2-dong) 8,Yutongdanji 1-ro 49beon-gil,  
Gangseo-gu, Busan, 46721 KOREA  
TEL: 82(51)718-2140 FAX: 82(51)324-0104

#### **Daegu Office / M<sup>o</sup> Solution Center**

(Galsan-dong, Daegu Business Center), 301-Ho, 217,  
Seongseogongdan-ro, Dalseo-gu, Daegu 42704 KOREA  
TEL: 82(53)593-5602 FAX: 82(53)593-5603

## **China**

### **Mitutoyo Measuring Instruments (Shanghai) Co., Ltd.**

8th Floor, Tower 1 Lujiazui Jinkong Square No.1788/1800  
Century Ave., Pudong New District, Shanghai 200122,  
CHINA  
TEL: 86(21)5836-0718 FAX: 86(21)5836-0717

### **Suzhou Office / M<sup>o</sup> Solution Center China (Suzhou)**

1/2 Floor, Building 4, No.175 Songbei Road, Suzhou Free  
Trade Zone, Suzhou City, Jiangsu 215000, CHINA  
TEL: 86(512)6522-1790 FAX: 86(512)6251-3420

### **Wuhan Office / M<sup>o</sup> Solution Corner**

Room 1701, Wuhan Wanda Center, No. 96, Linjiang Road,  
Wuchang District, Wuhan Hubei 430060, CHINA  
TEL: 86(27)8544-8631 FAX: 86(27)8544-6227

## **Chengdu Office**

Room 1-102, 1st Floor, Unit 1, Building 1, No. 24, Wannian  
Road (Wanniancang Cool), Chenghua District, Chengdu City,  
Sichuan 610056, CHINA  
TEL: 86(28)8671-8936 FAX: 86(28)8671-9086

## **Hangzhou Office**

Room 804, Eastern International Business Center Building 1,  
No.600 Jinsha Road of Hangzhou Economic and  
Technological Development Zone, 310018, CHINA  
TEL: 86(571)8288-0319 FAX: 86(571)8288-0320

## **Tianjin Office / M<sup>o</sup> Solution Center China (Tianjin)**

Room D 12/F, TEDA Building, No.256 Jie-fang Nan Road  
Hexi District, Tianjin 300042, CHINA  
TEL: 86(22)5888-1700 FAX: 86(22)5888-1701

## **Changchun Office**

Room 815, 8F, Building A1, Upper East International  
No.3000 Dongsheng Street, Erdao District, Changchun, Jilin,  
130031, CHINA  
TEL: 86(431)8192-6998 FAX: 86(431)8192-6998

## **Chongqing Office**

Room 1312, Building 3, Zhongyu Plaza, No.86, Hongjin  
Avenue, Longxi Street, Yubei District, Chongqing, 400000,  
CHINA  
TEL: 86(23)6595-9950 FAX: 86(23)6595-9950

## **Qingdao Office**

Room 638, 6F, No.192 Zhengyang Road, Chengyang District,  
Qingdao, Shandong, 266109, CHINA  
TEL: 86(532)8096-1936 FAX: 86(532)8096-1937

## **Xi'an Office**

Room 805, Xi'an International Trade Center, No. 196  
Xiaozhai East Road, Xi'an, 710061, CHINA  
TEL: 86(29)8538-1380 FAX: 86(29)8538-1381

## **Dalian Office / M<sup>o</sup> Solution Center China (Dalian)**

Room A-106 Shuijing SOHO, No.16 Harbin Road, Economic  
Development Zone, Dalian, 116600 CHINA  
TEL: 86(411)8718 1212 FAX: 86(411)8754-7587

## **Zhengzhou Office**

Room1801,18/F,Unit1,Building No.23, Shangwu Inner Ring  
Road, Zhengdong New District,Zhengzhou City, Henan  
450018, CHINA  
TEL: 86(371)6097-6436 FAX: 86(371)6097-6981

## **Dongguan Office / M<sup>o</sup> Solution Center China (Dongguan)**

Room 801, No 65, Chang'an Section Guanchang Road,  
Chang'an Town, Dongguan City, Guangdong 523841, CHINA  
TEL: 86(769)8541 7715 FAX: 86(769)-8541 7745

## **Fuzhou Office**

Unit 03, 7th floor of East Tower, Sansheng International  
Center, No.118 Wusi Road, Gulou Distrit, Fuzhou City,  
Fujian 350001, CHINA  
TEL: 86 (591) 8761 8095 FAX: 86 (591) 8761 8096

## **Changsha Office**

Room 2207, Building 1, Shiner International Plaza, No. 88,  
Kaiyuan Middle Road, Changsha City, Hunan 410100,  
CHINA  
TEL: 86 (731) 8401 9276 FAX: 86 (731) 8401 9376

## **Changzhou Office**

Room 1502, Joint Financial Tower, No.255, Tongjiang North  
Road, Tianning District, Changzhou City, Jiangsu 2130002,  
CHINA  
TEL:86(519)8815 8319 FAX:86(519)8815 8319

## **Wenzhou Office**

Room 512, Building 4, Xijingdujiayuan, Sanyang Street,  
Ouhai District, Wenzhou City, Zhejiang 325014, CHINA  
TEL: 86(577)8641 5280

# SERVICE NETWORK

\*As of June 2023

## **Shunde Office**

Room 1603, Buliding 26, Vanke Golden Riverside Plaza Phase II, No.13 Mid DeSheng Road, ShunDe District, Foshan City, Guangdong 528300, CHINA  
TEL/FAX: 86(757)2228 8621

## **Mitutoyo Measuring Technology (Suzhou) Co., Ltd.**

1/2 Floor, Building 4, No.175 Songbei Road, Suzhou Free Trade Zone, Suzhou City, Jiangsu 215000, CHINA  
TEL: 86(512)6252-2660 FAX: 86(512)6252-2580

## **U.S.A.**

### **Mitutoyo America Corporation**

965 Corporate Blvd., Aurora, IL 60502, U.S.A.  
TEL: 1-(630)820-9666 Toll Free No. 1-888-648-8869  
FAX: 1-(630)978-3501

### **Headquarters (Aurora) / M<sup>o</sup> Solution Center**

965 Corporate Blvd., Aurora, IL 60502, U.S.A.

### **Seattle (Renton) Office / M<sup>o</sup> Solution Center**

1000 SW 34th St. Suite G, Renton, WA 98057 U.S.A.  
TEL: 1-(888)-648-8869

### **Houston Office / M<sup>o</sup> Solution Center**

4560 Kendrick Plaza Drive Suite 120 Houston, TX 77032, U.S.A.

TEL: 1-(888)-648-8869 FAX: 1-(281)227-0937

### **Cincinnati (Mason) Office / M<sup>o</sup> Solution Center**

6220 Hi-Tek Ct., Mason, OH 45040, U.S.A.  
TEL: 1-(888)-648-8869 FAX: 1-(513)754-0718

### **Detroit (Novi) Office / M<sup>o</sup> Solution Center**

46850 Magellan Drive, Suite 100, Novi, MI 48377, U.S.A.  
TEL: 1-(888)-648-8869 FAX: 1-(248)-926-0928

### **Los Angeles (City of Industry) Office / M<sup>o</sup> Solution Center**

16925 E. Gale Ave., City of Industry, CA 91745, U.S.A.  
TEL: 1-(888)-648-8869 FAX: 1-(626)369-3352

### **Charlotte (Huntersville) Office / M<sup>o</sup> Solution Center**

11515 Vanstory Dr., Suite 140, Huntersville, NC 28078, U.S.A.  
TEL: 1-(888)-648-8869 FAX: 1-(704)875-9273

### **Boston (Marlborough) Office / M<sup>o</sup> Solution Center**

753 Forest Street, Suite 110, Marlborough, MA 01752, U.S.A.  
TEL: 1-(888)648-8869 FAX: 1-(508)485-0782

### **Mitutoyo America Corporation Calibration Lab**

965 Corporate Blvd., Aurora, IL 60502, U.S.A.  
TEL: 1-(888)-648-8869 FAX: 1-(630)978-6477

### **Mitutoyo America Corporation CT-Lab Chicago**

965 Corporate Blvd., Aurora, IL 60502, U.S.A.  
TEL: 1-(888)-648-8869 FAX: 1-(630)-820-3418

### **Mitutoyo Research & Development America, Inc.**

11533 NE 118th St., Kirkland, WA 98034-7111, U.S.A.  
TEL: 1-(425)821-3906 FAX: 1-(425)821-3228

### **Mitutoyo Research & Development America, Inc. - California Office**

16925 Gale Ave. City of Industry, CA 91745-1806 U.S.A.  
TEL: 1-(425)821-3906 FAX: 1-(425)821-3228

## **Canada**

### **Mitutoyo Canada Inc.**

2121 Meadowvale Blvd., Mississauga, Ont. L5N 5N1., CANADA

TEL: 1-(905)821-1261 FAX: 1-(905)821-4968

### **Montreal Office**

7075 Place Robert-Joncas Suite 129, Montreal, Quebec H4M 2Z2, CANADA

TEL: 1-(514)337-5994 FAX: 1-(514)337-4498

## **Brazil**

### **Mitutoyo Sul Americana Ltda.**

#### **Head office / M<sup>o</sup> Solution Center**

Avenida Mimes n° 25 – Loteamento Multivias II, Jardim Ermida I, CEP 13212-216 Jundiáí - SP, BRASIL

TEL: 55 (11) 5643-0004/0041

## **Filial Curitiba / M<sup>o</sup> Solution Center**

Rua Sergipe, n° 101, Sala A, Bairro Boneca do Iguauçu, São José dos Pinhais – Paraná – BRASIL CEP 83040120  
TEL: 55 (41) 3534-1728

## **Argentina**

### **Mitutoyo Sul Americana Ltda.**

#### **Argentina Branch / M<sup>o</sup> Solution Center**

Av. B. Mitre 891/899 – C.P. (B1603CQD) Vicente López –Pcia. Buenos Aires – ARGENTINA

TEL: 54 (11) 4730-1433 FAX: 54 (11) 4730-1411

#### **Sucursal Cordoba / M<sup>o</sup> Solution Center**

Av. Ricchieri 2872 L.4 – B° Jardín – CP X5014OPJ Cordoba, ARGENTINA

TEL: 54 (351) 464-4125

## **Mexico**

### **Mitutoyo Mexicana, S.A. de C.V.**

Industria Eléctrica No.15, Parque Industrial, Naucalpan de Juárez, Estado de México C.P.53370, MÉXICO  
TEL: 52 (01-55) 5312-5612 FAX: 52 (01-55) 5312-3380

### **Monterrey Office / M<sup>o</sup> Solution Center**

Blv. Interamericana No. 103, Parque Industrial FINSA, C.P. 66636 Apodaca, N.L., MÉXICO

TEL: 52(01-81) 8398-8227/8228/8242/8244

FAX: 52(01-81) 8398-8226

### **Tijuana Office / M<sup>o</sup> Solution Center**

Calle José María Velazco 10501-C, Col. Cd. Industrial Nueva Tijuana, C.P. 22500 Tijuana, B.C., MÉXICO

TEL: 52(01-664) 647-5024

### **Querétaro Office / M<sup>o</sup> Solution Center**

Av. Cerro Blanco No.500-1, Colonia Centro Sur, Querétaro, Querétaro, C.P. 76090, MÉXICO

TEL: 52(01-442)340-8018, 340-8019 and 340-8020

FAX: 52(01-442)340-8017

### **Mitutoyo Mexicana, S.A. de C.V. Querétaro Calibration**

#### **Laboratory**

Av. Cerro Blanco 500 30 Centro Sur, Querétaro, Querétaro, C.P. 76090, MÉXICO

TEL: 52(01-442)340-8018, 340-8019 and 340-8020

FAX: 52(01-442)340-8017

### **Aguascalientes Office / M<sup>o</sup> Solution Center**

Av. Aguascalientes No. 622, Local 15 Centro Comercial El Cilindro Fracc. Pulgas Pandas Norte, C.P. 20138, Aguascalientes, Ags. MÉXICO

TEL: 52(01-449)174-4140 and 174-4143

### **Irapuato Office / M<sup>o</sup> Solution Center**

Boulevard a Villas de Irapuato No. 1460 L.1 Col. Ejido Irapuato C.P. 36643

Irapuato, Gto., MÉXICO

TEL: 52(01-462)144-1200 and 144-1400

## Mitutoyo Corporation

20-1, Sakado 1-Chome, Takatsu-ku, Kawasaki-shi, Kanagawa 213-8533, Japan

Tel: +81 (0)44 813-8230 Fax: +81 (0)44 813-8231

Home page: <http://www.mitutoyo.co.jp/global.html>