

# Linear Gage LGS SERIES

No.99MBC091B2  
Series No. 575



## Introduction

To obtain the highest performance and the longest service life from your Linear Gage, carefully read this User's Manual thoroughly prior to setup and operation. After reading this manual keep it near the Linear Gage for quick reference. The specifications of this gage and the description in this manual are subject to change without prior notification.

## Safety Precautions

To ensure operator safety, use the instrument in conformance with the directions and specifications given in this manual.

## Precautions for Use

Carefully avoid the following attempts to protect the instrument from failure and malfunction.

## IMPORTANT

- Do not apply sudden shocks including a drop or excessive force to the Linear Gage
- Do not disassemble or modify the gage.
- Do not use and store the gage at sites where it is exposed to direct sunlight or at extremely hot or cold sites.
- To use the gage highly accurately, avoid sites where the temperature will change abruptly.
- Absolutely do not apply an electric engraver to the gage. The high voltage may damage electronic parts. Also, do not use the gage at sites where it is subject to large electronic noises.
- Do not exert load on the spindle in the perpendicular direction and do not twist the spindle.
- Do not clamp the stem too tightly, since the spindle will not move smoothly.
- Do not apply excessive tension to the cable or do not bend it forcibly.
- To start measurement, wait 2 to 3 seconds after energizing.
- If the gage is used in combination with other instruments, the maximum performance could not be obtained depending on environment and operating conditions. Take those conditions into consideration prior to use.
- The functions and performance will not be guaranteed, if the gage is used in other conditions than those specified.
- Take sufficient damage-preventive processing (safety measures), should the gage have been at fault.



Please be careful enough when handling the knife edge or blade type contact point, since there is a possibility of injury at exchange and use.

## Electromagnetic Compatibility(EMC)

This product complies with the EMC Directive and the UK Electromagnetic Compatibility Regulations; however, if this receives electromagnetic interference that exceeds these requirements, it will be out of warranty and require appropriate measures.

## 1. Name and Dimension of Each Part

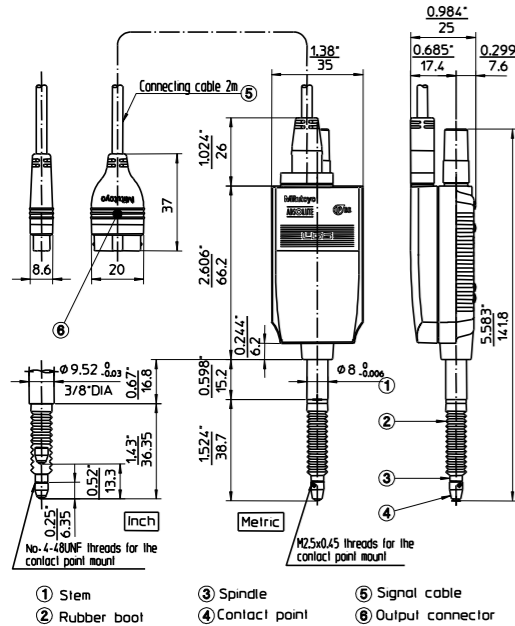

## 2. ABS Origin point

With this absolute sensor, the origin point cannot be reset even if the power is turned off. When the power is turned on, the sensor always outputs its positional data relative to the origin point. For the detailed method, refer to the User's Manual for the using counter.

## Tip

The ABS origin point has been set near the lowest end of the stroke before shipment.

## 3. Mounting the Gage

- To mount the gage on another instrument or a fixture, clamp the  $\phi 8$  stem
- It is recommended to use a slotted holder or a split bushing for the mount structure. (Recommended tightening torque in Example 1: 0.4 to 0.5 N·m)

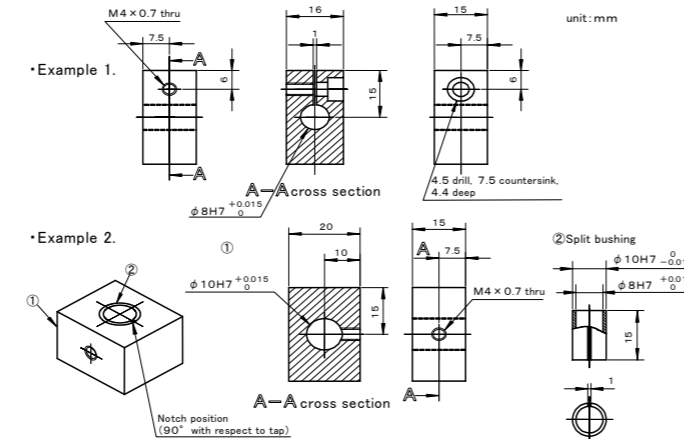

## IMPORTANT

- Avoid pressing the stem directly with set screws. If the screws are fastened tightly, the spindle will not slide properly.
- Mount the gage so that the spindle is directed perpendicular to the measured surface. If the gage is mounted at an oblique angle to the measured surface, an error may be generated in measurement results.

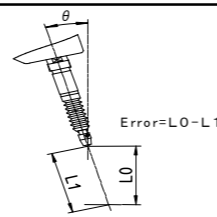

## 4. Precautions in Protecting the Gage from Dust and Water

### IMPORTANT

- The output connector plug (counter side) is not protective structured. Install the gage at a place where it is not splashed directly with water or oil.
- If the cable covering is broken, liquid will penetrate into the gage inside due to capillary phenomenon. This will cause damage to the gage.
- Be greatly careful not to damage the rubber boot due to chips, etc. If the rubber boot is damaged, dust-proof and water-proof function will be deteriorated. Immediately replace or repair the rubber boot.
- The materials including rubber which are used for the rubber boot and other sealing parts are not universal against diversified coolants and chemicals. If those parts deteriorate unusually, consult the nearest Mitutoyo Service Center.
- Each part of the gage is sealed up, and therefore must not be disassembled. If any part is disassembled, the rated performance will not be obtained. Do not absolutely disassemble the gage.

## 5. Gage Output Signal Specifications

### 1) Pin assignments and signals

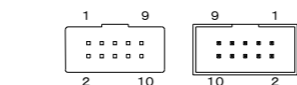

• Applicable receptacle on the external device side  
Sumitomo 3M : V Low-Proheader  
Model:7610-5002XX or equivalent

| Pin No. | Signal    | In/Out | Description  |
|---------|-----------|--------|--|
| 1       | GND       | —      | Signal ground  |
| 2       | DATA      | Out    | Measurement data-output terminal                                     |
| 3       | CK        | Out    | Synchronized clock-output terminal                                   |
| * 4     | N.C.      | —      | Unused   |
| 5       | REQ       | In     | Input terminal for data transmission request<br>From external device |
| * 6     | ORIG      | In     | Absolute origin setup signal input terminal                          |
| * 7     | N.C.      | —      | Unused   |
| * 8     | N.C.      | —      | Unused   |
| * 9     | +5V       | —      | Power supply terminal(+5V $\pm$ 10%)...Note2                         |
| * 10    | GND(F.G.) | —      | Frame ground   |

Note 1: \* indicates pin assignment dedicated only to this instrument  
Other pin assignments are based on specifications common to Digimatic outputs(10-pin square connector specifications).

Note2: Consumption current of this instrument: I<sub>dd</sub>=20mA max.

## 2) Electrical specifications

### ●Output terminal type: CK, DATA ●Input terminal type: REQ, ORIG

N-ch open drain Pull-up CMOS input  
Max. output current: 400 $\mu$ Amax (At VoL = 0.4V)  
Internal power supply voltage: V<sub>dd</sub>=1.35 to 1.65V  
Output withstand voltage: -0.3 to 7V Pull-up resistance: R<sub>1</sub>=10 to 100k $\Omega$   
"H" level input voltage: V<sub>IH</sub>=1.1Vmin.  
"L" level input voltage: V<sub>IL</sub>=0.3Vmax.

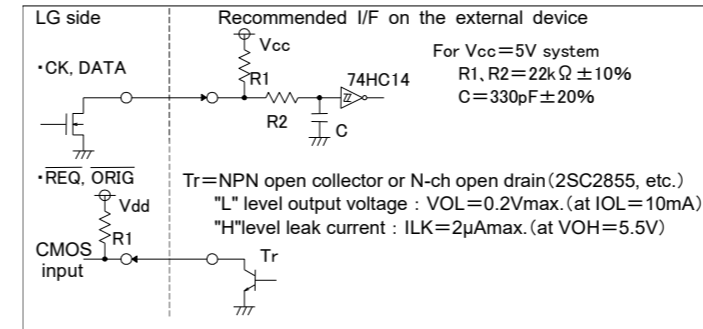

Since the power voltage differs between the gage side and an external device side, absolutely use an open collector or open drain circuit. Do not use a CMOS output, etc.

## 3) Data format

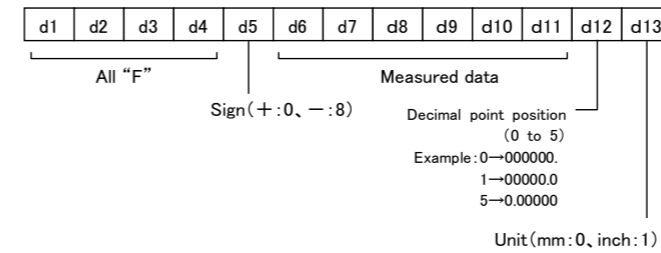

- Each piece of measurement data consists of 13 digits (52 bits) as 4 bits=1 digit.
- The data is outputted sequentially, starting from d1 to d13. Also, each digit is outputted sequentially from LSB to MSB.
- Measurement data is outputted sequentially from MSB to LSD.
- A sign, measurement data, decimal point position, and unit are outputted as a BCD in positive logic (0 = L, 1 = H).

## 4) Timing chart

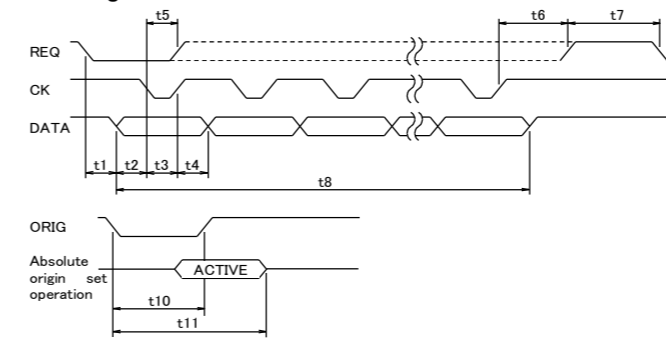

| Symbol | min.        | max.        | Symbol | min.        | max. |
|--------|-------------|-------------|--------|-------------|------|
| *t1    | 30 $\mu$ s  | 95ms        | *t7    | 100 $\mu$ s | —    |
| t2     | 15 $\mu$ s  | —           | *t8    | —           | 30ms |
| t3     | 100 $\mu$ s | —           | *t10   | 1.5s        | —    |
| t4     | 100 $\mu$ s | —           | *t11   | —           | 4s   |
| t5     | 0 $\mu$ s   | —           |        |             |      |
| *t6    | —           | 100 $\mu$ s |        |             |      |

Note1: \* indicates a specification dedicated only to this instrument. All other Digimatic output specifications are common to all models.

Note2: Read the data when the CK is at the L level.

Note3: While setting the absolute origin (during t11), do not input the REQ signal.

Note4: If t5, t6 and t7 are satisfied and REQ is continuously input, an output is obtained from LGD at intervals of approximately 95ms.

Note5: Start inputting the ORIG and REQ in approximately 2 or 3 seconds (estimated time for built-in circuitry/sensor stabilization) after turning on the power.

## IMPORTANT

If this linear gage is used with the gage cable close to the power lines of other devices, it will result in a gage malfunction. Be sure to separate the gage cable from the power lines.

## 6. Maintenance

### 1) Replacing the contact point

Detach or attach the contact point by pinching it with a key spanner, etc.

### 2) Replacing the rubber boot

Preventive replacement before being damaged is recommendable.

(The rubber boot is available as an optional accessory.)

- Remove the old rubber boot, then eliminate the dust and dirt in the grooves (part A) or the stem and spindle.

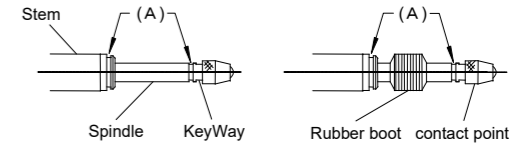

- Insert a rubber boot between the stem and contact point, directing the greater inside diameter end to the stem.

- Apply a small amount of silicone adhesive to the grooves (part A), and seal both ends of the rubber boot.

## IMPORTANT

If the adhesive is applied to the spindle slider, the spindle will not slide properly. Great care must be exercised.

## 7. Specifications

| Order No.                       | 575-303   | 575-313                                   |
|---------------------------------|---|---|
| Model                           | LGS-1012P   | LGS-1012PE                                |
| Measuring range                 | 12.7mm  | .5"                                       |
| Resolution                      | 0.01mm  | .0005"                                    |
| Accuracy(at 20°C)*1             | 0.015mm   | .0006"                                    |
| Stem diameter                   | $\phi$ 8mm  | $\phi$ 9.52mm=3/8" DIA                    |
| Contact point                   | $\phi$ 3carbide ball<br>(Thread:M2.5x0.45)  | $\phi$ 3carbide ball<br>(Thread:#4-48UNF) |
| Protection level*2              | IP66 (Apply only for gage head)   |   |
| Measuring force                 |   |   |
| Contact point downward          | 2N or less  |   |
| Contact point horizontal        | 1.8N or less  |   |
| Contact point upward            | 1.6N or less  |   |
| Positional sensor               | Capacitance-type absolute linear encoder  |   |
| Response speed                  | Infinite; measurement by scanning can not be performed  |   |
| Output method                   | Digimatic output  |   |
| Bearing type                    | Slide-bearing type  |   |
| Output cable length             | 2m (directly wired from the gage)   |   |
| Quantizing error                | $\pm$ 1count  |   |
| Operating temperature(Humidity) | 0 to 40°C (20 to 80%RH, with no condensation)   |   |
| Storage temperature(Humidity)   | -10 to 60°C (20 to 80%RH, with no condensation)   |   |
| Mass                            | 190g  |   |
| Standard accessory              | No.99MBC091B (This instruction manual)  |   |
| CE marking/UKCA marking         | EMC Directive/Electromagnetic Compatibility Regulations:EN IEC 61326-1<br>Immunity test requirement: Clause 6.2 Tabel2<br>Emission limit: Class B |   |

\*1: Quantizing error is not included.

\*2: IP(International Protection) is conformed to IEC60529/JIS C0920

The unit may not be able to maintain resistance to certain types of liquids.

## 8. Optional Accessories

### (must be purchased separately)

| Part name   | Order No. |
|-------------|-----------|
| Rubber boot | No.238774 |

## Mitutoyo Corporation

20-1, Sakado 1-Chome, Takatsu-ku, Kawasaki-shi, Kanagawa 213-8533, Japan

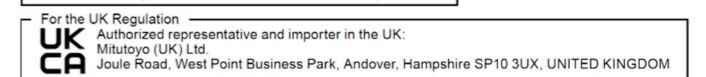
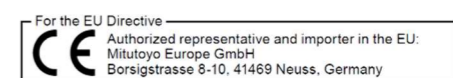

Mitutoyo