

ABS Digimatic Indicator ID-N/ID-B



Safety Precautions

To ensure operator safety, use this product in conformance with the directions, functions and specifications given in this User's Manual.
Use under other conditions may compromise safety.

WARNING Shows risks that could result in death or serious injury.

- Always keep batteries out of reach of children. If swallowed, consult a physician immediately.
- Batteries should never be short-circuited, disassembled, deformed or come in contact with extreme heat or flames.
- If battery alkaline liquid comes in contact with the eyes, flush eyes immediately with clean water and consult a physician. If battery alkaline liquid comes in contact with the skin, flush the exposed area thoroughly with clean water.

CAUTION Shows risks that could result in minor or moderate injury.

Never attempt to charge the primary battery. Never reverse the positive-negative terminals when mounting. Improper battery handling or mounting may cause the battery to explode, cause battery leakage and/or serious bodily injury or malfunctioning.

NOTICE Shows risks that could result in property damage.

- Do not disassemble or modify.
- Large errors will result when used in places with significant temperature fluctuation, due to the thermal expansion of structural components and fixing jigs. Use in places with minimal temperature fluctuation whenever possible. Allow the product to adapt to the ambient temperature when using in a location with a different temperature.
- Do not store the product in a place with high humidity or a lot of dust.
- Firmly screw on the battery compartment cover if the product is used in a place where it is directly exposed to splashes of coolant.
- When mounting the output cable, firmly tighten the fixing screws so that there is no gap.
- Do not apply excessive force or subject to sudden impacts such as falling.
- Be sure to perform origin setting before measurement.
- Remove dust, cutting chips, etc. before and after use.
- Do not write numbers, etc. with an electric pen.
- Do not operate the keys with a pointed object (such as a screwdriver or ballpoint pen).
- Avoid loads in the vertical direction relative to the plunger or usage involving torsion to the plunger.
- This product is shipped without a battery installed. Install a battery before use.
- The battery provided is for confirming the functions and performance of the product. Note that this battery may not last for the entire expected life.
- When disposing of batteries, follow local laws, regulations, etc.
- Malfunctions or damage due to depleted battery, etc. are not covered by the warranty.

Key icon operation

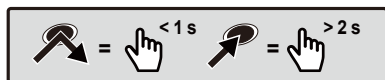

Contents

1. Names and Dimensions of Components	Page 1
2. Installing (Replacing) the Battery	Page 2
3. Setup	Page 2
4. Power ON/OFF	Page 3
5. Operation Modes	Page 3
6. Switching Measurement Systems	Page 3
7. Measurement Method	Page 3
8. Setting Parameters	Page 5
9. Precautions after Use	Page 6
10. Replacing the Rubber Boot (Optional)	Page 6
11. Error Displays and Countermeasures	Page 6
12. Input/Output Functions	Page 6
13. Specifications	Page 7
14. Accessories (Optional)	Page 7
15. Off-Site Repairs (Subject to Charge)	Page 7

1. Names and Dimensions of Components

■ ID-N

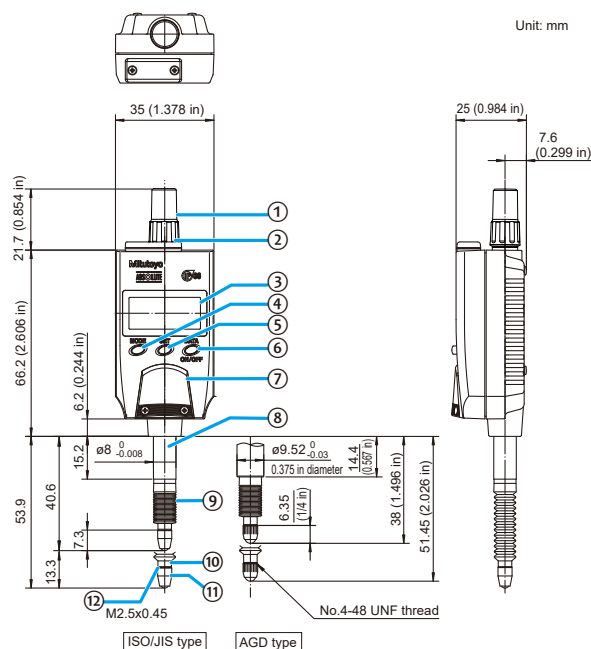

Unit: mm

■ ID-B

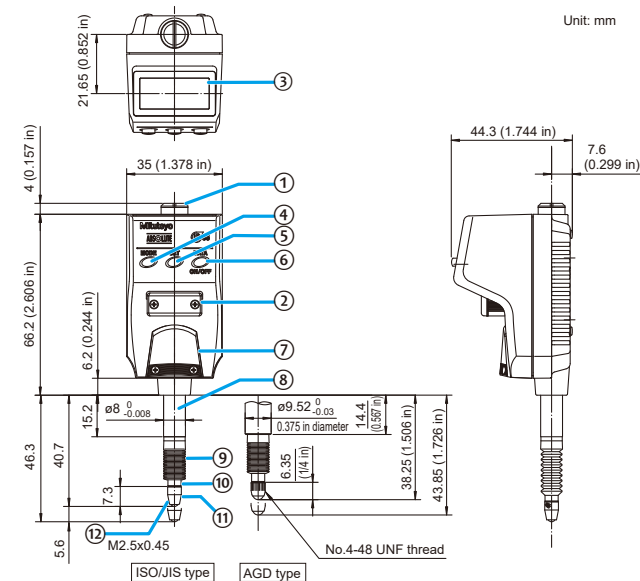

Unit: mm

- | | |
|-------------------------------|-----------------------------|
| ① Cap | ⑦ Battery cover |
| ② Output connector (with cap) | ⑧ Stem |
| ③ Display (LCD) | ⑨ Rubber boot |
| ④ [MODE] key | ⑩ Plunger |
| ⑤ [SET] key | ⑪ Contact point |
| ⑥ [DATA ON/OFF] key | ⑫ Contact point joint screw |

■ Display (LCD)

With LCD Rotation function disabled

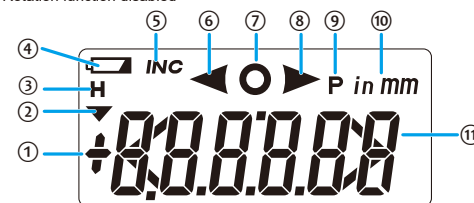

With LCD Rotation function enabled

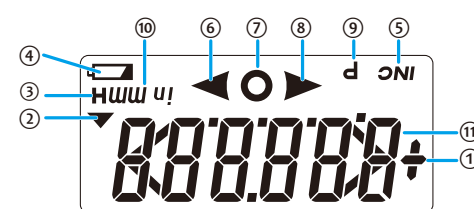

- | | |
|---|---|
| ① Sign display | ⑦ Tolerance judgment result display (OK) |
| ② Reverse counting display | ⑧ Tolerance judgment result display (+NG) |
| ③ Hold display | ⑨ Preset display |
| ④ Low voltage display | ⑩ Unit display |
| ⑤ INC display | ⑪ Measured value display |
| ⑥ Tolerance judgment result display (-NG) | (tolerance judgment enlarged display) |

2. Installing (Replacing) the Battery

NOTICE Shows risks that could result in property damage.

- The product may display an error or malfunction if the battery cover is not mounted correctly.
- If the product will be out of use for 3 months or more, remove the battery and store it separately, to prevent damage to the product due to battery fluid leakage.



- Be sure to use SR44 (silver oxide button battery, part No. 938882) for the battery.
- Use the provided 0-size screwdriver (Part No. 05CZA619) when mounting/removing the fixing screws, and tighten with a torque of 5 cN·m to 10 cN·m or so.

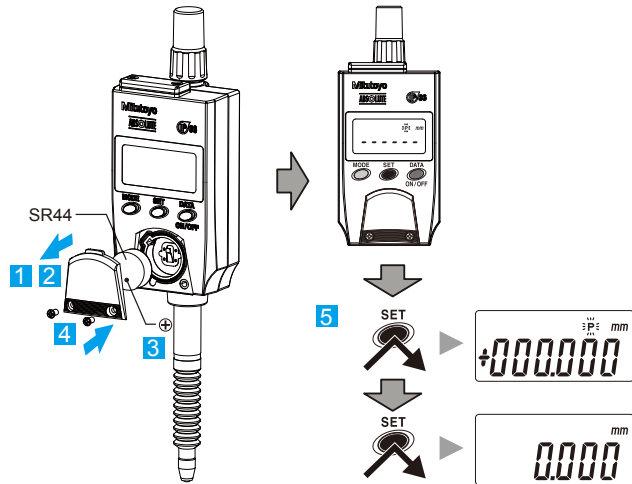

- 1 Use the provided Phillips screwdriver to remove the fixing screws.
- 2 Remove the battery cover.
If replacing a battery, remove the existing battery.
- 3 Insert a new battery with the "+" symbol facing outward.
- 4 Mount the battery cover and tighten the fixing screws.
⇒ [----] display lights up.
- 5 Press the [SET] key.
⇒ [P] blinks and origin setting (presetting) begins.

Tips

- If origin setting (presetting) does not begin even after pressing the [SET] key, reinstall the battery.
- All settings are cleared when the battery is removed. All settings must be reconfigured.

Key icon operation



3. Setup

1) Mounting to a stand, jig, etc.

NOTICE Shows risks that could result in property damage.

- Whenever possible, avoid fixing the stem directly with a set screw, etc.
- The plunger may not be able to move smoothly if the screw is tightened with a tightening torque of 300 cN·m or more to secure the stem.

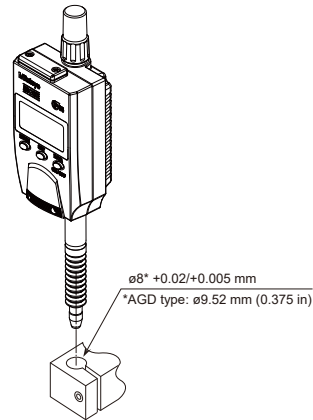

Tips

When mounting the product to a stand or jig, use the stem or a back with lug (optional). If using the stem, use a slotted holder with a *ø8 G7 (+0.005 to +0.02) mm holder.
* AGD type: ø9.52 mm (0.375 in)

2) Mounting the lug (optional)

A lug (optional) can be used to secure the product.
Part No. 21EZA145 (for ISO/JIS type)
Part No. 21EZA146 (for AGD type)



When mounting, do not remove the fixing screws for the back. Doing so could negatively affect the waterproofing performance.



Mount the lug with the four fixing screws provided (M2 x 4, Part No. 21ESA047). While the mounting holes are not threaded, the provided fixing screws are tapping screws and can be used without tapping.

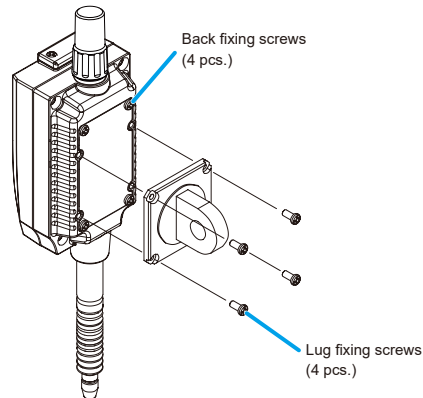

■ ID-N

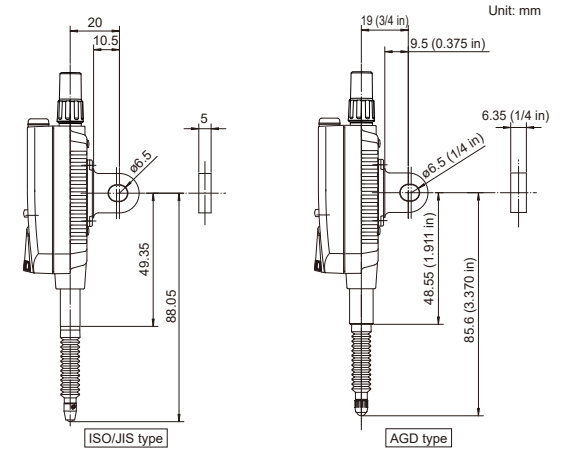

■ ID-B

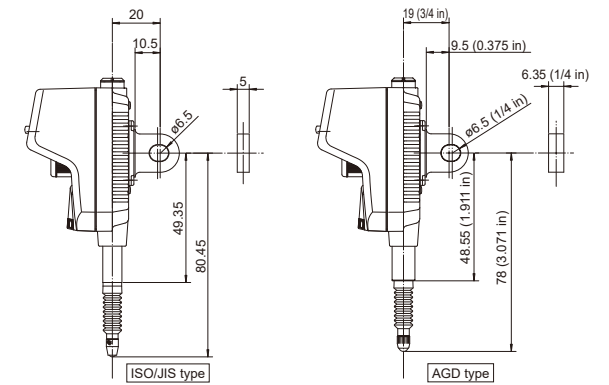

3) Mounting the lifting knob (optional)

Part No. 21EZA105 (for ISO/JIS type)
Part No. 21EZA150 (for AGD type)

NOTICE Shows risks that could result in property damage.

- Using the product while the lifting knob is not secured firmly may damage internal components or the workpiece.
- If not mounting a lifting knob, always mount the original screw on the plunger top end. Otherwise internal components or the workpiece may be damaged.
- If the cap is removed, dust, mist, or other substances could enter the gap between the plunger and main body, causing malfunction or failure. Avoid using the product in very dusty or misty environments.

- 1 Rotate the cap counterclockwise to remove it from the product.
- 2 Fix the plunger, using pliers padded with a rag, etc., so that it does not turn, and then remove the screw (M2.5/No. 4-48UNF) at the top end of the plunger. During this process, push the plunger upward.
- 3 Mount the lifting knob on the top end of the plunger.

Tips

Store the removed cap and screw to prevent loss.

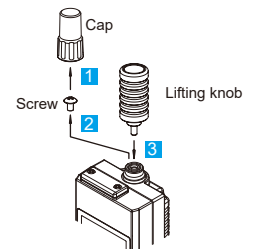

4) Contact point replacement

NOTICE Shows risks that could result in property damage.

When replacing the contact point, turn the contact point while fixing the plunger. Otherwise, the product may be damaged.



Mount and remove the contact point with a rag and 2 pairs of pliers (one for fixing the plunger) as shown in the figure.

! When fixing the plunger, secure the outer side of the rubber boot to prevent damage. If the rubber boot is damaged, it could negatively affect the dust-proofing/waterproofing performance.

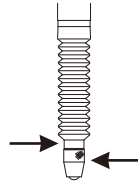

Tips

- Changing the contact point may cause changes in external dimensions and measuring force, or restrictions on the possible measurement directions.
- Errors due to the contact point (perpendicularity of flat contact point, center runout of roller contact point, etc.) are added to the measurement accuracy.
- Various contact points are available as options. Refer to the Measuring Instruments Catalog for details.

4. Power ON/OFF

1) Turning the power on

- 1 Press the [DATA ON/OFF] key.
⇒ Power turns on.

2) Turning the power off

- 1 Press and hold the [DATA ON/OFF] key.
⇒ Power turns off.

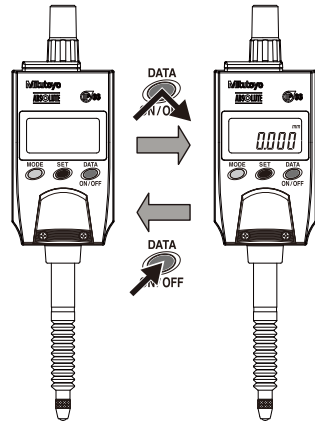

Tips

- The product always starts up in measurement mode when the power is turned on.
- The measurement system when the power is turned on is the same as it was when turned off. (Refer to "6. Switching Measurement Systems" for details about measurement systems.)
- If the power does not turn on even when the [DATA ON/OFF] key is pressed, the battery may be depleted. Replace the battery.
- Turning the power off while making settings will cancel the setting and return the product to the status before setting.

5. Operation Modes

This product is equipped with the following two operation modes.

- **Measurement mode:**
This mode is used for tasks such as normal measurement, tolerance judgment, holding displayed values, and outputting displayed values to an external device.
- **Parameter setting mode:**
This mode is used to set parameters.
Refer to "8. Setting Parameters" for details on how to set parameters.

6. Switching Measurement Systems

Measurement mode includes the following two measurement systems.

- **Absolute measurement (ABS):** Measures the distance from a set (preset) origin. The origin can be set to any desired value to support a wide range of workpieces.
- **Incremental measurement (INC):** Zeros the displayed value with the master and measures a difference between the master and a workpiece.

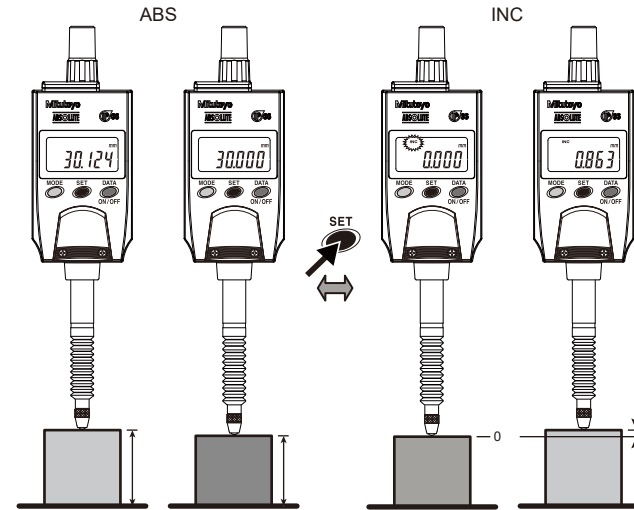

- 1 Press and hold the [SET] key.
⇒ Measurement system switches.

Tips

The displayed value is simultaneously reset to zero when switching the measurement system from ABS to INC.

Key icon operation

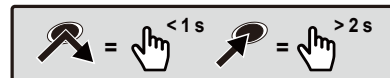

7. Measurement Method



- Large measurement errors will result when used in environments with significant temperature fluctuation, due to the thermal expansion of components and fixing jigs. Use in places with minimal temperature fluctuation whenever possible. Allow the product to adapt to the temperature when moved to an environment with a different temperature.
- When setting or presetting the origin, be sure to lift the plunger at least 0.2 mm above the bottom dead center.

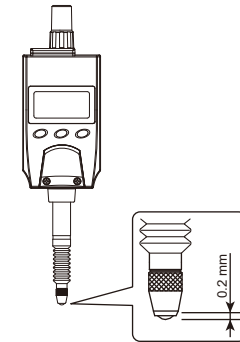

1) For absolute measurement (ABS)

For absolute measurement, first set (preset) the origin using the following procedure, and then measure.

- 1 Confirm that the product is in absolute measurement.
⇒ If in incremental measurement, switch the measurement system to absolute measurement. (Refer to "6. Switching Measurement Systems" for details.)
- 2 Starting origin setting (presetting)
Press the [SET] key.
⇒ [P] will blink and the previous preset value will be displayed.
⇒ Continue to step 4-3 if not changing the preset value.
- 3 Setting the preset value

- 1 Press and hold the [SET] key.
⇒ The sign will blink and the preset value can be changed.
- 2 Press the [MODE] key to change the sign.
⇒ Each time the [MODE] key is pressed, it will switch the sign between "+" and "-".
- 3 Press the [SET] key.
⇒ The sign is confirmed and the neighboring digit blinks.
- 4 Press the [MODE] key to change the number.
⇒ Each time the [MODE] key is pressed, it will switch values in the order of "0→1→2...→9→0".
- 5 Press the [SET] key.
⇒ The number is confirmed and the neighboring digit blinks.
⇒ Press the [SET] key to skip over the digit.
Repeat steps 4 and 5 above until the numbers for all digits are confirmed.
⇒ Confirming the last digit will cause [P] to blink.

Tips

- If the preset value is incorrect, press and hold the [SET] key and redo from step 3.
- The held displayed value can be replaced with the preset value. (Refer to "3) Holding the displayed value (if not connected to an external device)".)

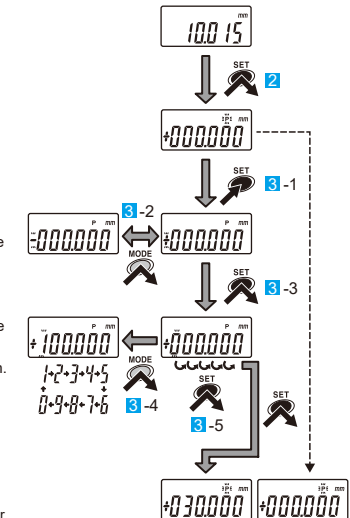

4) Setting the origin (origin point)

- 1 Set the master to use for reference.
- 2 Press the [SET] key.
 - ⇒ Registered preset value is displayed (example: 30.000 mm).
- 3 Confirm the preset value, and then press the [SET] key.
 - ⇒ The preset value is set as the origin, and the product returns to absolute measurement mode.

5) Replace the master with the workpiece and perform absolute measurement.

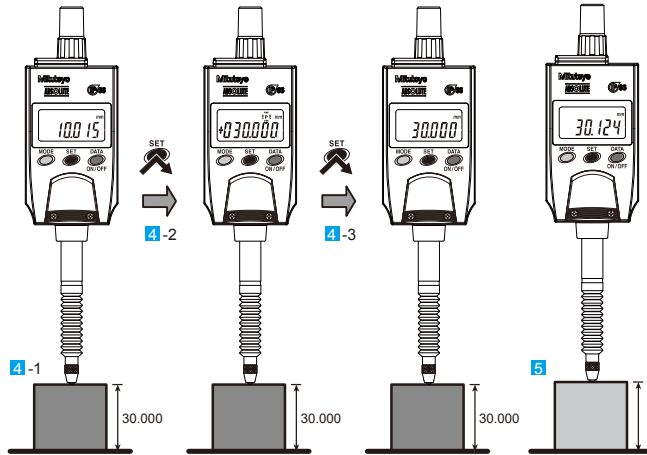

Tips

- The set preset value and origin are retained even when the power is turned off. However, the preset value is cleared when replacing the battery and must be reset.
- The preset value is automatically converted when the unit system or resolution is changed. In this case, however, a conversion error may be produced. It is therefore recommended to check the preset value after changing the unit system or resolution.
- Press and hold the [MODE] key to stop or cancel settings midway through.

2) For incremental measurement (INC)

Incremental measurement is used to measure the dimensional difference between the master (used as reference) and a workpiece.

- 1 Confirm that the product is in incremental measurement.
 - ⇒ If in absolute measurement, switch the measurement system to incremental measurement. (Refer to "6. Switching Measurement Systems" for details.)
- 2 Set the master to use for reference.
- 3 Press the [SET] key.
 - ⇒ Displayed value is reset to zero.
- 4 Replace the master with the workpiece and perform incremental measurement.

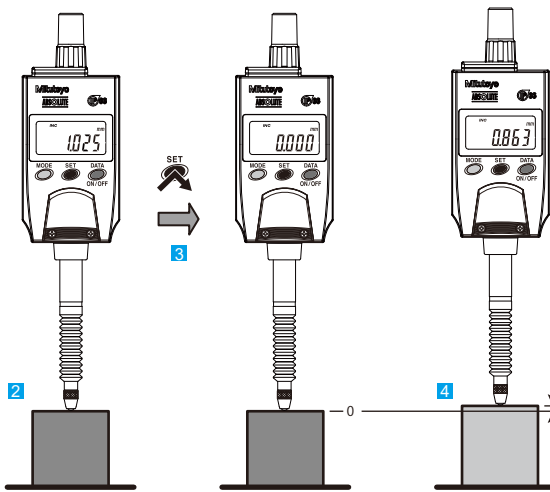

3) Holding the displayed value (if not connected to an external device)

The displayed value can be held (fixed).

- 1 Press the [DATA ON/OFF] key.
 - ⇒ [H] will appear and the displayed value will be held (the displayed value will be retained even if the workpiece is removed).
- 2 Press the [DATA ON/OFF] key while the displayed value is held.
 - ⇒ [H] will go out and the held displayed value will be released.

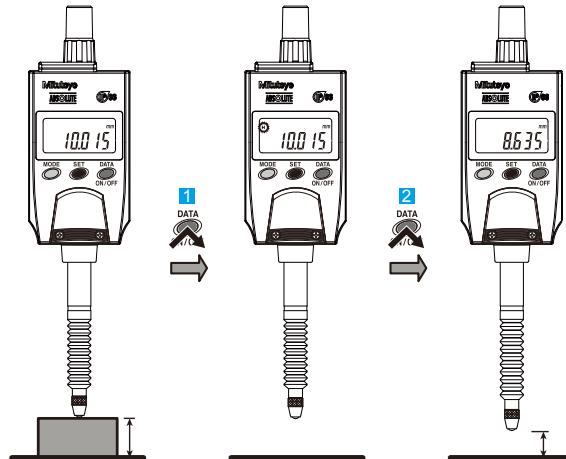

Tips

Press the [SET] key while the displayed value is held to replace it with the preset value.

4) Externally outputting the displayed value (if connected to an external device)

The displayed value is output to the connected external device. This function is enabled only when connected to an external device.

- 1 Press the [DATA ON/OFF] key while in measurement mode.
 - ⇒ The displayed value is output to the connected external device.

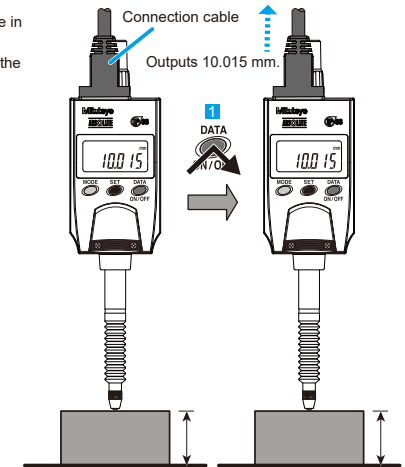

Tips

- Refer to "12. Input/Output Functions" for details on installing connection cable, pin assignments, output data format, and timing chart.
- Carefully read the User's Manual of the data processing device to be connected when using the External Output function and use it accordingly.
- If inputting an output request (REQ) from the connected external device, do so only when the plunger is stopped. If an output request (REQ) is received while the plunger is moving, it may output an incorrect value or data output may not be possible.
- If output requests (REQ) are received over short intervals, data output may not be possible.

Key icon operation



8. Setting Parameters

There are five types of parameter items to set.

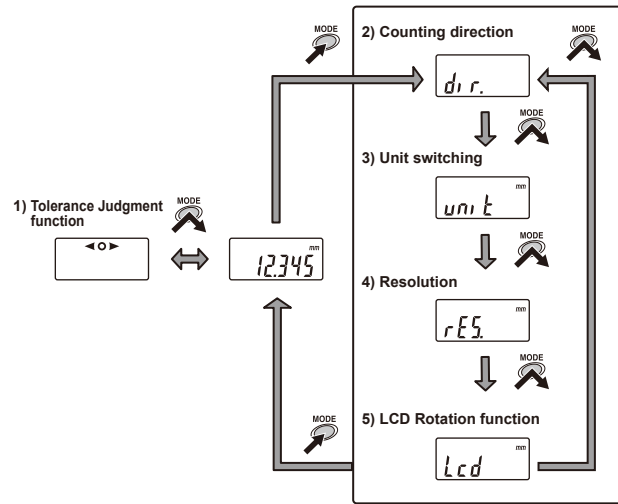

Tips

- Press and hold the [MODE] key to cancel the parameter setting. Note that unconfirmed settings will not be reflected.
- All parameter settings are retained even when the power is turned off. However, they are all cleared when replacing the battery and must be reset.

1) Setting Tolerance Judgment function

The tolerance limit values can be set to provide a GO/NG judgment for the measured value (pass/fail judgment). Tolerance limit values can be set independently for ABS/INC measurement systems.

Normal display (measured value and judgment result)



Enlarged display (judgment result only)



- Confirm that the measurement mode to which the Tolerance Judgment function is applied is selected.
- Entering parameter setting mode
Press the [MODE] key.
⇒ Tolerance Judgment function can be set.
- Setting the measurement result display method
1 Select display method by pressing the [MODE] key.
⇒ Each time the [MODE] key is pressed, it will switch display methods in the order of "A → B → C → Measurement mode".
A: Normal display
B: Enlarged display
C: Display off
2 Press the [SET] key.
⇒ Selection is confirmed.
If "Normal display" or "Enlarged display" was selected:
[▶] blinks and the upper limit can be set.
To skip setting the upper limit, press the [SET] key again (proceed to step 5).
If [OFF] was selected:
Tolerance judgment results are displayed, and the product returns to measurement mode.

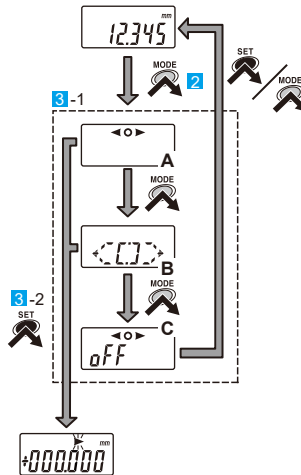

4) Setting the upper limit

- Press and hold the [SET] key.
⇒ The sign will blink and can be changed.
⇒ Continue to step 3 if not changing the sign.
 - Press the [MODE] key to change the sign.
⇒ Each time the [MODE] key is pressed, it will switch the sign between "+" and "-".
 - Press the [SET] key.
⇒ The sign is confirmed and the neighboring digit blinks.
 - Press the [MODE] key to change the number.
⇒ Each time the [MODE] key is pressed, it will switch values in the order of "0 → 1 → 2... → 9 → 0".
 - Press the [SET] key.
⇒ The number is confirmed and the neighboring digit blinks.
⇒ Press the [SET] key to skip over the digit.
Repeat steps 1 and 2 above until the numbers for all digits are confirmed.
⇒ Confirming the last digit will cause [▶] to blink.
 - Press the [SET] key.
⇒ The upper limit is set, [◀] blinks, and the lower limit can be set.
- ### 5) Setting the lower limit
- Set in the same way as the upper limit (step 4).
 - Press the [SET] key.
⇒ Settings are confirmed, and the product returns to measurement mode.

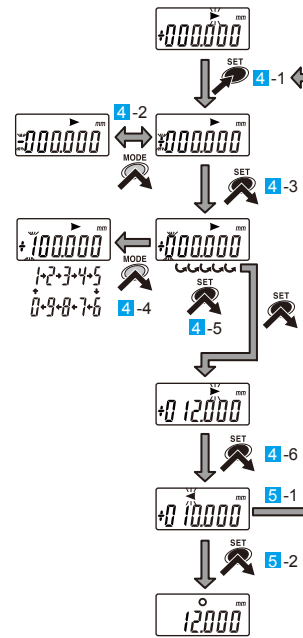

Tips

- If the upper limit is set below the lower limit, the error display [E--E] appears and the set value is cleared. Clear the error display by pressing the [SET] key and amend the settings, starting with the upper limit. (Refer to "11. Error Displays and Countermeasures".)
- The tolerance limit values cannot be set for "normal display" and "enlarged display" separately.
- The tolerance limit values are automatically converted when the unit system or resolution is changed. In this case, however, a conversion error may be produced. It is therefore recommended to check the tolerance limit values after changing the unit system or resolution.
- Press and hold the [MODE] key to stop or cancel settings midway through. Note that unconfirmed settings will not be reflected.
- All settings are retained even when the power is turned off. However, they are all cleared when replacing the battery and must be reset.

Key icon operation

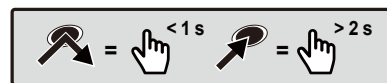

2) Setting counting direction

The counting direction can be set with regard to the plunger movement direction.

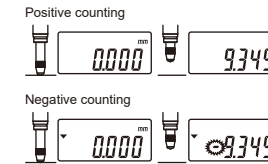

- Entering parameter setting mode
Press and hold the [MODE] key.
⇒ Shifts to parameter setting mode.

- Selecting the parameter item to set
1 Confirm that [dir.] is blinking.
2 Press the [SET] key.
⇒ Counting direction can be switched.

- Setting the counting direction
1 Press the [MODE] key to select the counting direction.

[▼] off: Counts up (positive counting) when the plunger is raised.

[▼] blinking: Counts down (negative counting) when the plunger is raised.

⇒ Each time the [MODE] key is pressed, it will switch the counting direction between up and down.

- Press the [SET] key.
⇒ Settings are confirmed; shifts to next parameter item.

For AGD type:
Proceed to step 3 in "3) Switching unit systems (AGD type only)".

For 0.001 mm models:
Proceed to step 3 in "4) Switching resolution (0.001 mm models only)".

For 0.01 mm models:
Proceed to step 3 in "5) Setting the LCD Rotation function".

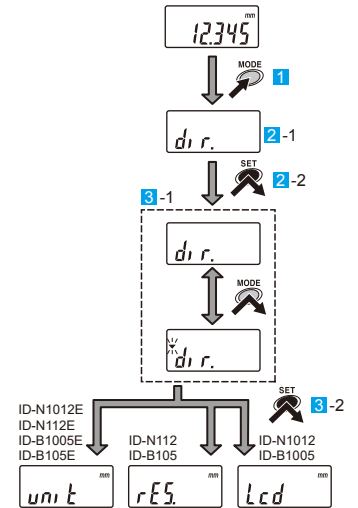

3) Switching unit systems (AGD type only)

- Entering parameter setting mode
Press and hold the [MODE] key.
⇒ Shifts to parameter setting mode.
- Selecting the parameter item to set
1 Confirm that [unit] is blinking.
2 Press the [SET] key.
⇒ Unit display can be switched.
- Setting the unit display
1 Press the [MODE] key to select the unit system.
⇒ Each time the [MODE] key is pressed, it will switch the unit system between "mm" (millimeters) and "in" (inches).
2 Press the [SET] key.
⇒ Settings are confirmed; shifts to next parameter item.
For 0.001 mm models:
Proceed to step 3 in "4) Switching resolution (0.001 mm models only)".
For 0.01 mm models:
Proceed to step 3 in "5) Setting the LCD Rotation function".

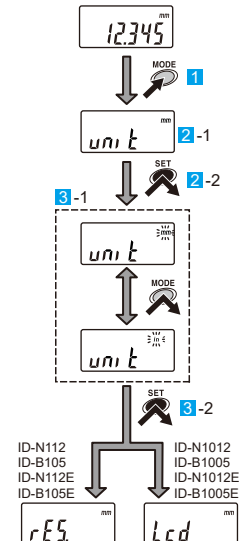

4) Switching resolution (0.001 mm models only)

The resolution setting can be changed for 0.001 mm models only.

- 1 Entering parameter setting mode
Press and hold the [MODE] key.
⇒ Shifts to parameter setting mode.
- 2 Selecting the parameter item to set
1 Press the [MODE] key until [rES.] is displayed.
2 Press the [SET] key.
⇒ Resolution can be switched.
- 3 Setting the resolution
1 Press the [MODE] key to select the resolution.
⇒ Each time the key is pressed, it will switch the value between "0.001 mm" and "0.01 mm".
2 Press the [SET] key.
⇒ Settings are confirmed; shifts to next parameter item. (Proceed to step 2 in "5) Setting the LCD Rotation function".)

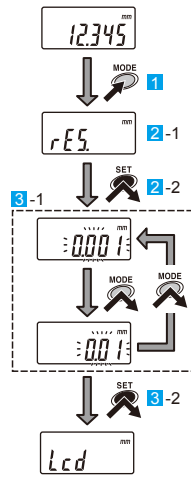

5) Setting the LCD Rotation function

The measured values displayed on the LCD can be rotated 180°.

- 1 Entering parameter setting mode
Press and hold the [MODE] key.
⇒ Shifts to parameter setting mode.
- 2 Selecting the parameter item to set
1 Press the [MODE] key until [Lcd] is displayed.
2 Press the [SET] key.
⇒ LCD Rotation function can be set.
- 3 Setting the LCD display method
1 Select display method by pressing the [MODE] key.
⇒ Each time the [MODE] key is pressed, it will switch the display between "No rotation" and "Rotation".
2 Press the [SET] key.
⇒ Settings are confirmed; shifts to next parameter item (proceed to step 2 in "2) Setting counting direction").

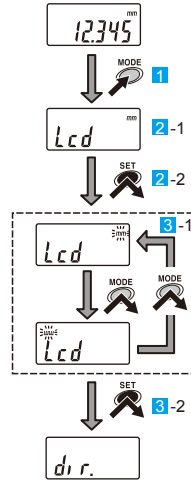

Tips

The LCD Rotation function is executed as soon as parameter setting finishes and the product returns to measurement mode.

Key icon operation



9. Precautions after Use

- Lightly wipe off dirt on this product with a lint-free soft cloth. Do not use organic solvents such as detergents, thinner or benzene.
- If the product is to be out of use for 3 months or more, remove the battery before storage. Liquid leakage from the battery may damage the product.
- Do not store the product in a place with a high temperature or humidity, or a lot of dust or oil mist.

10. Replacing the Rubber Boot (Optional)

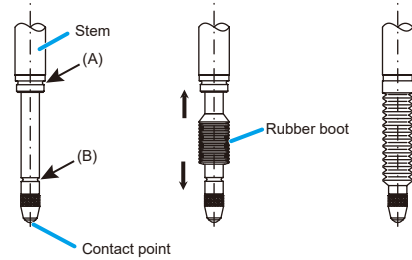

- 1 Remove the old rubber boot and wipe away dust or oil from the stem groove (A) and plunger groove (B) with alcohol, etc.
- 2 Put the rubber boot on the plunger so that the rubber boot end with the larger bore is on the stem side, and then set the rubber boot in between the stem and the contact point.
- 3 Lightly apply a small amount of room temperature curing silicone adhesive to grooves (A) and (B). At this time, be careful not to apply silicone adhesive to the plunger sliding surface.
- 4 Pinch the top end of the rubber boot with a tool such as flat tip tweezers and fit it into stem groove (A).
- 5 Attach the bottom end of the rubber boot to plunger groove (B) by pressing manually.
- 6 Wipe away excess adhesive with a clean cloth.

Tips

Prompt replacement of the rubber boot is recommended if using the product in an environment frequently exposed to water or oil (in order to prevent damage).

11. Error Displays and Countermeasures

Error Display	Causes and Countermeasures
ABS Synthesis Error 	Although this may be momentarily displayed while the plunger is moving, it is a normal artifact of internal processing. If it occurs while the plunger is not moving, the internal sensor has failed. In this case, repair is required: please contact the agent where you purchased the product or Mitutoyo sales representative.
Low Battery Voltage 	Battery is depleted. Replace with a new battery.
Display Overflow 	The measured value exceeds the number of digits that can be displayed. • In ABS, press the [SET] key to enter the origin setting and reset the preset value. • In INC, press the [SET] key at the appropriate position and set to zero. • Press and hold the [MODE] key to enter parameter setting mode and change the resolution to an appropriate value. (0.001 mm models only)
Sensor Contamination Detection Error 	A sudden change in temperature may create condensation on the detector, or it may be contaminated by other sources. • Turn the power off and allow the product to adapt to the temperature for about 2 hours. • If it does not recover after adapting to the temperature, repair is required: please contact the agent where you purchased the product or Mitutoyo sales representative.

Error Display	Causes and Countermeasures
Preset Value Setting Error (Normal Measurement) 	The preset value for normal measurement exceeds the number of digits that can be displayed. • Press and hold the [SET] key to return to preset value settings, and then reset to an appropriate value. • Press the [SET] key to return to measurement mode, and then switch to an appropriate resolution in parameter setting mode. (0.001 mm models only)
Tolerance Limit Value Setting Error 	The upper limit is set below the lower limit. • Press the [SET] key to return to the tolerance limit value settings, and then reset so that the upper limit is above the lower limit.
Upper Limit Setting Error 	The upper limit exceeds the number of digits that can be displayed. • Press and hold the [SET] key to return to upper limit value settings, and then reset to an appropriate value. • Press the [SET] key twice to enter resolution settings, and then switch to an appropriate resolution. (0.001 mm models only)
Lower Limit Setting Error 	The lower limit exceeds the number of digits that can be displayed. • Press and hold the [SET] key to return to lower limit value settings, and then reset to an appropriate value. • Press the [SET] key to enter resolution settings, and then switch to an appropriate resolution. (0.001 mm models only)

12. Input/Output Functions

1) Externally outputting the displayed value

The displayed value can be output to a device supporting Digimatic output format by connecting the product and the external device with a connection cable (optional). An optional external display, external printer, PC, etc. can be connected.

- 1 Press the [ON/OFF] key to turn off the product.
- 2 Use the provided Phillips screwdriver to remove the fixing screws from the output connector cap.
- 3 Remove the output connector cap and gasket.
- 4 Attach the connector gasket to the connection cable and insert it.
- 5 Tighten with the fixing screws removed in step 2.
- 6 Connect the other end of the connection cable to the external device.

■ ID-N1012, ID-N112

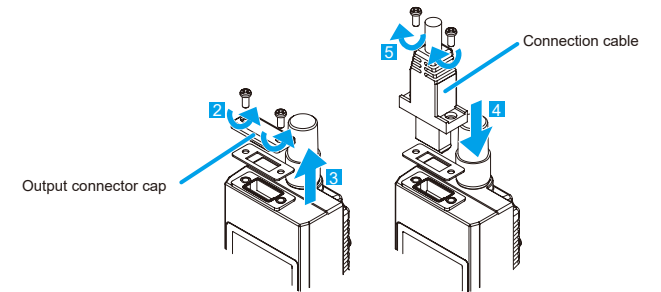

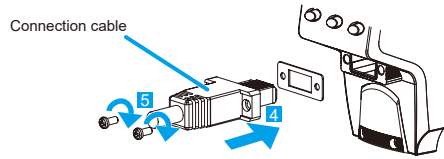

! Use the provided 0-size screwdriver (Part No. 05CZA619) when mounting/removing the fixing screws, and tighten with a torque of 5 cN·m to 10 cN·m or so.

Tips

- Four types of connection cables (optional) are available for this product: Part No. 21EAA194 (1 m), 21EAA190 (2 m), 21EAA210 (1 m, with external zero setting terminal), and 21EAA211 (2 m, with external zero setting terminal).
- When connecting a connection cable, pay attention to the connector direction as you insert it.
- Store the removed output connector cap to prevent loss.
- Always install the output connector cap if a connection cable is not used.
- Connection cables with external zero setting terminals have an I/O connector whose GND and ORIG terminals are branched. These cables can be used to short either terminal, allowing the preset value to be recalled or zero-set externally. Use in combination with a commercially available push switch or similar.

2) I/O connector

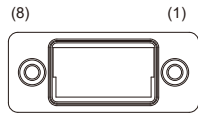

Pin No.	Signal	I/O
(1)	GND	-
(2)*1	DATA	O
(3)*1	CK	O
(4)*2	REQ	I
(5)*3	ORIG	I
(6)*1	RD	O
(7)	N.C.	-
(8)	F.G.	-

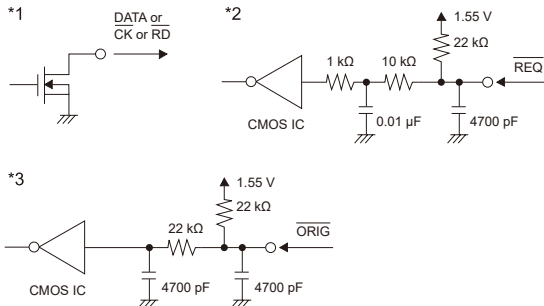

3) Output data format

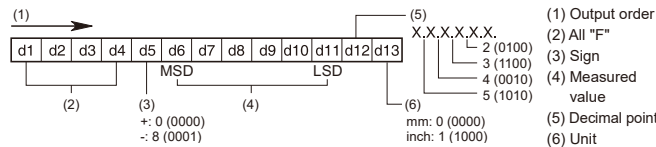

4) Output timing chart

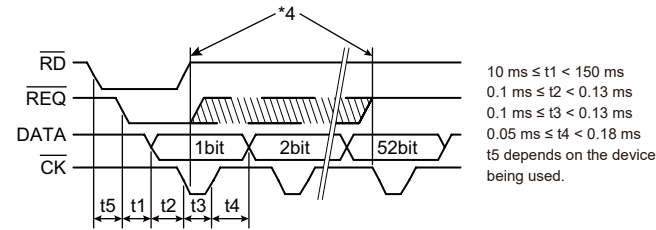

*4 Keep REQ at Low until CK is output. Return it to High before the final CK output is completed (52nd bit).

5) Input timing chart

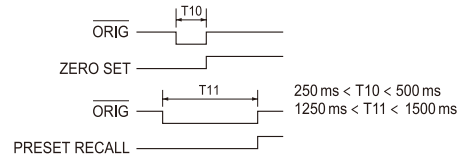

13. Specifications

■ Individual Specifications

Model	ID-N1012	ID-N112	ID-B1005	ID-B105
Code No.	543-570	543-575	575-580	543-585
Measuring range	12.7 mm		5.08 mm	
Resolution	0.01 mm	0.001 mm/ 0.01 mm	0.01 mm	0.001 mm/ 0.01 mm
JIS/ISO	Error of indication (MPE)	Partial measuring range P_{MPE} *1	0.02 mm	0.003 mm
		Total measuring range E_{MPE} *1	0.02 mm	0.003 mm
	Hysteresis H_{MPE} *1		0.02 mm	0.002 mm
	Repeatability R_{MPE} *1		0.01 mm	0.002 mm
Stem	ø8 mm			
Contact point	Carbide (joint screw M2.5 x 0.45), part No. 901312 (provided as standard)			
Measuring force (MPL)	≤ 2.5 N		≤ 2 N	
Measurement direction	All directions			
Mass	130 g			

Model	ID-N1012E	ID-N112E	ID-B1005E	ID-B105E
Code No.	543-571	543-576	543-581	543-586
Measuring range	12.7 mm/0.5 in		5.08 mm/0.2 in	
Resolution	0.01 mm 0.0005 in	0.001/0.01 mm 0.00005/ 0.0005 in	0.01 mm 0.0005 in	0.001/0.01 mm 0.00005/ 0.0005 in
JIS/ISO	Error of indication (MPE)	Partial measuring range P_{MPE} *1	0.02 mm	0.003 mm
		Total measuring range E_{MPE} *1	0.02 mm	0.003 mm
	Hysteresis H_{MPE} *1		0.02 mm	0.002 mm
	Repeatability R_{MPE} *1		0.01 mm	0.002 mm
ASME	Overall *1*2		±0.001 in	±0.0001 in
	Hysteresis *1		0.001 in	0.0001 in
	Repeatability *1		0.0005 in	0.0001 in
	Stem	ø9.52 mm (0.375 in)		
Contact point	Carbide (joint screw No. 4-48UNF), part No. 21BZB005 (provided as standard)			
Measuring force MPL	≤ 2.5 N		≤ 2 N	
Measurement direction	All directions			
Mass	130 g			

■ Common Specifications

Protection level *3	IP66 equivalent *4
CE marking/ UKCA marking	EMC Directive/Electromagnetic Compatibility Regulations: EN IEC 61326-1 Immunity test requirement: Clause 6.2 Table 2 Emission limit: Class B RoHS Directive/The Restriction of the Use of Certain Hazardous Substances in Electrical and Electronic Equipment Regulations: EN IEC 63000
Power supply	SR44 silver oxide battery x 1 (part No. 938882)
Battery life *5	About 7000 hours in continuous service, approximately 1 year of normal use
Scale	Electrostatic capacitance type absolute linear encoder
Response speed	Unlimited (unavailable for scanning measurement)
Data output	Digimatic code out
Temperature range	Operation: 0 °C to 40 °C, storage: -10 °C to 60 °C
Standard accessories	SR44 (for function verification, 1 pc.), User's Manual/warranty, 0-size screwdriver (Part No. 05CZA619)

*1: During normal measurement at 20 °C.

*2: Overall magnification and linearity

*3: The protection level (IP: International Protection) is based on IEC 60529/JIS C 0920.

*4: Values are for factory default conditions.

*5: The battery life varies depending on usage times and conditions. The above values are guidelines.

14. Accessories (Optional)

- Lifting knob (for ISO/JIS type): Part No. 21EZA105
- Lifting knob (for AGD type): Part No. 21EZA150
- Lug (for ISO/JIS type): Part No. 21EZA145
- Lug (for AGD type): Part No. 21EZA146
- Rubber boot (for ID-N/oil resistant (NBR)): Part No. 21EAA423
- Rubber boot (for ID-N/durable (silicone)): Part No. 238774
- Rubber boot (for ID-B/oil resistant (NBR)): Part No. 21AAB562
- Rubber boot (for ID-B/durable (silicone)): Part No. 21EAA212
- Connection cable: Part No. 21EAA194 (1 m, flat straight waterproof type)
- Connection cable: Part No. 21EAA190 (2 m, flat straight waterproof type)
- Connection cable with external zero setting terminal: Part No. 21EAA210 (1 m, flat straight waterproof type)
- Connection cable with external zero setting terminal: Part No. 21EAA211 (2 m, flat straight waterproof type)

*For accessories (optional) other than the above, refer to the Measuring Instruments Catalog.

15. Off-Site Repairs (Subject to Charge)

Off-site repair (subject to charge) is required in the case of the following malfunctions. Please contact the agent where you purchased the product or Mitutoyo sales representative.

- Poor plunger operation
- Poor accuracy
- [E] is displayed as the last digit when the plunger is stationary
- Abnormal measured value or LCD trouble
- No recovery from [Err C]
- Power will not turn on

*If the fundamental structural components or multiple components need to be replaced, we reserve the right to decline the repair.