



High-Precision Linear Gage LGH Series

LGH-1010-B-EH

LGH-1010C-B-EH

User's Manual - Instructions for use -

Read this document thoroughly before operating the product. After reading, retain it close at hand for future reference.

No. 99MBC122A7

Date of publication: July 1, 2025 (1)



■ Correspondence of product names and model numbers

Product name	Model number
High-Precision Linear Gage	LGH-1010-B-EH
LGH Series	LGH-1010C-B-EH

■ Notice regarding this document





- Mitutoyo Corporation assumes no responsibilities for any damage to the product, caused by its use not conforming to the procedure described in this document.
- Upon loan or transfer of this product, be sure to attach this document to the product.
- In the event of loss or damage to this document, immediately contact a Mitutoyo sales office or your dealer.
- Before operation of the product, thoroughly read this document to comprehend its contents.
- Particularly, for full understanding of information, carefully read "Safety Precautions" and "Precautions for Use" at the outset of this document before using the product.
- The contents in this document are based on the information current as of July 2025.
- No part or whole of this document may be transmitted or reproduced by any means without prior written permission of Mitutoyo Corporation.
- Some screen displays in this document may be highlighted, simplified or partially omitted for convenience of explanation. In addition, some of them may differ from actual ones to the extent that no user will misunderstand the functions and operations.
- The corporation, organization and product names that appear in this document are their trademarks or registered trademarks.

©2019-2025 Mitutoyo Corporation. All rights reserved.



Conventions Used in Manuals

Conventions used in Mitutoyo's User's Manual are roughly divided into three types (safety reminders, prohibited and mandatory actions, and referential information and locations). Moreover, these conventions include general warnings and specific warnings. Specific warning symbols are provided with concrete pictograms inside of them.

■ Safety reminder conventions and wording warning against potential hazards

	Indicates an immediately hazardous situation which, if not avoided, will result in serious injury or death.
	Indicates a potentially hazardous situation which, if not avoided, could result in serious injury or death.
	Indicates a potentially hazardous situation which, if not avoided, may result in minor injury.
	Indicates a potentially hazardous situation which, if not avoided, may result in property damage.
	Alerts the user to a specific hazardous situation that means "Caution, risk of electric shock".

■ Conventions and wording indicating prohibited and mandatory actions

	Indicates concrete information about prohibited actions.
	Indicates concrete information about mandatory actions.
	Indicates that grounding needs to be implemented.

■ Conventions and wording indicating referential information or referential locations

Tips Indicates referential information such as that for when the operating methods and procedures which are printed in these sentences are to be applied to specific conditions.



Indicates referential locations if there is information that should be referred to in this document or an extraneous User's Manual.

E.g.: For details about XX, see  "1.2 Part Names and Functions" (page 2).

Safety Precautions

Read these Safety Precautions thoroughly before operating the system to use it properly.

These safety precautions include such information as to prevent an injury to the operator and other persons or damage to property. Be sure to observe the precautions.

WARNING



Do not remove the cover or disassemble the product. Otherwise you may be subject to electric shock, and there is a risk of breakage or fire due to a short circuit caused by metallic powders that have gotten inside the product.

Precautions for Use

■ Product applications and handling

● This product is a measuring instrument.

Do not use it for any purposes other than measuring.

● This is an industrial product.

Do not use this product for any purposes other than industrial applications.

● This product is precision equipment.

- Handle this product with care. Do not apply excessive shock or force to any of the parts during operation.
- Be sure to mount the gage head securely.
- When handling the gage head, hold it by a part near the stem. Do not hold by the spindle/rubber cap or cable.

■ Installation environment

This product is designed for indoor use. To ensure optimal performance for this precision equipment, take the following conditions into account when installing this product.

- **Vibration**
Install this product in an environment where it will be subject to minimal vibration. Using this product in a place with significant vibration for an extended period of time may result in malfunction of the precision components. If using this product in a place with significant vibration is unavoidable, lay a vibration-proof rubber sheet, etc., under this product in order to reduce the vibration.
- **Dust**
Dust in the installation site negatively affects the electrical components in the Display. Install this product in an environment where it will be subject to minimal dust.
- **Sunlight**
If this product is exposed to direct sunlight, the heat will cause deformations in the main body, negatively affecting its operation. If installing this product in an environment that is exposed to direct sunlight, such as near a window, is unavoidable, protect it from the sunlight by curtaining it off, etc.
- **Ambient temperature, humidity**
Avoid using it in a place that is subject to sudden changes in temperature or humidity.

When using this product in the following environments, take necessary shielding measures.

- In locations subject to electric noise, such as from static electricity
- In locations subject to strong electric fields
- In locations near power supply lines/power lines
- In locations where it may directly exposed to chips, cutting fluids, water, etc.
- In locations that may be exposed to radiation
- In locations that may be exposed to corrosive gas

■ Maintenance

Gently wipe dirt off of the product with a soft, tightly woven cloth. Do not use organic solvents such as thinner or benzine.

■ Power source



- Turn off the power switch after use.
- Do not connect the AC adapter to high-current power used by machine tools or large CNC measuring instrument.
- If you use a commercial power source, use a power cable measuring 30 m or shorter for the instrument, and connect the instrument to the power source one-to-one.



- Use only a power source for this product that is rated at 12 V to 24 V and an output current of 1 A or more. Never use this power source with other electric equipment that runs at a high voltage and/or large current.
- Avoid outdoor wiring.



- Be sure to connect this product to ground.
- Connect the AC adapter to a grounding three-slot outlet.

Electromagnetic Compatibility (EMC)

This product complies with the EMC Directive and the UK Electromagnetic Compatibility Regulations; however, if this receives electromagnetic interference that exceeds these requirements, it will be out of warranty and require appropriate measures.

Export Control Compliance

This product falls into the Catch-All-Controlled Goods and/or Catch-All-Controlled Technologies (including Programs) under Category 16 of Appended Table 1 of Export Trade Control Order or under Category 16 of Appended Table of Foreign Exchange Control Order, based on Foreign Exchange and Foreign Trade Act of Japan.

If you intend re-export of the product from a country other than Japan, re-sale of the product in a country other than Japan, or re-providing of the technology (including Programs), you shall observe the regulations of your country.

Also, if an option is added or modified to add a function to this product, this product may fall under the category of List-Control Goods, List-Control Technology (including Programs) under Category 1 - 15 of Appended Table 1 of Export Trade Control Order or under Category 1 - 15 of Appended Table of Foreign Exchange Control Order, based on Foreign Exchange and Foreign Trade Act of Japan. In that case, if you intend re-export of the product from a country other than Japan, re-sale of the product in a country other than Japan, or re-providing of the technology (including Programs), you shall observe the regulations of your country. Please contact Mitutoyo in advance.

Notes on Export to European Countries

When you intend exporting of this product to any of the European countries, it may be required to provide User's Manual(s) in English and Declaration of Conformity in English (in some cases, the official language of the country to be exported). For detailed information, please contact Mitutoyo in advance.

Disposal of Products outside the European Countries

Please follow the official instruction in each community and country.

Disposal of Old Electrical & Electronic Equipment (Applicable in the European Countries with Separate Collection Systems)



This symbol on the product or on its packaging is based on WEEE Directive (Directive on Waste Electrical and Electronic Equipment), and this symbol indicates that this product shall not be treated as household waste.



To reduce the environmental impact and minimize the volume of landfills, please cooperate in reuse and recycle.

For how to dispose of the product, please contact your dealer or the nearest Mitutoyo sales office.

China RoHS Compliance Information

This product meets China RoHS requirements. See the table below.

产品中有害物质的名称及含量

部件名称	有害物质					
	铅 (Pb)	汞 (Hg)	镉 (Cd)	六价铬 (Cr(VI))	多溴联苯 (PBB)	多溴二苯醚 (PBDE)
本体	×	○	○	○	○	○
配件	○	○	○	○	○	○

部件名称	有害物质			
	邻苯二甲酸 二正丁酯 (DBP)	邻苯二甲酸 二异丁酯 (DIBP)	邻苯二甲酸 丁基苄酯 (BBP)	邻苯二甲酸 二(2-乙基己)酯 (DEHP)
本体	○	○	○	○
配件	○	○	○	○

本表格依据 SJ/T 11364 的规定编制。

○: 表示该有害物质在该部件所有均质材料中的含量均在 GB/T 26572 规定的限量要求以下。

×: 表示该有害物质至少在该部件的某一均质材料中的含量超出 GB/T 26572 规定的限量要求。



环保使用期限标识是根据《电器电子产品有害物质限制使用管理办法》以及《电器电子产品有害物质限制使用标识要求(SJ/T11364-2024)》制定的,适用于中国境内销售的电子电气产品的标识。

电器电子产品只要按照安全及使用说明内容在正常使用情况下,从生产日期算起,在此期限内产品中含有的有毒有害物质不致发生外泄或突变,不致对环境造成严重污染或对其人身、财产造成严重损害。

产品使用后,要废弃在环保使用年限内或者刚到年限的产品,请根据国家标准采取适当的方法进行处置。

另外,此期限不同于质量/功能的保证期限。

Warranty

In the event that this product should prove defective in workmanship or material, within one year from the date of original purchase for use, it will be repaired or replaced, at Mitutoyo's option, free of charge upon its prepaid return to Mitutoyo, without prejudice to the provisions of the Mitutoyo Software End User License Agreement.

If this product fails or is damaged for any of the following reasons, it will be subject to a repair charge, even if it is still under warranty.

- Failure or damage owing to fair wear and tear
- Failure or damage owing to inappropriate handling, maintenance or repair, or to unauthorized modification
- Failure or damage owing to transport, dropping, or relocation of the product after purchase
- Failure or damage owing to fire, salt, gas, abnormal voltage, lightning surge, or natural disaster
- Failure or damage owing to use in combination with hardware or software other than those designed or permitted by Mitutoyo
- Failure or damage owing to use in ultra-hazardous activities

This warranty is effective only where the product is properly installed and operated in conformance with the instructions in this document within the original country of the installation.

EXCEPT AS SPECIFIED IN THIS WARRANTY, ALL EXPRESS OR IMPLIED CONDITIONS, REPRESENTATIONS, AND WARRANTIES OF ANY NATURE WHATSOEVER INCLUDING, WITHOUT LIMITATION, ANY IMPLIED WARRANTY OF MERCHANTABILITY, FITNESS FOR A PARTICULAR PURPOSE, NONINFRINGEMENT OR WARRANTY ARISING FROM A COURSE OF DEALING, USAGE, OR TRADE PRACTICE, ARE HEREBY EXCLUDED TO THE MAXIMUM EXTENT ALLOWED BY APPLICABLE LAW.

You assume all responsibility for all results arising out of its selection of this product to achieve its intended results.

Disclaimer

IN NO EVENT WILL MITUTOYO, ITS AFFILIATED AND RELATED COMPANIES AND SUPPLIERS BE LIABLE FOR ANY LOST REVENUE, PROFIT, OR DATA, OR FOR SPECIAL, DIRECT, INDIRECT, CONSEQUENTIAL, INCIDENTAL, OR PUNITIVE DAMAGES HOWEVER CAUSED AND REGARDLESS OF THE THEORY OF LIABILITY ARISING OUT OF THE USE OF OR INABILITY TO USE THIS PRODUCT EVEN IF MITUTOYO OR ITS AFFILIATED AND RELATED COMPANIES AND/OR SUPPLIERS HAVE BEEN ADVISED OF THE POSSIBILITY OF SUCH DAMAGES.

If, notwithstanding the foregoing, Mitutoyo is found to be liable to you for any damage or loss which arises out of or is in any way connected with use of this product by you, in no event shall Mitutoyo's and/or its affiliated and related companies' and suppliers' liability to you, whether in contract, tort (including negligence), or otherwise, exceed the price paid by you for the product only.

The foregoing limitations shall apply even if the above-stated warranty fails of its essential purpose. BECAUSE SOME COUNTRIES, STATES OR JURISDICTIONS DO NOT ALLOW THE EXCLUSION OR THE LIMITATION OF LIABILITY FOR CONSEQUENTIAL OR INCIDENTAL DAMAGES, IN SUCH COUNTRIES, STATES OR JURISDICTIONS, MITUTOYO'S LIABILITY SHALL BE LIMITED TO THE EXTENT PERMITTED BY LAW.

About This Document

■ Positioning of this document in document map

The manuals for this product and related products are as follows.

● Linear Gage related

LGH-1010-B-EH
LGH-1010C-B-EH
High-Precision Linear Gage
LGH Series
User's Manual (this manual)

● Software related

SENSORPAK
User's Manual

● Other

DP-1VA LOGGER
Digimatic Mini-Processor
User's Manual

■ Intended readers and purpose of this document

● Intended readers

This document is intended for beginners of LGH-series Linear Gages.

The readers is assumed to have been familiar with basic operation of a PC.

They are also assumed to be able to understand instructions by reading technical drawings.

● Purpose

The objective of this document is to help you to understand the functional outline of the product, functions of each part and how to use.

■ How to read this document

● To measure

Setup of this product and the setting of parameters (if necessary) are required in advance.

☰ "1 Overview" (page 1) to ☰ "3.4 Overview of Parameter Setting" (page 28)

For basic operation, see ☰ "4 Basic Operations" (page 31)

For applied operation, see ☰ "4.7 CEL-Specific Parameter Setting" (page 37) in addition to the above chapter.

● When you do not know the appropriate operation while using this product

Look for the page with the desired operation in the table of contents.

● Terms and definitions

- Internal counter (CEL): Four internal counters (CEL1–CEL4) which perform the origin setup, tolerance judgment, and peak detection for the input counter value.
- BANK: Switchable display unit. BANK1 displays CEL1 and CEL2, BANK2 displays CEL3 and CEL4.
- UNIT: Six input circuits for various measurements.

Tips

For details about BANK, CEL, and UNIT, see ☰ "3.3.1 Internal Structure of the Counter" (page 22).

Contents

Conventions Used in Manuals	i
Safety Precautions	ii
Precautions for Use	ii
Electromagnetic Compatibility (EMC)	iii
Export Control Compliance	iv
Notes on Export to European Countries	iv
Disposal of Products outside the European Countries	iv
Disposal of Old Electrical & Electronic Equipment (Applicable in the European Countries with Separate Collection Systems)	iv
China RoHS Compliance Information	v
Warranty	vi
Disclaimer	vii
About This Document	viii
Contents	x
1 Overview	1
1.1 Main Configurations	1
1.2 Part Names and Functions	2
1.2.1 Gage Head/Signal Connection Cable	2
1.2.2 Counter Front	3
1.2.3 Counter Back	4
1.3 Operation Flow	5
1.4 For Accurate Measurement	6
1.4.1 Precautions for Measurement	6
1.4.2 Effect of Temperature Environment on Accuracy	6
2 Setup	7
2.1 Unpacking and checking items included	7
2.2 Mounting	8
2.2.1 Gage Head	8
2.2.2 Counter	10
2.3 Connections	12
2.3.1 Power Source	12

2.3.2	Connecting Cables for External Equipment	12
2.3.3	Connection Procedure	13
2.4	Operation Check	14
2.5	Checking the Spindle Condition	15
3	Parameter Setting	17
3.1	Procedure for Setting Parameters	17
3.2	List of Parameters	18
3.3	Details of Display Mode	22
3.3.1	Internal Structure of the Counter	22
3.3.2	Details of Display Mode Selection (Parameter Number 06)	24
3.3.3	CEL-Specific Parameters	27
3.4	Overview of Parameter Setting	28
4	Basic Operations	31
4.1	Selection of Display A/B	31
4.2	Switching the Displayed BANK	31
4.3	Zero Setting	32
4.4	Preset	32
4.5	Peak Mode Setting	33
4.5.1	Procedure for Switching Peak Mode	33
4.5.2	Procedure for Clearing Peak Value	33
4.6	Tolerance Value Setting	34
4.6.1	3-Step Tolerance Value Setting (3-Step Tolerance Zone Selection)	34
4.6.2	5-Step Tolerance Value Setting (5-Step Tolerance Zone Selection)	35
4.7	CEL-Specific Parameter Setting	37
4.7.1	Procedure for Setting CEL-Specific Parameters	37
4.7.2	Procedure for Setting Desired Multiplication Factor	37
4.8	Registering, Reading, and Clearing Memory	39
5	External Input/Output Function	41
5.1	Digimatic Output Function (for DP-1VA LOGGER)	41
5.2	USB Communication Function	41
5.3	RS-232C Communication Function	42
5.3.1	Connections	42
5.3.2	Communication Commands	43
5.3.3	Saving and Loading Parameters	44
5.3.4	Timing Chart	46
5.4	RS LINK Function	46
5.4.1	Connections	46

5.4.2	Assignment of CHs	47
5.4.3	RS-232C Data Output Duration	47
5.5	I/O Connector Terminal Function	48
5.5.1	Connections	48
5.5.2	Output Function.....	50
5.5.3	Input Function	51
5.5.4	Timing Chart	52
6	Troubleshooting	55
6.1	Troubleshooting.....	55
6.2	Error Messages.....	56
6.2.1	List of Error Codes	56
6.2.2	Error Cancellation Method	58
7	Specifications	59
7.1	Basic Specifications	59
7.2	Outline Dimensional Drawing	60
7.2.1	Gage Head/Signal Connection Cable	60
7.2.2	Counter	61
7.3	Option.....	62
	SERVICE NETWORK	App-1

1 Overview

This section describes product features and part names.

1.1 Main Configurations

This product is a high-resolution, high-precision length measuring instrument included in the high-end series of our Linear Gage products. Be sure to use it in combination with the supplied EH Counter (dedicated to LGH).

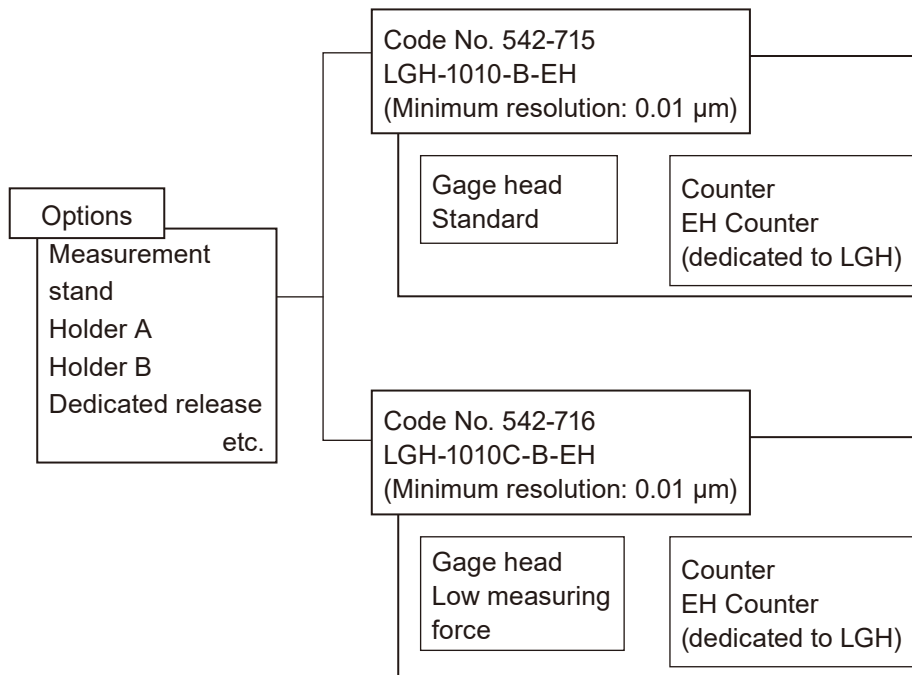

For details on the functions of the supplied counter, see "4 Basic Operations" (page 31).

1.2 Part Names and Functions

1.2.1 Gage Head/Signal Connection Cable

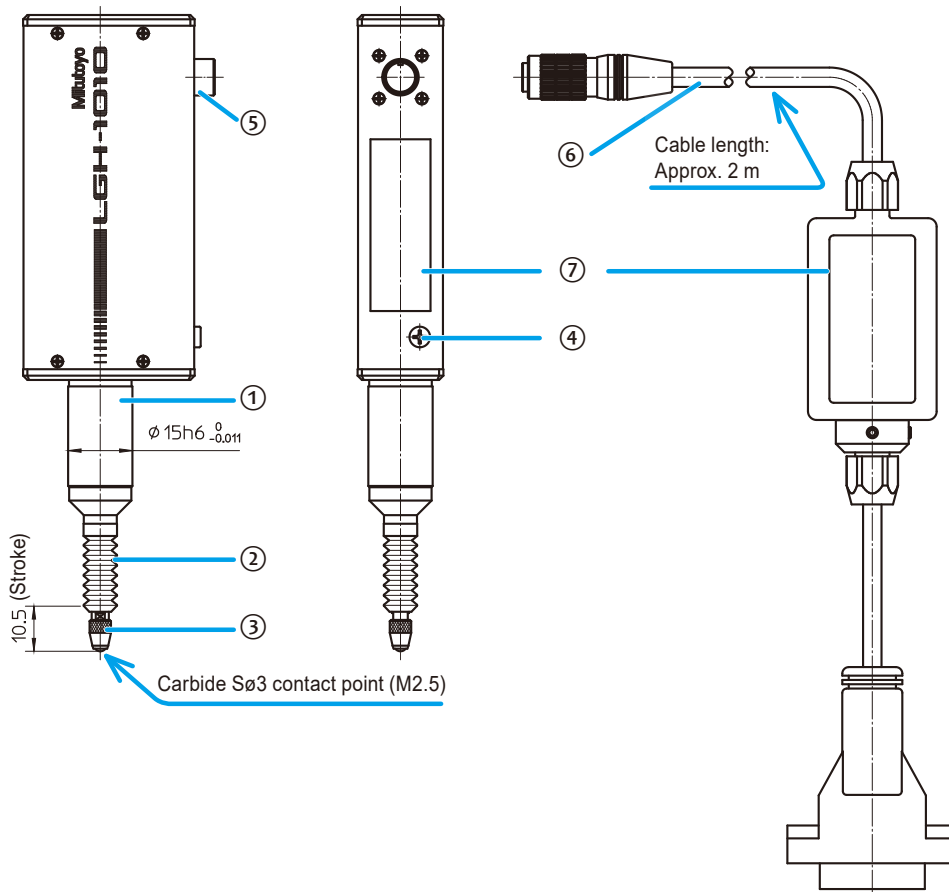

No.	Name	Notes
①	Stem	
②	Spindle/rubber cap	LGH-1010C-B-EH does not have a rubber cap.
③	Contact point	Part No. 901312
④	Release mount screw	
⑤	Connection cable connector	
⑥	Signal connection cable	Detachable
⑦	Serial label	

Tips

The gage head and the signal connection cable have the same serial number as the counter.

1.2.2 Counter Front

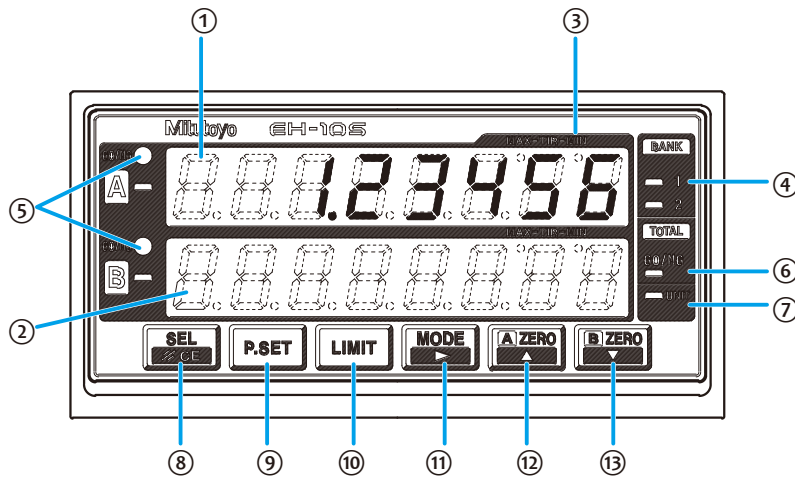

No.	Name	Description
①	Ach (upper display)	Displays the counter value from INPUT A (gage input connector).
②	Bch (lower display)	Displays the peak, speed, or other value from INPUT A (gage input connector) if assigned (nothing by factory default).
③	Peak indicator	Indicates the Peak-mode type.
④	BANK indicator	Indicates the currently selected BANK number (fixed to BANK1 by factory default). For details about BANK, see "4.2 Switching the Displayed BANK" (page 31).
⑤	GO/NG indicator	Indicates the result of the tolerance judgment.
⑥	Total judgment indicator	Indicates the result of the total tolerance judgment by color.
⑦	UNIT indicator	<ul style="list-style-type: none"> Blinks while a HOLD signal is being input when the I/O connector is connected. Lights when an E unit has been selected for the corresponding parameter.
⑧	[SEL] key	<ul style="list-style-type: none"> Switches between Ach (upper display) and Bch (lower display) (fixed to BANK1 by factory default). Cancels an error.
⑨	[P.SET] key	Sets a Preset value. Tips When setting a parameter, this sets the parameter number.
⑩	[LIMIT] key	Sets the tolerance value.
⑪	[MODE] key	Sets Peak mode. Tips When setting the tolerance, preset, or optional constant value, this moves the current input digit from left to right.
⑫	[A_ZERO] key	Sets the current value in Ach (upper display) to 0. Tips <ul style="list-style-type: none"> When setting a parameter, this advances the set value. When setting the tolerance, preset, or optional constant value, this increases the value of the selected digit.

No.	Name	Description
⑬	[B_ZERO] key	Sets the current value in Bch (lower display) to 0. Tips When setting the tolerance, preset, or optional constant value, this decreases the value of the selected digit.

1.2.3 Counter Back

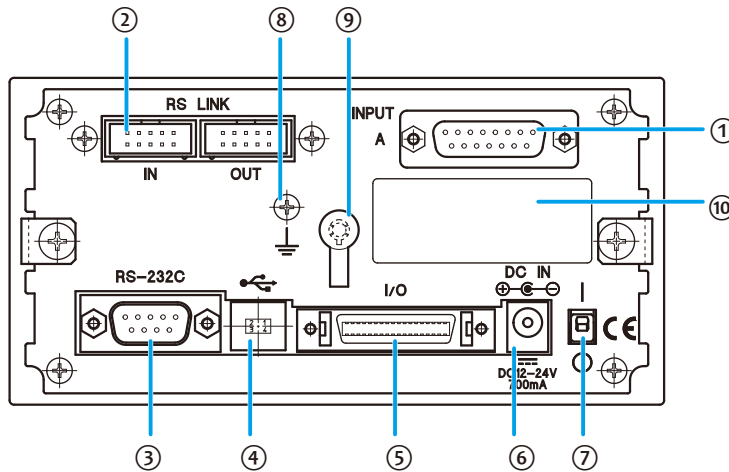

No.	Name	Description
①	INPUT A (gage input connector)	For connecting the signal connection cable.
②	RS LINK connector (also used for printer output)	For connecting an RS LINK connection cable. Also used for the SENSORPAK dongle and for the Digimatic output.
③	RS-232C connector	For connecting an RS-232C connecting cable.
④	USB connector	For connecting a USB connecting cable.
⑤	I/O connector	For connecting an I/O connecting cable.
⑥	DC jack	For connecting the AC adapter.
⑦	Power switch	For turning the power on and off.
⑧	Grounding terminal	For connecting a grounding wire.
⑨	Cable clamp	For securing the power cable.
⑩	Serial label	The serial number is stated. The serial number of this counter is the same as those of the gage head and the signal connection cable.

Tips

- After connecting the power cable, secure with the cable clamp to prevent it from falling.
- The counter (EH Counter) supplied together is dedicated to LGH. Some specifications are different from those of the standard model in our catalog.
- You cannot purchase the counter alone.
- If calibration or repair is required, send the entire set of the gage head, the signal connection cable, and the supplied counter for calibration or repair. We will not service any one of them separately.

1.3 Operation Flow

The basic operation flow is explained below.

Do not omit the operations enclosed with a solid line. Perform the operations enclosed with a dashed line as necessary.

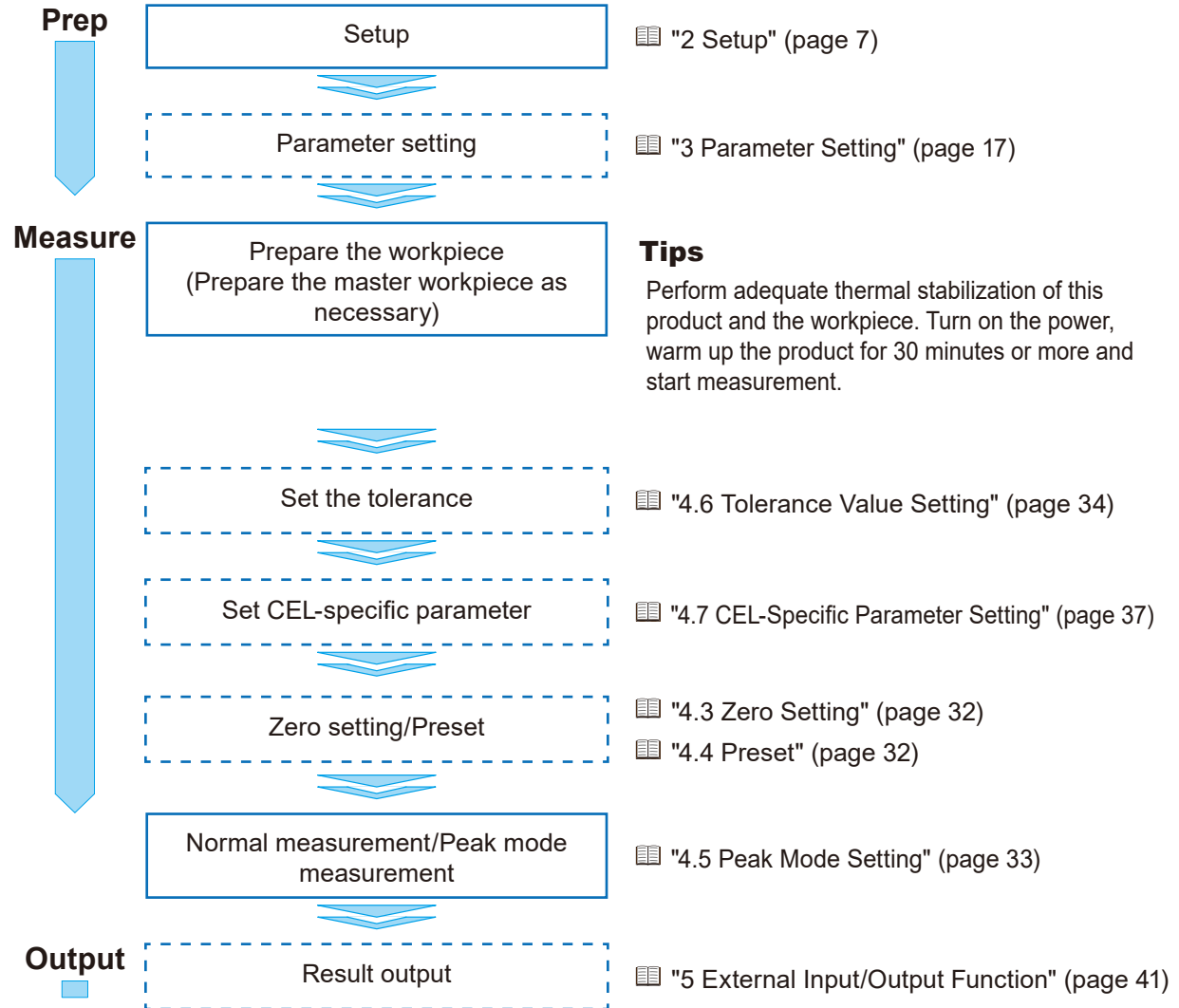

1.4 For Accurate Measurement

1.4.1 Precautions for Measurement



- For accurate measurement, turn on the power, warm up the product for 30 minutes or more and start measurement.
- Be sure to perform adequate thermal stabilization of this product and the workpiece.
- Wipe off the tip of the contact point and the measuring surface to remove dust or dirt before measuring.
- This product does not guarantee accuracy in a range of 0.2 mm from the bottom dead center (spindle in the state protruded most). Lift the spindle 0.2 mm or higher from the bottom dead center when performing Zero setting and preset setting.



A steep level difference may cause a miscount or error. Fully consider the measuring method.

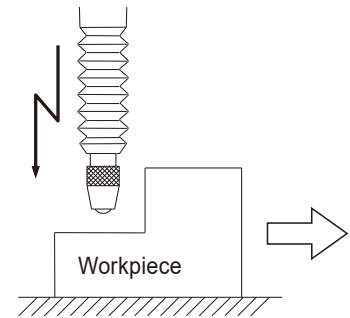

1.4.2 Effect of Temperature Environment on Accuracy



The prescribed accuracy may not be obtained when the product is used at a temperature other than 20 °C. Pay particular attention to the temperature environment.

2 Setup

2.1 Unpacking and checking items included

When unpacking for the first time, check that the following components are contained in the box.

Name	Quantity	Part No.
LGH gage head	1	-
Signal connection cable	1	-
EH Counter (dedicated to LGH)	1	-
Spanner (for replacing the contact point)	1	538610
Rubber foot	4	-
Stand (for EH Counter)	1	-
Washer (for EH Counter)	6	-
AC adapter	1	357651
AC adapter power cable (for use in Japan and other countries)	1	02ZAA000
DC plug (MP-121M)	1	214938
Inspection report	1	-
User's Manual (this document)	1	99MBC122J (Japanese)
		99MBC122A (English)
Warranty	1	-

NOTICE

The LGH gage head, signal connection cable, and EH Counter should have the same serial number. Please make sure that they have the same serial number. Connecting parts with different serial numbers may lead to gage failure, and accuracy cannot be guaranteed.

2.2 Mounting

2.2.1 Gage Head

■ Contact point replacement procedure

Various optional special contact points and extender rods for the dial indicators are available.

⚠ CAUTION

A sharp tipped contact point may cause injury. Be extremely careful in handling when replacing and using it.

NOTICE

When replacing the contact point, use the supplied spanner and do not apply a strong turning or lateral force to the spindle. Doing so may cause damage or malfunction of the spindle.

Tips

- A new contact point may change the external dimensions and measuring force, and the measuring direction may be limited.
- Depending on the shape, use of a contact point other than those supplied may cause errors to accumulate.

1 Remove the gage head from the stand.

2 Set the supplied spanner to the spanner catch at the tip of the spindle (see the figure below) to lock the rotation of the spindle.

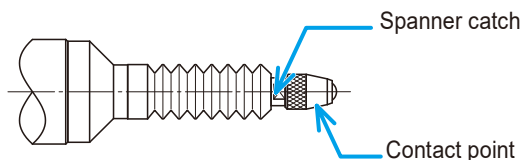

3 Use pliers over a soft cloth to pinch the contact point to protect the contact point and remove it.

4 Attach the contact point in reverse order of removal.

Tips

- The recommended tightening torque is 0.5 N · m.
- After attaching the contact point, make sure that it is not loose.
- For the contact points of the dial indicator, see the General Catalog.

■ Procedure for mounting to the stand (optional) or fixture

- 1 Loosen the fixation screw on the dedicated stand (optional) or other device.
- 2 Insert the stem into the gage mounting hole.

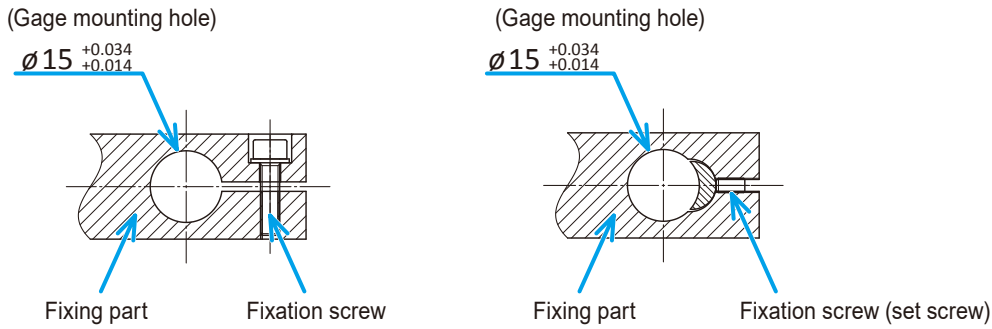

Tips

The above diagrams show examples of how to make a fixation part of the gage head.

- 3 Tighten the fixation screw to secure the gage.



Process the gage mounting hole to be parallel to the measurement direction. A tilted gage will result in a measurement error.

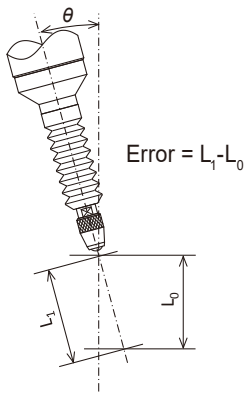

NOTICE

- To secure the gage, use a tightening torque of approximately 0.5 N · m. Overtightening the stem may cause malfunction or failure.
- When measuring by moving the gage head, make sure that the cable will not be strained and no excessive force will be applied to the gage main body. It may cause damage.

For the dedicated stand and other options, see "7.3 Option" (page 62).

■ Procedure for mounting the release (optional)

- 1 Unscrew the release mounting screw on the side of the gage body.
- 2 Attach the tip of the dedicated release (optional).

NOTICE

If the release is not used, put the factory-mounted release mounting screw in place. Dust entering the screw hole will cause failure.

For the release (optional), see  "7.3 Option" (page 62).

2.2.2 Counter

■ Procedure for mounting to a panel

- 1 Cut a rectangular opening in the panel for mounting the counter.

Width (mm)	Height (mm)	Panel thickness (mm)
138.5–139	68.3–68.7	1.0–3.2

- 2 Loosen the fixing bracket screws (see the following figure), and then remove the fixing brackets.

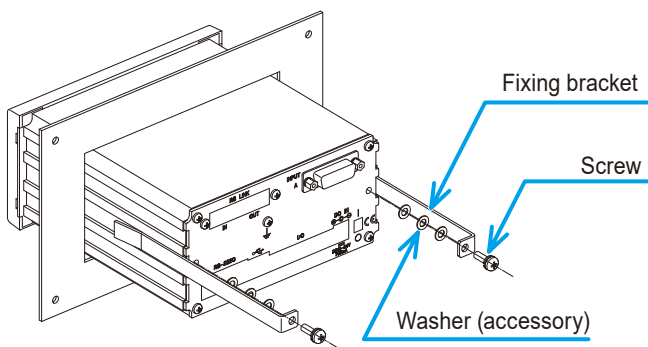

- 3 Insert the counter main body from the front side of the panel.
- 4 From the back of the panel, reattach the fixing brackets which you removed in step 2 to the counter and secure them.

Tips

Refer to the table below and select the number of washers to use according to the thickness of the panel.

Panel thickness (mm)	Number of washers
1.0 to 1.3	0
1.4 to 1.7	1
1.8 to 2.4	2
2.5 to 3.2	3

■ **Placing on a desk**

When the counter is used in a horizontal position on a desk, attach the supplied four rubber feet as shown in the figure below.

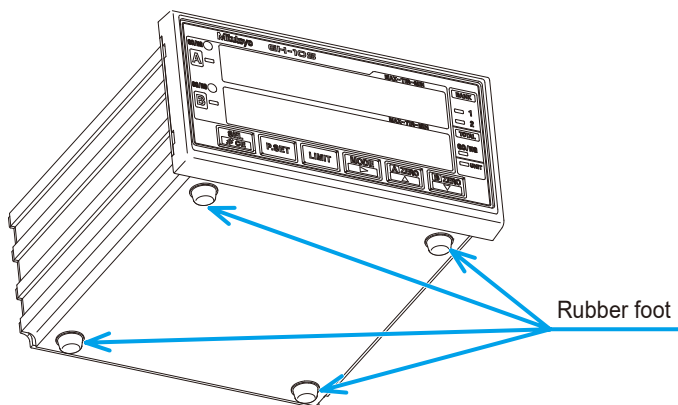

Tips

This product cannot be mounted in a panel with the rubber feet attached.

To use the counter tilted (approx. 10°) on a desk, attach the stand to the counter using the fixing brackets. The procedure for attaching the fixing brackets is the same as for mounting on a panel. Use six washers.

☰ "■ Procedure for mounting to a panel" (page 10)

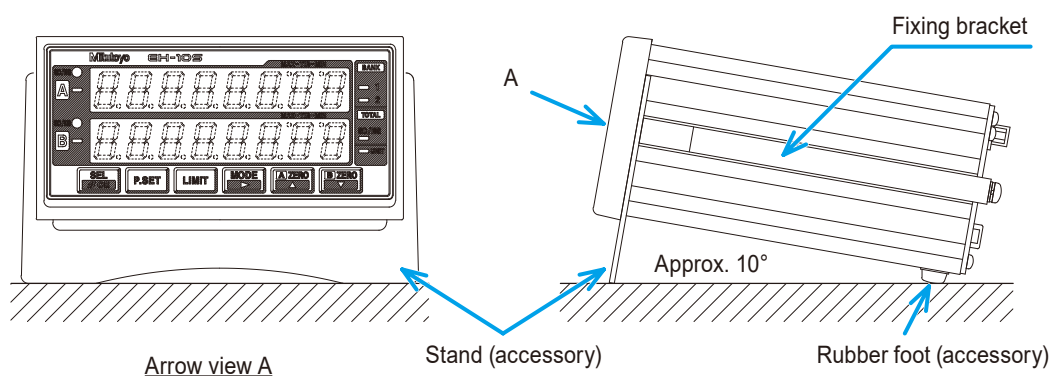

2.3 Connections

2.3.1 Power Source

Use the supplied AC adapter and power cable. If you do not plan to use the supplied AC adapter, prepare a DC power source (voltage: 12 V–24 V, output current: 1 A or more) for each counter. Solder the power cable to the terminals of the supplied DC plug as shown in the figure below.

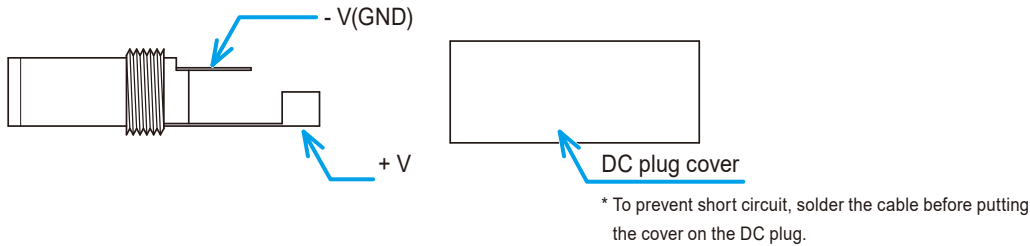

Tips

- The power of the gage head is supplied from the counter.
- If you use a commercial power source, use a power cable measuring 30 m or shorter. Avoid outdoor wiring.



Never use this power source with other electric equipment that runs at a high voltage and/or large current.

2.3.2 Connecting Cables for External Equipment

You must prepare USB, RS-232C, and I/O connector connecting cables for connecting external equipment.

Use a Mitutoyo-approved connecting cable for RS LINK connections.

For details about USB connecting cables, see "5.2 USB Communication Function" (page 41).

For details about RS-232C connecting cables, see "5.3 RS-232C Communication Function" (page 42).

For details about I/O connecting cables, see "5.5 I/O Connector Terminal Function" (page 48).

For details about RS LINK, see "5.4 RS LINK Function" (page 46).

2.3.3 Connection Procedure

NOTICE

The LGH gage head, signal connection cable, and EH Counter should have the same serial number. When using multiple units, connect parts that have the same serial number. Connecting parts with different serial numbers may lead to gage failure, and accuracy cannot be guaranteed.



Make sure that the power switch is off before connecting the gage head to the counter.



Do not run the power cable and the signal connection cable through a cable duct together with other power lines.

Tips

Secure the power cable and connecting cables for external equipment to your equipment with a cable tie, cable holder, etc.



Be sure to connect this product to ground. If this product is not grounded, it will be more susceptible to electrical noise.

■ Procedure for connecting gage head and counter

- 1 Make sure that the gage head, signal connection cable, and counter have the same serial number.
- 2 Connect as illustrated below.

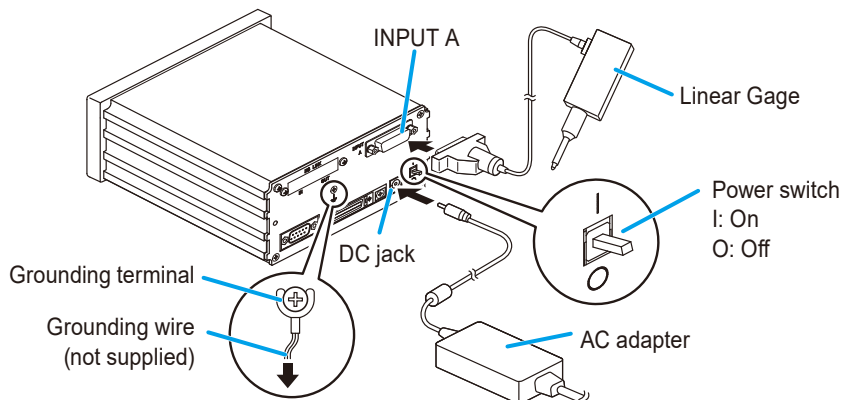

Tips

Tighten the connector screws firmly.

2.4 Operation Check

Check the cable connections with the following procedure to confirm that the connections are correct.

- 1 Turn on the power switch on the back of the counter.

» The counter enters the stand-by state.



- 2 Press [SEL].

» The counter enters the counter value status.



Tips

Pressing [A_ZERO] performs Zero setting for each axis, and then the counter enters the counter value status.

- 3 Check that the counter value is shown on the Display.

- 4 Make sure that the counter value on the counter changes by moving the contact point of the gage head up and down.



- For accurate measurement, turn on the power, warm up the product for 30 minutes or more and start measurement.
- Be sure to perform adequate thermal stabilization of this product and the workpiece.

2.5 Checking the Spindle Condition

A high-precision linear ball bearing is used for the spindle guide of the LGH gage head. Therefore if the spindle is pushed in for a long time, or if the LGH gage head is used for a long time, the contact will not return to the normal bottom dead center.

If the contact point becomes not to reach the reference plane or measuring surface or the display value becomes unstable, make sure the spindle condition by the following procedure.

Tips

The cause is the misalignment of the retainer of the linear ball bearing. This phenomenon is inevitable due to the structure.

In this document, this is called a "retainer misalignment".

■ Procedure for checking and correcting retainer misalignment



Check the retainer misalignment after power-on and before thermal stabilization.

- 1 Turn on the power switch on the back of the counter.

» The counter enters the stand-by state.



- 2 With the contact point free, press [A_ZERO] or [B_ZERO] on the counter.

» The Ach (upper display) or Bch (lower display) is set to zero.

- 3 Lightly and slowly push in the contact point by hand until it stops, and check the counter reading.

Tips

The retainer is normal when the counter reading is 10.5 mm or more.

- 4 If the counter reading is less than 10.5 mm, retainer misalignment has occurred. Slowly pull the tip of the contact point.

» The retracted spindle is pulled out, which corrects the retainer misalignment.

NOTICE

Pull out the spindle to the end position where the movement stops. Be careful not to apply excessive force when pulling out the spindle. Also, avoid turning force on the spindle.

Tips

The pull force should be around 5 N.

- 5 Perform steps 1 to 3 to check for retainer misalignment.

MEMO

3 Parameter Setting

You can set parameters to specify the counter direction, the minimum readout, and other items. Set parameters before you begin measuring.

You also connect the UNIT with the four internal counters called CEL.

For details, see  "4.7.1 Procedure for Setting CEL-Specific Parameters" (page 37).

3.1 Procedure for Setting Parameters

Use Parameter mode to set parameters.

- 1 Turn on the power switch.

» The counter enters the stand-by state.



- 2 Press and hold [P.SET], and then press [A_ZERO].

» The counter enters Parameter mode.

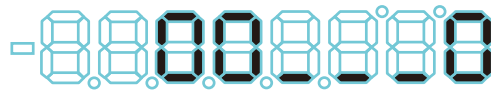

- 3 Press [P.SET] repeatedly to display the parameter number to be modified.

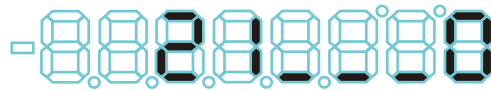

- 4 Press [A_ZERO] repeatedly to modify the value of the parameter.



Tips For an item that can be set for each axis (INPUT A/INPUT B), set the parameter per axis. Set as appropriate for each axis (gage head).





- 5 When the setting of parameters is completed, press and hold [P.SET], and then press [A_ZERO].

» The counter changes to the counter value status.



3.2 List of Parameters

No.	Setting item	Description/Set values (The values in bold indicate initial values.)
00	Parameter mode	<p>Used for setting/saving/loading parameters or setting the optional constant value.</p> <p>0: Setting parameters 1: Setting CEL-specific parameters 2: Setting optional constants 3: Saving parameters 4: Loading parameters</p> <p>Tips For details about saving and loading parameters, see  "5.3.3 Saving and Loading Parameters" (page 44).</p>
01	Parameter initialization	<p>If you set the value of this parameter to 1, the set values for all parameters, except for the unit setting, can be reset to their factory defaults. Once this setting has been enabled, this parameter is initialized to reset the set value to 0 (disable).</p> <p>0: Disabled (one shot) 1: Clear (reset to the initial values)</p>
02	Key protect	<p>Disables key operations to prevent operation errors.</p> <p>0: Normal 1: Disable key inputs</p>
05	(Modification prohibited)	<p>0:- 1: (Not available)</p>
06	Display mode selection	<p>Selects the UNIT (counting method) that is assigned to each CEL. The UNIT to be set can be selected as desired.</p> <p>0: Two-coordinate display 1: Calculation display 2: Dual display 3: Memory display 4: Speed display 5: Optional one-axis display 6: Optional two-axis display 7: Optional four-axis display</p> <p>Tips For details about the display modes, see  "3.3.2 Details of Display Mode Selection (Parameter Number 06)" (page 24).</p>
07	Display at startup	<p>Selects whether to display the standby state or the counter display at startup.</p> <p>0: [- - -] display 1: 0.000</p>

3 Parameter Setting

No.	Setting item	Description/Set values (The values in bold indicate initial values.)
09	Unit system selection	<p>The unit for displayed values can be set to "mm" or "E units". E=1/25.4 mm. After the unit is set, the initial value will not be restored even if the parameters are re-initialized.</p> <p>When the set value is set to 1 or 2, the UNIT indicator turns on.</p> <p>0: mm 1: E 5/100,000 reading 2: E 1/10,000 reading 3: (Not available)</p>
10	Output signal pitch	<p>You can set the output signal pitch of the gage head per axis. Since this product does not allow input for the B-axis (INPUT B), the setting of the B-axis is disabled.</p> <p>0: (Not available) 1: 4 μm 2: (Not available) 3: (Not available)</p>
11	Selection of counter direction	<p>You can set whether the numeral will increase or decrease when the spindle is pushed in, per axis. Since this product does not allow input for the B-axis (INPUT B), the setting of the B-axis is disabled.</p> <p>0: + counting 1: - counting</p>
12	Resolution	<p>You can set the resolution of the gage head per axis. Since this product does not allow input for the B-axis (INPUT B), the setting of the B-axis is disabled.</p> <p>0: (Not available) 1: (Not available) 2: 1 μm 3: 0.5 μm 4: 0.1 μm 5: 0.05 μm 6: 0.01 μm 7: (Not available) 8: (Not available)</p>
13	μm decimal point display	<p>If enabled, the decimal point will be displayed at the μm position.</p> <p>0: Disabled 1: Enabled</p>
14	(Not used)	<p>0:- 1:-</p>
15	Smoothing	<p>Averages the counter value and then displays it. (This reduces fluctuation of the lowest-order digit.) You can specify the number of measurements to average.</p> <p>0: None 1: 16 times 2: 32 times</p>

3 Parameter Setting

No.	Setting item	Description/Set values (The values in bold indicate initial values.)
16	Peak value preset	Sets whether to perform presetting based on the peak value during Peak mode. 0: Disabled 1: Enabled
18	Speed sampling cycle	In Display mode selection, selects the sampling cycle when Speed display is selected. 0: 10 ms 1: 50 ms 2: 100 ms
20	Tolerance/BCD output mode switching *1	Switches between tolerance judgment result output and BCD output. 0: 3-step tolerance 1: 5-step tolerance 2: BCD output
21	BCD output logic *1	Selects whether to use positive logic (0) or negative logic (1) for BCD output. For +000000 output, the values in [] and () indicate the voltages of the DATA line and the sign, respectively. 0: DATA [L] (sign H) 1: DATA [H] (sign L)
24	RS-232C/USB/Digimatic output (for DP-1VA LOGGER) switching *2	Selects which output terminal to use. 0: RS-232C 1: USB 2: DP-1VA LOGGER (printer)
25	Data transfer speed *2	Selects the data transfer speed for RS-232C. 0: 4800 bps 1: 9600 bps 2: 19200 bps
26	Parity check *2	Selects the parity check method for RS-232C. 0: None 1: Odd numbered 2: Even numbered
27	Data bit *2	Selects the length of the data bit for RS-232C. 0: 7 bit 1: 8 bit
28	Output trigger *2	Selects the output trigger method for RS-232C. 0: RS-232 command (normal state) 1: RS-232 command (with channel synchronization function) 2: HOLD trigger OUT

3 Parameter Setting

No.	Setting item	Description/Set values (The values in bold indicate initial values.)
30	Analog output range	Selects the range (resolution range) of the measurement of the analog output. 0: 1999--1999 1: 19990--19990 2: 199900--199900

*1 Modifying this parameter clears the preset and tolerance values.

*2 Turn off the power switch after changing the setting. The setting will be applied when you turn on the power switch again.



Do not change the initial value of Parameter Number 10. Otherwise, no correct counter value will be displayed.

Tips

When "Error90" appears, press the [SEL] key to clear the error, and then enter a valid set value for the parameter.

3.3 Details of Display Mode

3.3.1 Internal Structure of the Counter

This counter has six input circuits (UNIT_A-F) for various measurements and four internal counters (CEL1-4).

Various measurement views are available by changing the connection between UNIT and CEL using the input selector.

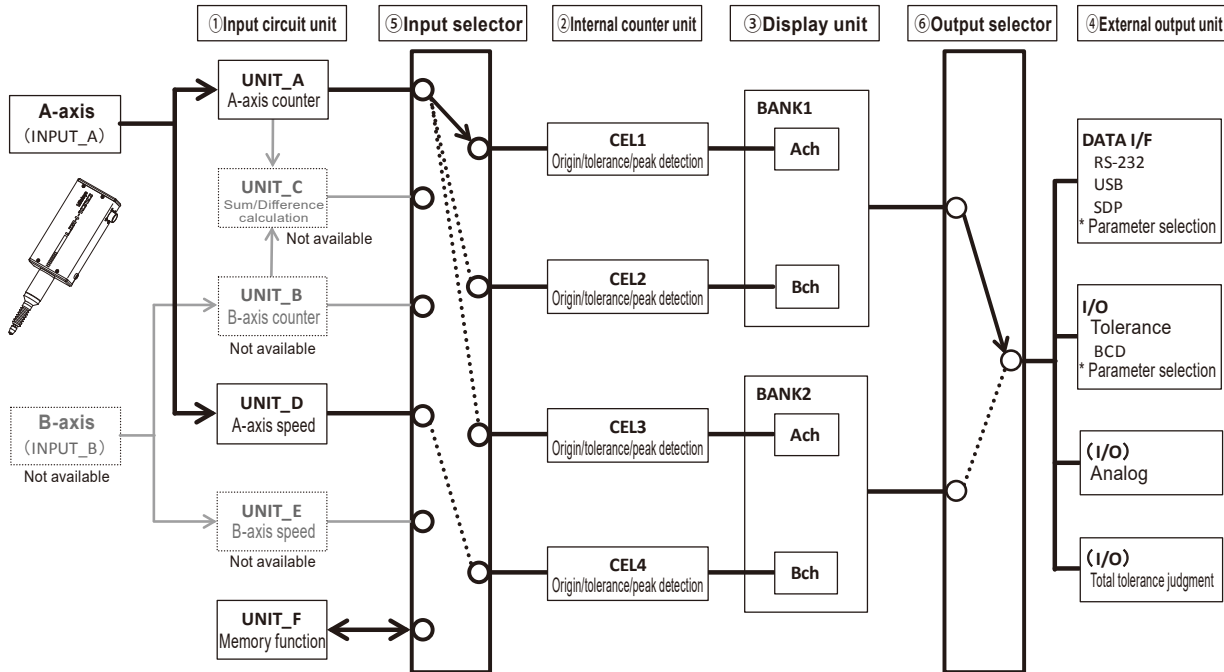

①Input circuit unit	UNIT_A–UNIT_F are provided for functions. <ul style="list-style-type: none"> • UNIT_A: Performs a counter measurement for A-axis. • UNIT_D: Performs a simple speed measurement for A-axis. • UNIT_F: Saves the displayed value.(Enabled even when the power switch is turned off) UNIT_B, UNIT_C, or UNIT_E cannot be used.
②Internal counter	Performs the origin setup, tolerance judgment, and peak detection operations on the input counter value.
③Display unit	There are two switchable display units, BANK1 and BANK2. <ul style="list-style-type: none"> • BANK1: Ach = CEL1 display/Bch = CEL2 display • BANK2: Ach = CEL3 display/Bch = CEL4 display As the factory default, Parameter Number 06 is set to "5" (optional one-axis display), disabling the display unit B and BANK switchover.Setting Parameter Number 06 to "6" (optional two-axis display) enables the display unit B, and setting it to "7" (optional four-axis display) enables BANK switchover as well.
④External output unit	You can use a parameter to select the output interface to use.
⑤Input selector	Connects UNIT to any CEL.
⑥Output selector	Outputs either the BANK_1 or BANK_2 display.

3 Parameter Setting

Connection between UNIT and CEL can be specified by the display mode selection of Parameter Number 06.

Tips

Among the input circuit units, UNIT_B, UNIT_C, or UNIT_E cannot be used for this product.

For details about the parameter setting, see  "3.1 Procedure for Setting Parameters" (page 17).

For details about the CEL-specific parameter setting, see  "3.3.3 CEL-Specific Parameters" (page 27).

For details about the display modes, see  "3.3.2 Details of Display Mode Selection (Parameter Number 06)" (page 24).

3.3.2 Details of Display Mode Selection (Parameter Number 06)

For this counter, Display mode can be selected by setting Parameter Number 06 as follows:

Set value	Display mode	BANK1		BANK2	
		CEL1	CEL2	CEL3	CEL4
0	Two-coordinate display	UNIT_A (A-axis counter)	UNIT_B (B-axis counter)	UNIT_A (A-axis counter)	UNIT_B (B-axis counter)
1	Calculation display	UNIT_C (A±B)	UNIT_A (A-axis counter)	UNIT_C (A±B)	UNIT_B (B-axis counter)
2	Dual display	UNIT_A (A-axis counter)	UNIT_A (A-axis counter)	UNIT_B (B-axis counter)	UNIT_B (B-axis counter)
3	Memory display	UNIT_A (A-axis counter)	UNIT_F (Memory)	UNIT_B (B-axis counter)	UNIT_F (Memory)
4	Speed display	UNIT_A (A-axis counter)	UNIT_D (A-axis speed)	UNIT_B (B-axis counter)	UNIT_E (B-axis speed)
5 (Default value)	Optional one-axis display	UNIT_A (A-axis counter)	-	-	-
6	Optional two-axis display	UNIT_A (A-axis counter) (Default value)	UNIT_B (B-axis counter) (Default value)	-	-
7	Optional four-axis display	UNIT_A (A-axis counter) (Default value)	UNIT_B (B-axis counter) (Default value)	UNIT_C (A±B) (Default value)	UNIT_A (A-axis counter) (Default value)

Tips

- The set values 0–4 of Parameter Number 06 do not allow the connection from UNIT to CEL to be modified.
- The set values 5–7 of Parameter Number 06 allow CEL to be connected to any UNIT.
- With the set value 0–4, CEL assigned to UNIT_B (B-axis counter), UNIT_C (A±B), or UNIT_E (B-axis speed) cannot be used, showing "Error40".

For details about the parameter setting, see  "3.1 Procedure for Setting Parameters" (page 17).

■ Display mode type

● Two-coordinate display (set value: 0)

A set of two counters (CEL) of BANK1 and 2 is used to display the two coordinates.

	BANK1		BANK2	
Ach (upper display)	CEL1	UNIT_A (A-axis counter)	CEL3	UNIT_A (A-axis counter)
Bch (lower display)	CEL2	Error 40 (UNIT_B (B-axis counter))	CEL4	Error 40 (UNIT_B (B-axis counter))

Tips

- CEL assigned to UNIT_B (B-axis counter) cannot be used, showing "Error40".
- The origin (preset) and tolerance can be set per BANK.

For details about BANK switchover, see  "4.2 Switching the Displayed BANK" (page 31).

For details about the origin setting (preset), see  "4.4 Preset" (page 32).

For details about the tolerance setting, see  "4.6 Tolerance Value Setting" (page 34).

3 Parameter Setting

● Calculation display (set value: 1)

The Sum/Difference calculation display cannot be used.

● Dual display of current value/peak value (set value: 2)

The current and peak values of one gage are simultaneously displayed.

	BANK1		BANK2	
Ach (upper display)	CEL1	UNIT_A (A-axis counter)	CEL3	Error 40 (UNIT_B (B-axis counter))
Bch (lower display)	CEL2	UNIT_A (A-axis counter)	CEL4	Error 40 (UNIT_B (B-axis counter))

Tips

- CEL assigned to UNIT_B (B-axis counter) cannot be used, showing "Error40".
- The origin sets of Ach (upper display) and Bch (lower display) are independent.

● Memory display (set value: 3)

The value of Ach (upper display) is saved in Bch (lower display). In addition to the most recently saved data, the maximum and minimum values from past data can also be read out. The saved data are not cleared even if the power switch is turned off.

	BANK1		BANK2	
Ach (upper display)	CEL1	UNIT_A (A-axis counter)	CEL3	Error 40 (UNIT_B (B-axis counter))
Bch (lower display)	CEL2	UNIT_F (Memory)	CEL4	UNIT_F (Memory)

Tips

- CEL assigned to UNIT_B (B-axis counter) cannot be used, showing "Error40".
- The memory unit is shared between BANK1 and BANK2. Used gages must have the same signal cycle output.
- The B_HOLD signal from the I/O connector can be used for external control.

For details about the procedures for saving, reading out, and clearing memory, see  "4.8 Registering, Reading, and Clearing Memory" (page 39).

For details about input/output from the I/O connector, see  "5.5 I/O Connector Terminal Function" (page 48).

● Speed display (set value: 4)

Displays the moving speed of the spindle simply. The display unit of speed is mm/s. In addition to the current speed, it displays the maximum speed when the maximum value (MAX) is selected in Peak mode.

	BANK1		BANK2	
Ach (upper display)	CEL1	UNIT_A (A-axis counter)	CEL3	Error 40 (UNIT_B (B-axis counter))
Bch (lower display)	CEL2	UNIT_D (A-axis speed)	CEL4	Error 40 (UNIT_E (B-axis speed))

Tips

- CEL assigned to UNIT_B (B-axis counter) or UNIT_E (B-axis speed) cannot be used, showing "Error40".
- The display of the last 1 to 3 digits may be fixed depending on the sampling cycle.
- The maximum speed in the reverse direction is displayed when the minimum value (MIN) is selected in Peak mode.
- The speed display is simplified and may not be correct.

● Optional one-axis display (set value 5), optional two-axis display (set value 6), optional four-axis display (set value 7)

Select the number of CELs to use from 1, 2, and 4, and connect each CEL to any UNIT. You can configure any measurement mode other than the set values 0–4 of Parameter Number 06. Set Parameter Number 06 to a value between 5–7, and connect UNIT according to the CEL-specific parameter.

Tips

UNIT_B (B-axis counter), UNIT_C (A±B), and UNIT_E (B-axis speed) cannot be used. If they are connected to CEL, they show "Error40".

For details about the CEL-specific parameters, see  "3.3.3 CEL-Specific Parameters" (page 27).

3.3.3 CEL-Specific Parameters

This section describes the parameters that can be set per CEL.

No.	Set value	Description/Set values (The values in bold indicate initial values.)
40	Individual CEL display selection	<p>Selects UNIT (counting method) to be displayed for each CEL when Parameter Number 06 is set to a value between 5–7. Modifying the value of Parameter Number 40 clears the preset and tolerance values.</p> <p>0: UNIT_A (A-axis counter) 1: (Not available) 2: (Not available) 3: UNIT_D (A-axis speed) 4: (Not available) 5: UNIT_F (Memory)</p>
41	Calculation with a constant	<p>Sets whether or not to multiply the internal counter value by one of the predetermined values or an arbitrary value. The internal counter value multiplied by the specified constant value is displayed as the measurement result.</p> <p>0: None 1: 1/2 times 2: 2 times 3: 10 times 4: Arbitrary value</p>
42	Lowest-order digit blank	<p>Hides the lowest-order digit. However, the lowest-order digit will be included in RS-232C output and in printouts.</p> <p>0: Display all digits 1: The lowest-order digit is blank</p>

Tips

- For this product, Parameter Number 40 cannot be set to 1, 2, or 4.
- When Parameter Number 41 is set to 4 (arbitrary value), accuracy guarantee is disabled.
- For details about the CEL-specific parameter setting, see  "4.7.1 Procedure for Setting CEL-Specific Parameters" (page 37).

3.4 Overview of Parameter Setting

This section gives an overview of parameter setting.

Tips

- The following figure does not illustrate the steps to set parameters.
- When setting parameters, each time you press [P.SET], the parameter number will advance from 00. When the number advances to the last number, it then returns to 00.
- If you select a set value 1 (CEL-specific parameter setting) for Parameter Number 00, you go to Parameter Number 40. When the number advances to 42, it then returns to 40.
- Be sure to set the parameters enclosed by a solid line. Set the parameters enclosed by a dashed line as necessary.

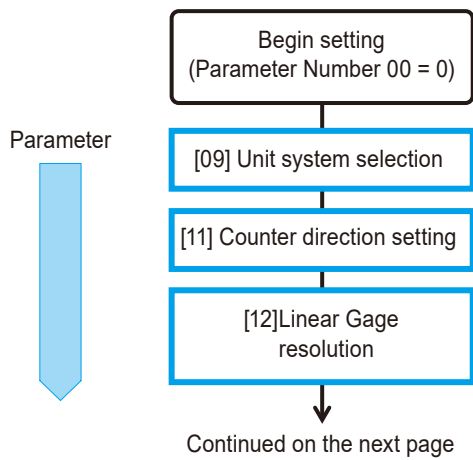

3 Parameter Setting

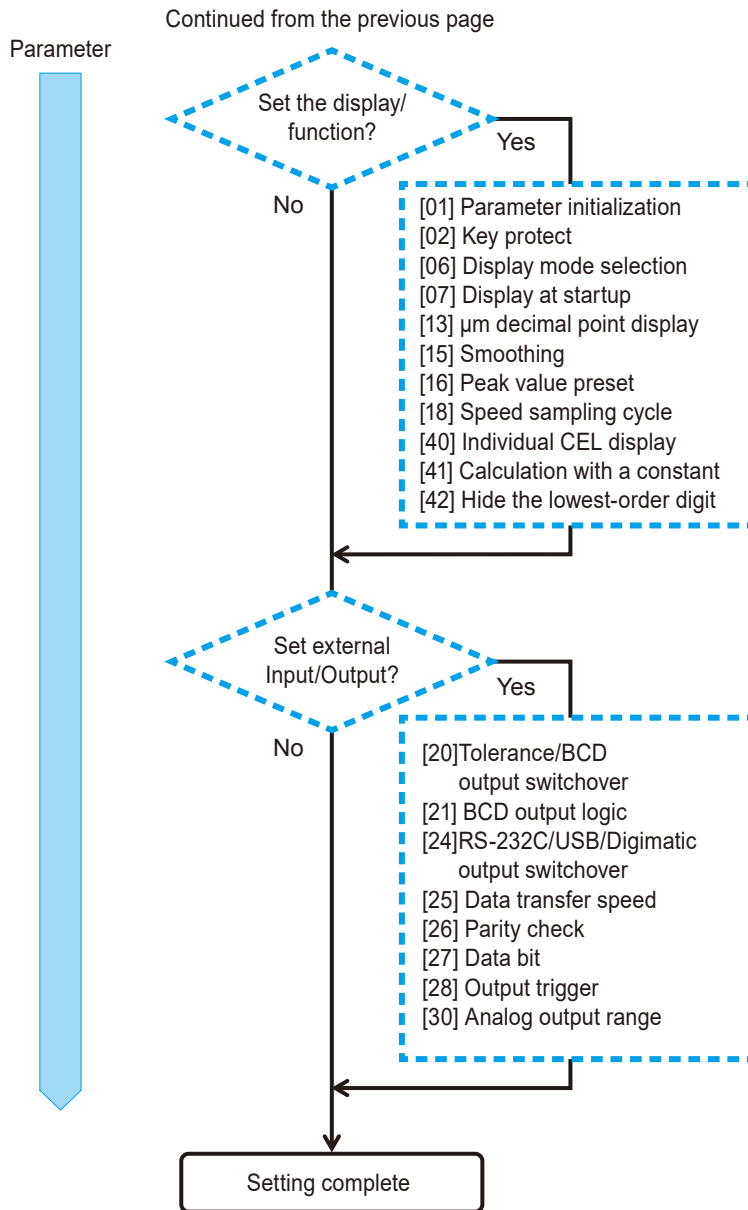

For details about the parameters, see ["3.2 List of Parameters"](#) (page 18).

For details about the CEL-specific parameters, see ["3.3.3 CEL-Specific Parameters"](#) (page 27).

MEMO



4 Basic Operations

4.1 Selection of Display A/B

For preset, peak measurement mode, and tolerance settings, specify Ach (upper display) or Bch (lower display).

1 Press [SEL].

» The selected channel (Ach (upper display) or Bch (lower display)) blinks.

Display example	Display contents
 <p>Channel number (CEL number) UNIT number</p>	<p>"CH01": Ach (upper display/CEL1) "A": UNIT_A connected</p>
 <p>Channel number (CEL number) UNIT number</p>	<p>"CH02": Bch (lower display/CEL2) "b": UNIT_B connected (LSD) "=": Setting of the calculation with a constant (out of accuracy guarantee)</p>

Tips

- The channel number used when switching the operation axis is the one used for RS-232 communication. For details, see  "5.4 RS LINK Function" (page 46).
- When the calculation with a constant is set, [=] is displayed in the LED of the least significant digit of Bch (lower display).
- When an error occurs, press [SEL] to restore the counter value status.

4.2 Switching the Displayed BANK

This counter can use the key or the input signal from the I/O connector to switch the internal counters CEL1–CEL4 per BANK.

1 Press and hold [P.SET], and then press [MODE].

» The displayed BANK will be switched.

Tips

- The BANK currently displayed appears in the BANK indicator.
- BANK cannot be switched when the display mode is set to the optional one- or two-axis display.
- For details on the measurement mode, see  "3.3.2 Details of Display Mode Selection (Parameter Number 06)" (page 24).

4.3 Zero Setting

Set Ach (upper display) and Bch (lower display) to zero when measuring.

- 1 Press [A_ZERO] or [B_ZERO].
 - » Pressing [A_ZERO] sets the counter value of Ach (upper display) to zero.
 - » Pressing [B_ZERO] sets the counter value of Bch (lower display) to zero.

Tips

Zero setting also clears the peak value and sets the maximum value (MAX), the minimum value (MIN), the current value, and the run-out width (TIR) to zero.

4.4 Preset

Replace the current value with an arbitrary value (Preset value).

Tips

The PA/PB signal input from the I/O connector can also be used for preset. When the I/O connector input/output is used, the Preset value set in advance is used for preset.

- 1 Press [SEL] to select one of the operation channels from Ach (upper display) and Bch (lower display).
- 2 Press [P.SET].

- » The decimal point blinks, and the previous Preset value appears.



- 3 Press [MODE].
 - » The input digit will shift to the right.

- 4 Press [A_ZERO] or [B_ZERO].
 - » The Preset value will be modified.



Tips

For the most significant digit, select the sign \pm also (0 \Rightarrow ... \Rightarrow 9 \Rightarrow -0 \Rightarrow ... \Rightarrow -9 \Rightarrow 0).

- 5 Repeat steps 3 and 4 until the desired Preset value is set.
- 6 Press [P.SET].
 - » The current value is replaced with the Preset value, and the counter display is restored.

Tips

To cancel the input, press [SEL]. The counter will return to the counter display.

4.5 Peak Mode Setting

In addition to the current value, the peak detection measurement can be made as the maximum value (MAX), the minimum value (MIN), and the run-out width (TIR).

Peak mode	Peak indicator	Display contents
Current value	MAX-TIR-MIN ○ ○	Current measured value of the gage head
Maximum value (MAX)	MAX-TIR-MIN ● ○	Maximum value after the peak value is cleared
Minimum value (MIN)	MAX-TIR-MIN ○ ●	Minimum value after the peak value is cleared
Run-out width (TIR)	MAX-TIR-MIN ● ●	Run-out width during the measurement (maximum value - minimum value)

Tips

The maximum response speed is different between the current value measurement and the peak measurement (MAX, MIN, and TIR).

For details, see  "7.1 Basic Specifications" (page 59).

4.5.1 Procedure for Switching Peak Mode

- 1 Press [SEL] to select one of the operation channels from Ach (upper display) and Bch (lower display).
- 2 Repeatedly press [MODE] until the desired indicator display is obtained.

4.5.2 Procedure for Clearing Peak Value

This section explains how to clear the peak value in Peak mode.

- 1 Press [SEL] to select one of the operation channels from Ach (upper display) and Bch (lower display).
- 2 Press [MODE] to select Peak mode.
- 3 Press [A_ZERO] or [B_ZERO].
 - » The peak value is cleared (MAX = MIN = current value, TIR = 0).

Tips

When the peak value is cleared for one CEL, it is also cleared for the other CELs if these CELs are all connected to the same UNIT.

4.6 Tolerance Value Setting

The Tolerance Judgment function supports the 3- and 5-step tolerance judgments.

Tips

- Set the set value of Parameter Number 20 to 0 (3-step tolerance) or 1 (5-step tolerance) in advance.
- When Parameter Number 20 is set to 2 (BCD output), the number of the tolerance steps remains unchanged as just before the BCD output is set.

4.6.1 3-Step Tolerance Value Setting (3-Step Tolerance Zone Selection)

With S1 and S4 set as the tolerance values, the 3-step tolerance judgment will be performed as follows:

	GO/NG indicator	I/O output
Measured value < S1	Amber indicator on	AL1 / BL1
$S1 \leq \text{Measured value} \leq S4$	Green indicator on	AL3 / BL3
$S4 < \text{Measured value}$	Red indicator on	AL5 / BL5

This section explains how to set the 3-step tolerance value.

- 1 Press [SEL] to select one of the operation channels from Ach (upper display) and Bch (lower display).
- 2 Press [LIMIT].
 - » The GO/NG indicator lights in amber. (Tolerance value S1 is selected.)
 - » The decimal point blinks, and the previous tolerance value appears.
- 3 Press [MODE].
 - » The input digit will shift to the right.
- 4 Press [A_ZERO] or [B_ZERO].
 - » The tolerance value will be modified.



Tips

For the most significant digit, select the sign \pm also (0 \Rightarrow ... \Rightarrow 9 \Rightarrow -0 \Rightarrow ... \Rightarrow -9 \Rightarrow 0).

- 5 Repeat steps 3 and 4 until the desired tolerance value is set.
- 6 Press [LIMIT].
 - » Tolerance value S1 will be applied.
 - » The GO/NG indicator lights in red. (Tolerance value S4 is selected.)
- 7 Set the tolerance value S4 using the same procedure as steps 3–5.

8 Press [LIMIT].

» The tolerance value S4 is determined, and the counter returns to the counter value status.

Tips

An error will occur unless $S1 \leq S4$. Press [SEL] to re-enter from S1.

4.6.2 5-Step Tolerance Value Setting (5-Step Tolerance Zone Selection)

With S1–S4 set as the tolerance values, the 5-step tolerance judgment will be performed as follows:

	GO/NG indicator	I/O output
Measured value < S1	Amber indicator on	AL1/BL1
$S1 \leq$ Measured value < S2	Amber indicator blinks	AL2/BL2
$S2 \leq$ Measured value \leq S3	Green indicator on	AL3/BL3
$S3 <$ Measured value \leq S4	Red indicator blinks	AL4/BL4
$S4 <$ Measured value	Red indicator on	AL5/BL5

This section explains how to set the 5-step tolerance value.

1 Press [SEL] to select one of the operation channels from Ach (upper display) and Bch (lower display).

2 Press [LIMIT].

» The GO/NG indicator lights in amber. (Tolerance value S1 is selected.)
 » The decimal point blinks, and the previous tolerance value appears.

Tips

Tolerance values are set in the order S1, S2, S3, S4. The GO/NG indicator displays as follows: (The tolerance value to be set is selected.)

Tolerance value	GO/NG indicator
S1	Amber indicator on
S2	Amber indicator blinks
S3	Red indicator blinks
S4	Red indicator on

3 Press [MODE].

» The input digit will shift to the right.

4 Press [A_ZERO] or [B_ZERO].

» The tolerance value will be modified.



Tips

For the most significant digit, select the sign \pm also ($0 \Rightarrow \dots \Rightarrow 9 \Rightarrow -0 \Rightarrow \dots \Rightarrow -9 \Rightarrow 0$).

4 Basic Operations

- 5 Repeat steps 3 and 4 until the desired tolerance value is set.
- 6 Press [LIMIT].
 - » Tolerance value S1 will be applied.
 - » The color of the OK/NG indicator changes to the one of the next tolerance value to be set.
- 7 Set the tolerance values S2, S3, and S4 with the similar operations in the steps 3–5.
- 8 Press [LIMIT].
 - » The tolerance value S4 is determined, and the counter returns to the counter value status.

Tips

An error occurs with the settings other than $S1 < S2 < S3 < S4$ or $S1 = S2 = S3 = S4$. Press [SEL] to re-enter from S1.

4.7 CEL-Specific Parameter Setting

4.7.1 Procedure for Setting CEL-Specific Parameters

1 Press and hold [P.SET], and then press [A_ZERO].

» The counter enters Parameter mode.

2 Press [A_ZERO] once to set Parameter Number 00 to 1 (CEL-specific parameter setting).

» The counter enters CEL-specific parameter mode.

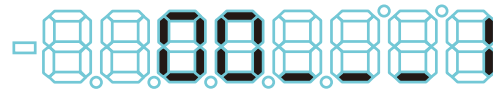

3 Press [P.SET] to display the parameter number to be modified.



4 Press [A_ZERO] to modify the set value of the parameter.



5 Press and hold [P.SET], and then press [A_ZERO].

» The counter returns to the counter value status.

4.7.2 Procedure for Setting Desired Multiplication Factor

When Parameter Number 41 is set to 4 (arbitrary value), specify a constant value.

Tips

An optional constant value can be set for each CEL.

1 Press and hold [P.SET], and then press [A_ZERO].

» The counter enters Parameter mode.

2 Press [A_ZERO] twice to set Parameter Number 00 to 2 (optional constant setting).

» The counter enters optional constant setting mode.



4 Basic Operations

3 Press [P.SET].

- » The previous set value and the CEL number appear in the upper and lower sections respectively.

Display A



Display B



4 Press [MODE].

- » The input digit will shift to the right.

5 Press [A_ZERO].

- » The value changes (available range: ± 9.99999).

Display A



Display B



6 Press and hold [P.SET], and then press [A_ZERO].

- » The CEL number changes.

Display A



Display B



7 Set CEL2, CEL3, and CEL4 using the same procedure as steps 4 and 5.

8 Press and hold [P.SET], and then press [A_ZERO].

- » The counter returns to the counter value status.

4.8 Registering, Reading, and Clearing Memory

This section describes the procedure to register, read, and clear the memory.

Tips

This operation is available when the set value of Parameter Number 06 is 3 (memory).

● Procedure for registering memory

1 Press [B_ZERO].

» The current value of Ach (upper display) is saved in Bch (lower display).

● Procedure for reading saved data

1 Press [SEL] to select Bch (lower display).

2 Press [MODE] (switch to Peak setting mode).

» Each time you press [MODE], the displayed memory value cycles through the maximum value → minimum value → run-out width.

● Procedure for clearing memory

1 Press [SEL] to select Bch (lower display).

2 Press [P.SET].

» The values in the memory (maximum value/minimum value/run-out width) are cleared, and then the current value in Ach (upper display) is displayed.

MEMO

5 External Input/Output Function

This product is equipped with the following interfaces that enable the connection of external equipment.

Interface	Parameter setting (No. 24)	Connectable equipment	Functions
Digimatic output	2	Digimatic Mini-Processor (DP-1VA LOGGER)	<ul style="list-style-type: none"> Printing the measurement data, statistical calculation results, etc.
USB	1	PC (for SENSORPAK)	<ul style="list-style-type: none"> Data output to a PC
RS-232C	0	PC, PLC	<ul style="list-style-type: none"> Data output to a PC, PLC Control from external system
I/O connector	-	Equipment such as a switch or control unit	<ul style="list-style-type: none"> Data output to PLC External control of the counter

Tips

PLC: programmable logic controller

5.1 Digimatic Output Function (for DP-1VA LOGGER)

You can print the measurement data by connecting to the Digimatic Mini-Processor (DP-1VA LOGGER), which is sold separately. To do this, connect the Digimatic cable to the RS_LINK connector (OUT) of the counter.

Tips

- A maximum of 6 digits can be printed. When the counter displays the value in 7 or 8 digits, the last 6 digits will be printed. For example, when "12.34567 mm", which has 7 digits, is output, it will be printed as "2.34567 mm".
- Set the DP-1VA LOGGER to compatible mode.
For details on the setting method and operations, see  "DP-1VA LOGGER Digimatic Mini-Processor User's Manual".
- When an error occurs, an asterisk is printed.
- If you use an old model instead of the Digimatic Mini-Processor DP-1VA LOGGER, contact your dealer or the nearest Mitutoyo sales office.

5.2 USB Communication Function

By installing SENSORPAK (Mitutoyo product) on a PC, you can load measurement data from the counter to the PC by connecting the counter to the PC with a USB connecting cable (A-B type). A USB connecting cable is not supplied. You must provide one.

Tips

- The USB port for communication with SENSORPAK.
- SENSORPAK supports communication via USB 2.0 or later.
- For details on the SENSORPAK, see "SENSORPAK User's Manual".

5.3 RS-232C Communication Function

By connecting to a PC or PLC via RS-232C, you can load measurement data and manipulate various settings of the counter through remote operation.

You can also save and load parameters.

5.3.1 Connections

Compatible plug and pin assignment

Compatible plug: D-sub 9-pin (socket contact), inch screw type

Cable: A commercial RS-232C cross-type cable

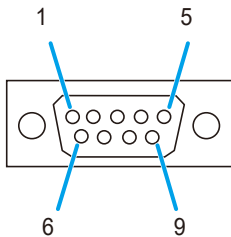

Pin number	Signal name	I/O
2	RXD	IN
3	TXD	OUT
4	DTR	OUT
5	GND	–
6	DSR	IN
7	RTS	OUT
8	CTS	IN
1, 9	NC	–

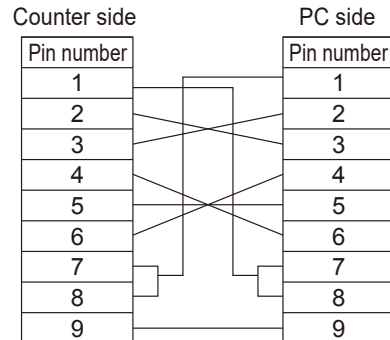

Communication specification (conforming to EIA RS-232C)

Item	Description
Home position	DTE (Data Terminal Equipment), use a cross-type cable.
Communication method	Half-duplex, non-procedural mode
Data transfer speed	4800 bps/9600 bps/19200 bps
Bit configuration	Start bit: 1 Data bits: 7 bits/8 bits (ASCII code, upper-case characters) Parity: None/Even parity/Odd parity Stop bit: 2

Tips

- Set the communication conditions using parameters.
For details, see "3.2 List of Parameters" (page 18).
- Use commercial terminal software for communication with a PC.

5.3.2 Communication Commands

This section explains the command format from a PC or PLC, output from the counter, and operation details.

Command format	Corresponding output	Operation details	Notes
GA**CRLF	G#**, +01234.567CRLF	Outputs "Display value"	See *1
CN**CRLF	CH**CRLF	Switches the display to "Current value"	See *2
CX**CRLF	CH**CRLF	Switches the display to "Maximum value"	See *2
CM**CRLF	CH**CRLF	Switches the display to "Minimum value"	See *2
CW**CRLF	CH**CRLF	Switches the display to "TIR"	See *2
CR**CRLF	CH**CRLF	Zero setting	
CL**CRLF	CH**CRLF	Clears the peak value	
CP**,+01234567CRLF	CH**CRLF	Inputs the preset value	See *3
CD**,+01234567CRLF	CH**CRLF	Inputs tolerance value S1	See *4
CE**,+01234567CRLF	CH**CRLF	Inputs tolerance value S2	See *4
CF**,+01234567CRLF	CH**CRLF	Inputs tolerance value S3	See *4
CG**,+01234567CRLF	CH**CRLF	Inputs tolerance value S4	See *4
CS**CRLF	CH**CRLF	Clear error	
CK**CRLF	CH**,%CRLF	Checks the HOLD status	See *5

1 "" denotes an RS-232C Linear Gage channel number (01 to 99) ("00" means all channels). Channels 01 to 04 correspond to CEL1 to CEL4, respectively.

A "#" after "G" in the output data denotes the type of data (N: Current value, X: Maximum value, M: Minimum value, W: TIR).

*2 If Peak mode is switched using an RS command, data will not be backed up in the internal memory.

*3 For the preset value and tolerance value, enter a value consisting of a +/- sign and an 8-digit of numeric value without a decimal point.

*4 Perform the tolerance setting in the order CD command→CG command for 3-step tolerance, and in the order CD command→CE command→CF command→CG command for 5-step tolerance.

An error will be output in the following cases. In this case, redo the settings from the CD command.

- If the order of the tolerance values is incorrect
- If the step count and sent data are different
- If incorrect data is sent

*5 The response output from the CK command ("%") shows the HOLD status.

%=0: Normal status/1: HOLD status

If Parameter Number 28 is set to 1 (channel synchronization), all counters connected via RS LINK will switch to the HOLD state when a CK command is sent.

The HOLD state will be canceled by reading out data with the GA command.

The CK command is valid only with channel number 1 (CK01CRLF).

Tips

- CRLF means CR (carriage return) plus LF (line feed).
- The output when an error occurs is "CH**,Error\$\$CRLF". \$\$ is the error code. For details, see  "6.2.1 List of Error Codes" (page 56).
- After you have received a response output corresponding to the command, send the next command. If there is no response from your command, clear the communication buffer, wait 1 second or more, and then send the command again.
- The RS Communication function will be suspended during key operations (e.g., setting parameters, the pre-set value, or tolerance values). Command and data output operations will resume when the counter returns to a state where counting is possible.
- To cancel the stand-by state, use "CS00CRLF" (all channels specified).
- You can perform the communication test to check a specific operation by sending an RS-232C command from the keyboard to the counter using the Hyperterminal (software installed with Windows by default).

5.3.3 Saving and Loading Parameters

You can output the set parameter data from the counter to a PC and save it to a text file. You can also load the parameter data saved in a PC to the counter.

This section explains how to save parameters.

Tips

To communicate with a PC, you must have appropriate communication software on the PC. Use commercial terminal software.

■ Saving parameters

- 1** Press and hold [P.SET], and then press [A_ZERO].
 - » The counter enters Parameter mode.
- 2** Press [A_ZERO] three times to set the Parameter Number 00 to 3.
- 3** Press [P.SET].

- » The display to the right appears for 1 second, and then the data is output to the PC.
- » After the data is transmitted, the counter returns to the stand-by state.



Tips

- Transmission conditions (fixed): 9600 bps, 7-bit data, even parity, 2-bit stop bits
- Connect the counter to a PC one-to-one (LINK connection not permitted).

● Example of external output of parameters

An example of the output of parameters is shown below.

Tips

The set values for the parameters in the table below are set by the user.

<<Output example>>

```
CQ01,**EH-S [200]**:00
CQ01,P02___=[0],0-1:02
CQ01,P05___=[0],0-1:03
...
CQ01,P10_A_=[1],0-3:36
CQ01,P10_B_=[1],0-3:37
...
CQ01,P40_1_=[0],0-5:42
CQ01,P40_2_=[1],0-5:43
CQ01,P40_3_=[2],0-5:44
CQ01,P40_4_=[0],0-5:45
...
CQ01,*parameter END*:FF
```

<<Data syntax>>

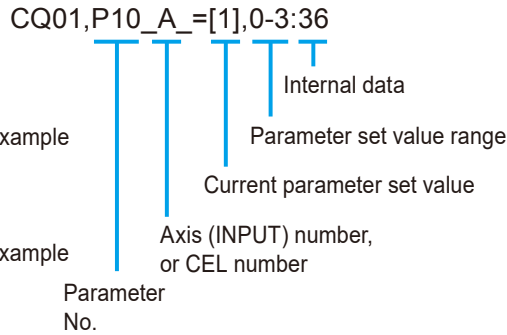

■ Loading parameters

This section explains how to load parameters.

Tips

- When loading parameters, you cannot extract only one parameter to change it. Be sure to describe all parameters in one file and load them.
- If parameters are set incorrectly, the count value will not be displayed correctly. For details about the parameters, see "3.3 Details of Display Mode" (page 22).

1 Press and hold [P.SET], and then press [A_ZERO].

» The counter enters Parameter mode.

2 Press [A_ZERO] four times to set the Parameter Number 00 to 4.

3 Press [P.SET].

» The display appears as to the right.



4 Send the parameter file from the PC.

» If it is successfully received, the display to the right will appear.



5 Press [P.SET].

» The counter returns to the counter value status.

Tips

After loading the parameters, turn off the power switch once, and then turn it on again.

5.3.4 Timing Chart

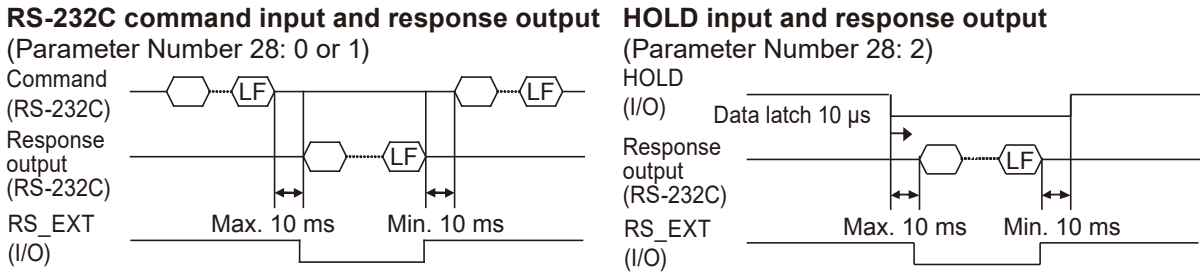

Tips

- RS output will be suspended during command operation.
- While the HOLD trigger is selected, the RS-232C commands are disabled.
- When connected via RS LINK, RS_EXT of the last counter is active.

5.4 RS LINK Function

With PC (including SENSORPAK) or PLC control, you can control a maximum of 10 counters using the RS LINK function.

5.4.1 Connections

Connect between IN and OUT of the RS_LINK connectors as shown in the following figure.

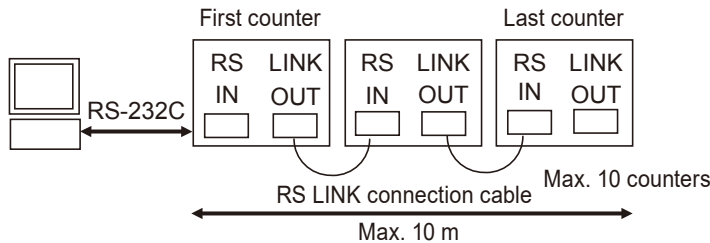

Tips

- Do not connect anything to the RS_LINK connector (IN) of the first counter or to the RS_LINK connector (OUT) of the last counter.
- When the power switch is turned on and the settings are initialized, the channel numbers of the Linear Gage will automatically be assigned 01, 02, 03, and so on, from the first counter in the order in which they are connected.
- Contact Mitutoyo if you wish you connect 10 or more counters or use a total cable length of 10 m or more.
- For about the RS LINK connection cable, see [7.3 Option] (page 62).

■ Precautions for startup

- Either turn on the power switches of all the counters simultaneously or turn on the power switch of each counter sequentially, beginning with the first one.
- After startup, [- - - -] will blink, and then, after the initial settings have completed, the counter en-

5 External Input/Output Function

ters the stand-by state, where [- - - -] is displayed. The RS LINK Function can be canceled using [SEL], an external HOLD signal, or an RS command.

Tips

For details, see "6.2.1 List of Error Codes" (page 56).

- Parameters relating to RS-232C (No. 25 to 28) can be modified only on the first counter. If you modify a parameter, reset the power switch of all the connected counters.

5.4.2 Assignment of CHs

When the power is turned on, the states of the counters are determined, and the CHs (channels) used by RS-232C commands are automatically assigned.

The CHs are assigned starting from 01, from the CELs of the first counter.

For counters with the display mode set to the optional one- or two-axis display, CHs are assigned to only the used CELs and not to unused CELs.

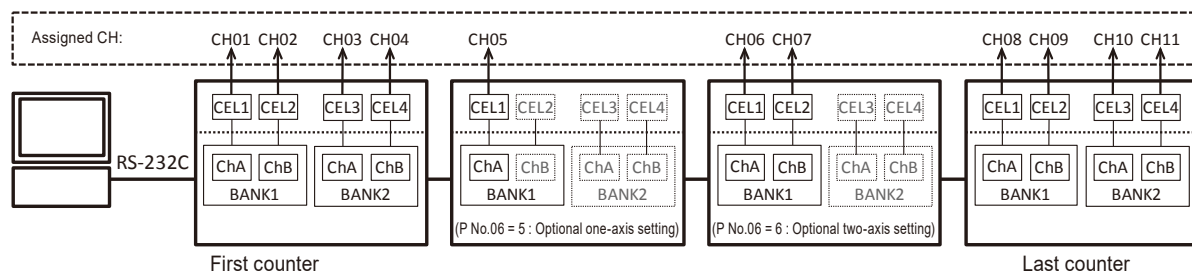

For details about the display modes, see "3.3 Details of Display Mode" (page 22).

5.4.3 RS-232C Data Output Duration

The maximum output duration of the command to output all data (GA00CRLF) can be calculated with the formulas below.

- When the transmission rate is 9600 bps

Maximum output duration [ms] = Number of connected counters × 5 + Number of connection channels × 17 + 6

Calculation example

One EH-102 + 1 channel connection = 1 × 5 + 1 × 17 + 6 = Max. 28 ms

Ten EH-102 + 20 channels connection = 10 × 5 + 20 × 17 + 6 = Max. 396 ms

- When the transmission rate is 19200 bps

Maximum output duration [ms] = Number of connected counters × 5 + Number of connection channels × 8.5 + 3

Calculation example

One EH-102 + 1 channel connection = 1 × 5 + 1 × 8.5 + 3 = Max. 16.5 ms

Ten EH-102 + 20 channels connection = 10 × 5 + 20 × 8.5 + 3 = Max. 223 ms

Tips

Processing time of the PC is not included.

5.5 I/O Connector Terminal Function

Through the I/O connector, the signal of tolerance judgment results, measurement data, etc. can be output to an external device. You can also switch the displayed BANK, switch Peak mode, activate the Preset function, clear the peak value, etc., by an external signal input.

5.5.1 Connections

Compatible plug and pin assignment

Compatible plug:

- Option No. 02ADB440 (plug and cover set)
- Commercial plug 10136-3000PE (3M), cover 10336-52A0-008 (3M)
- Commercial plug DX40M-36P (HIROSE), cover DX30M-36-CV (HIROSE)

Cable: Use shielded wires and limit the connecting cable length to 3 m or less.

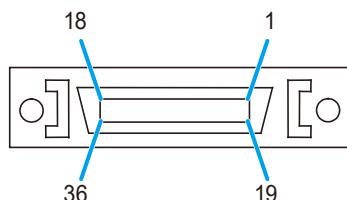

Pin number	I/O	Tolerance judgment output mode		BCD output mode	
		Name	Functions	Name	Functions
1, 2	-	COM	Internally connected to GND	COM	Internally connected to GND
3	O	AL1	Ach (upper display) tolerance judgment result output • Relevant terminal output: "L" • Output on error: AL1, AL5: "L"	A_bit0	Ach (upper display) data
4	O	AL2		A_bit1	
5	O	AL3		A_bit2	
6	O	AL4		A_bit3	
7	O	AL5		A_SIGN	
8	I/O	ALLGO	Total tolerance judgment result output GO (OK): "H" NG: "L"	READY	Data valid: "L"
9	O	RS_EXT	RS output in process: "L"		
10	O	NOMAL	Output when counting is possible: "L", Output on error: "H"		
11	O	BL1	Bch (lower display) tolerance judgment result output • Relevant terminal output: "L" • Output on error: BL1, BL5: "L"	B_bit0	Bch (lower display) data
12	O	BL2		B_bit1	
13	O	BL3		B_bit2	
14	O	BL4		B_bit3	
15	O	BL5		B_SIGN	
16 to 21	-	-	Not connected		
22	O	A_ANG	Ach (upper display) analog output		
23	O	B_ANG	Bch (lower display) analog output		
24	-	AGND	GND for analog		
25	I	SET1	During DISP, MODE, PA, or PB input: Function setup. During input, the decimal point will blink.		
26	I	SET2			
27	I	SET3			

5 External Input/Output Function

Pin number	I/O	Tolerance judgment output mode		BCD output mode	
		Name	Functions	Name	Functions
28	I	DISP	Displayed BANK specification: In combination with SET. During input, the decimal point will blink.		
29	I	MODE	Peak switchover: In combination with SET. During input, the decimal point will blink.		
30	I	BCDCK	BCD output specification: In combination with SET. During input, the decimal point will blink.		
31	I	EXTTRG	USB trigger		
32	I	A_HOLD	Ach (upper display) display: HOLD During input, the decimal point will blink.		
33	I	B_HOLD	Bch (lower display) display: HOLD During input, the decimal point will blink.		
34	I	HOLD	HOLD/Error cancel input During input, the UNIT indicator will blink.		
35	I	PA	Ach (upper display) Preset/Peak clear (in Peak, HOLD mode) During input, the decimal point will blink.		
36	I	PB	Bch (lower display) Preset/Peak clear (in Peak, HOLD mode) During input, the decimal point will blink.		

Tips

- For external input, negative logic (L = enabled) is used.
- "I/O" refers to the first letters of "Input/Output" respectively. Refer to the input circuit for "I", and the output circuit for "O".

Input/Output circuit

Output circuit

Transistor is on when the output is "L" (open collector).

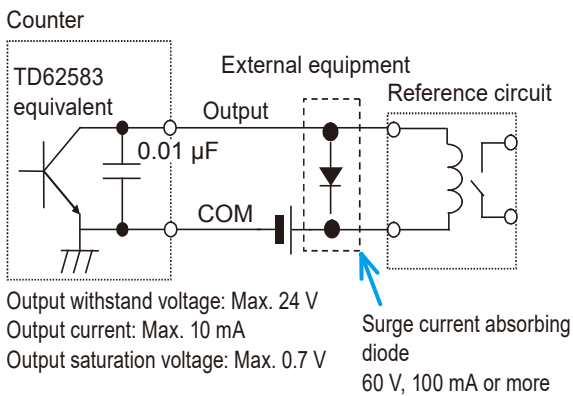

Input circuit

Input is valid when the input voltage is "L".

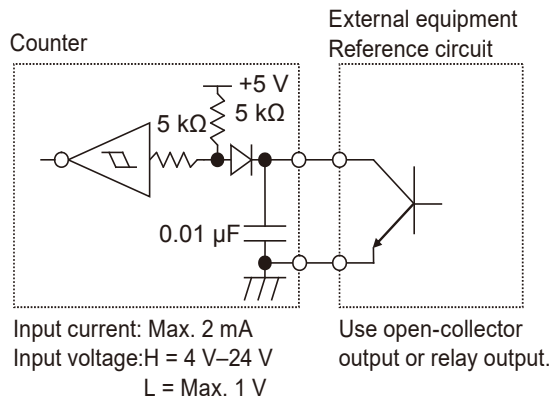

NOTICE

When using relays, incorporate a surge-current-absorbing diode or a protective circuit. If no protection is incorporated, the IC in the counter may be damaged.

5.5.2 Output Function

Output of total tolerance judgment result

The AND of the tolerance judgment results of all CELs is output. When multiple counters are connected, the total judgment can be output.

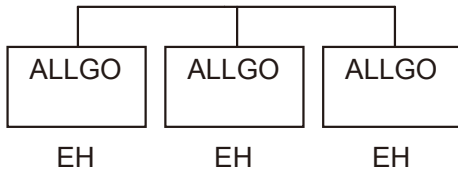

Judgment	Total judgment indicator	External output ALL_GO
All counters OK	Green	H
All or some counters NG	Amber	L
Error	Red	L

Tips

- To enable this function, select 0 or 1 as the set value of Parameter Number 20.
- For the Total Judgment across multiple counters, wire the number 8 pins (ALLGO: total tolerance judgment result output) together.
- For USB output, the total judgment indicator lights in amber under normal conditions and in red when an error has occurred. Perform the total tolerance judgment with SENSORPAK (optional software).
- For BCD output, the total judgment indicator lights in green under normal conditions and in red when an error has occurred.
- For details on the timing chart, see "5.5.4 Timing Chart" (page 52).

BCD output

Outputs measurement data in BCD format. Measurement data from Ach (upper display) and Bch (lower display) is output simultaneously in 4-bit units beginning with the least significant digit.

The following shows the data format when the Parameter Number 21 is set to "0".

	LSD (Least significant digit)				MSD (Most significant digit)			
	D1	D2	D3	D4	D5	D6	D7	D8
A bit0/B bit0	1×10 ⁰	1×10 ¹	1×10 ²	1×10 ³	1×10 ⁴	1×10 ⁵	1×10 ⁶	1×10 ⁷
A bit1/B bit1	2×10 ⁰	2×10 ¹	2×10 ²	2×10 ³	2×10 ⁴	2×10 ⁵	2×10 ⁶	2×10 ⁷
A bit2/B bit2	4×10 ⁰	4×10 ¹	4×10 ²	4×10 ³	4×10 ⁴	4×10 ⁵	4×10 ⁶	4×10 ⁷
A bit3/B bit3	8×10 ⁰	8×10 ¹	8×10 ²	8×10 ³	8×10 ⁴	8×10 ⁵	8×10 ⁶	8×10 ⁷
A SIGN/B SIGN	Sign	BANK	PEAK1	PEAK2	(Not used)	(Not used)	(Not used)	(Not used)

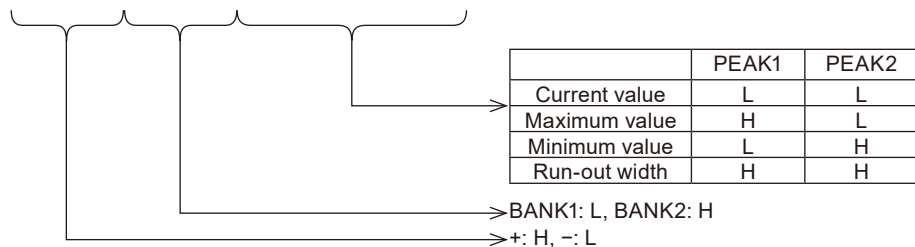

Tips

- When the Parameter Number 21 is set to "1", the output data logic is inverted.
- For details about the parameters, see "3.2 List of Parameters" (page 18).

5 External Input/Output Function

Example of output data (when the Parameter Number 21 is set to "0")

	D1	D2	D3	D4	D5	D6	D7	D8
A bit0	H	L	L	H	L	H	L	H
A bit1	L	L	H	L	L	H	H	L
A bit2	L	L	H	H	H	L	L	L
A bit3	L	L	L	L	L	L	L	L
A SIGN	H	H	L	L	(Not used)	(Not used)	(Not used)	(Not used)

↓

+12345601/BANK2 Ach/Current value

Tips

- To enable this function, select set value 2 (BCD output) of Parameter Number 20 (Tolerance/BCD output mode switching).
- It is possible to invert the data output logic by setting Parameter Number 21 (logic selection) to 1 (H).
- For details on the timing chart, see "5.5.4 Timing Chart" (page 52).

■ Analog output

Movement of the spindle of the gage head can be monitored as linear voltage by measuring the voltage between terminals with a pen recorder or oscilloscope.

Ach (upper display): Pin numbers 22–24

Bch (lower display): Pin numbers 23–24

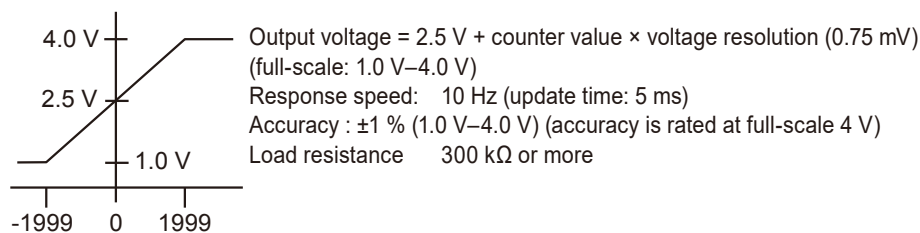

Parameter No. 30	Measurement range [mm] (range resolution [mm])			
	10 μm resolution setting	1 μm resolution setting	0.1 μm resolution setting	0.01 μm resolution setting
0	±19.99 (0.01)	±1.999 (0.001)	±0.1999 (0.0001)	±0.01999 (0.00001)
1	±199.90 (0.1)	±19.990 (0.01)	±1.9990 (0.001)	±0.19990 (0.0001)
2	±1999.00 (1)	±199.900 (0.1)	±19.9900 (0.01)	±1.99900 (0.001)

5.5.3 Input Function

With an external signal input, you can switch the BANK, switch Peak mode, activate the Preset function, clear the peak value, set the memory, and clear the memory. You can also activate a HOLD on the counter values of Ach (upper display) and Bch (lower display) either separately or simultaneously.

Tips

For details on the timing chart, see "5.5.4 Timing Chart" (page 52).

5.5.4 Timing Chart

■ Tolerance judgment result output

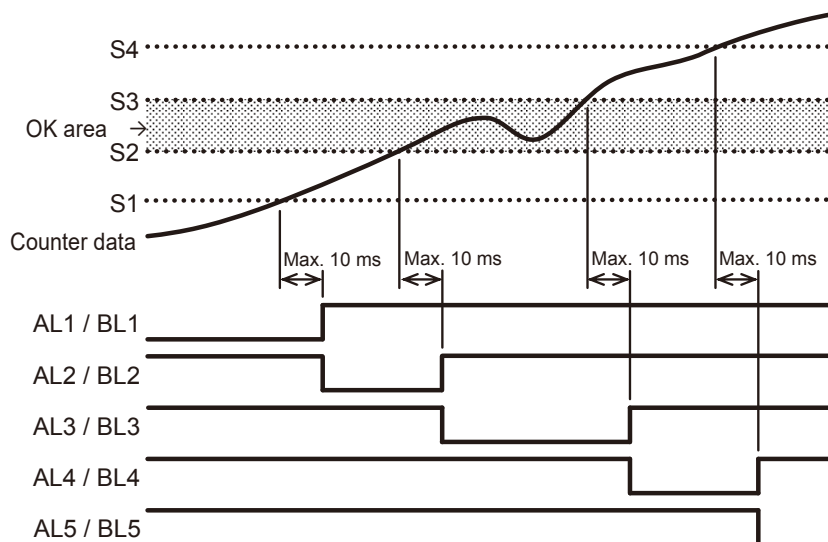

Tips

After acquiring the counter data, there is a maximum 10 ms delay before the tolerance judgment result is output.

■ BCD output

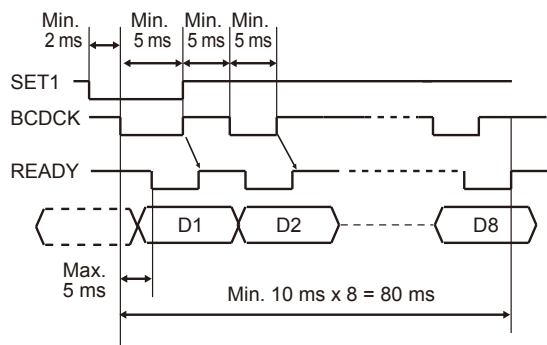

Tips

- "SET1" and "BCDCK" (BCD clock) denote input signals, and "READY" denotes the output signal.
- The BCD data (D1, D2 in the figure above) will be modified at the fall of the BCD clock while SET1 is input. When the BCD data is accepted, the READY signal falls. The time to accept the data after the fall of the BCD clock is 5 ms maximum. The READY signal rises together with the BCD clock.
- If SET1 is turned to L during data output, the data output is stopped, and then a new data output starts from D1.

External signal input

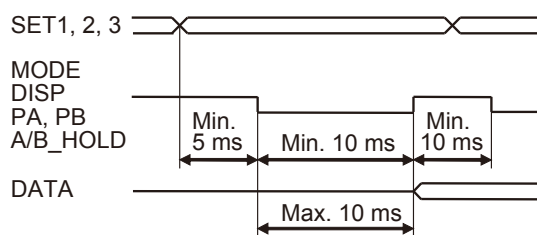

Refer to the following table to set the SET signal.

After setting, leave a gap of 5 ms or more, and then input the input signal of the function to change for at least 10 ms.

The data will be modified within 10 ms after the fall of the input is confirmed.

DISP (pin number 28):

Switching the displayed BANK

	SET3	SET2	SET1
BANK1	H	H	H
BANK2	H	H	L

PA/PB (pin numbers 35, 36):

Preset, Peak clear

	SET3	SET2	SET1
Preset	H	H	H
Peak clear	H	H	L

MODE (pin number 29):

Switching Peak

	SET3	SET2	SET1
NOMAL	H/L	H	H
MAX	H/L	H	L
MIN	H/L	L	H
TIR	H/L	L	L

A/B_HOLD (pin numbers 32, 33):

Setting/clearing memory

	SET3	SET2	SET1
Setting memory	H	H	H
Clearing memory	H	H	L

Tips

- During Peak mode, the peak value will be cleared when you input the PA/PB signal while HOLD is being input.
- When switching Peak mode, SET3 is H for Ach (upper display) and L for Bch (lower display).
- A/B_HOLD signal is available when the relevant channel is UNIT F (memory unit).

■ Power on/error cancellation

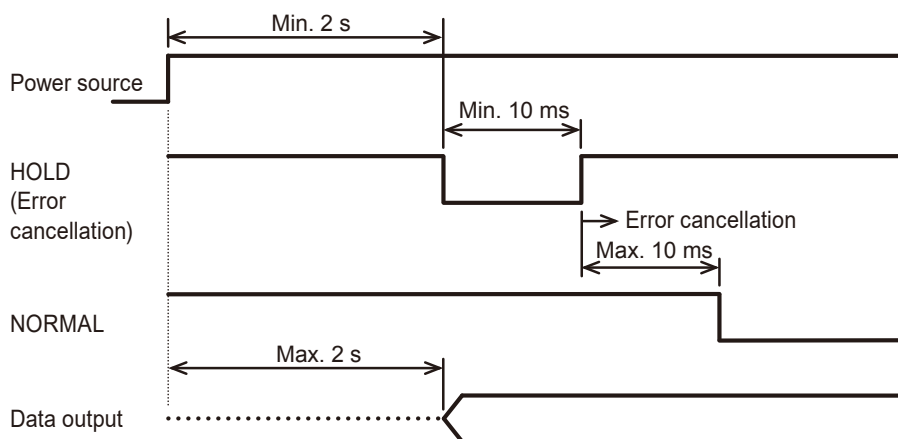

Tips

When the power is turned on, NORMAL is H (error state). Cancel the error state before use.

■ Data HOLD

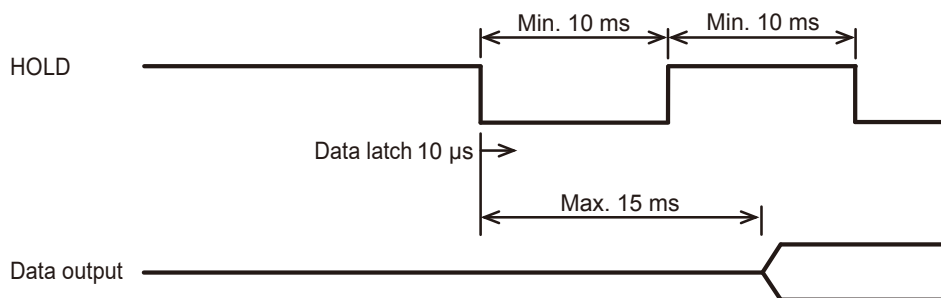

Tips

During the peak detection, the peak value will be cleared when PA/PB is input while HOLD is being input.

■ Display HOLD

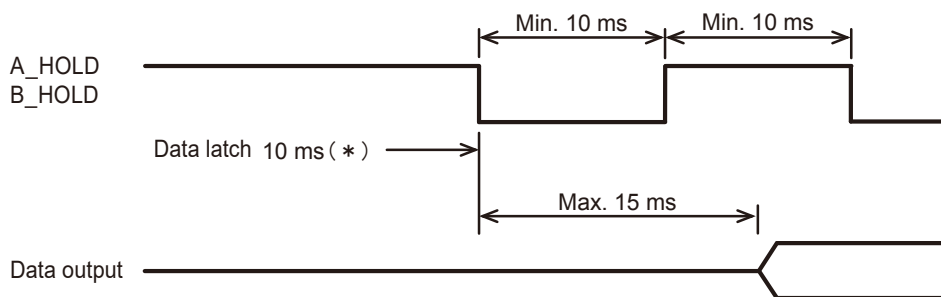





Tips

A delay of approximately 10 ms occurs between the internal counter data and the displayed data.

6 Troubleshooting

6.1 Troubleshooting

When the counter does not operate as expected, refer to the causes and solutions for trouble listed below.

Problem	Cause	Solution
The counter value is incorrect (not counting).	Peak mode (MAX or MIN is lit) is active.	Cancel Peak mode. For details, see  "4.5.1 Procedure for Switching Peak Mode" (page 33).
	The HOLD signal (UNIT is blinking) is being input.	Check the external input.
	Calculation with a constant function is set.	Cancel the calculation with a constant function. (Set Parameter Number 41 to 0.)
	The gage output signal pitch is changed.	Set Parameter Number 10 to an appropriate value. For details, see  "3.2 List of Parameters" (page 18).
Cannot execute Zero setting.	Peak mode is active.	Cancel Peak mode. For details, see  "4.5.1 Procedure for Switching Peak Mode" (page 33).
Cannot establish RS-232C communication.	The RS-232C connecting cable is not properly connected.	Check the cable connection.
	RS-232C mode is not active.	Activate RS-232C mode. (Set Parameter Number 24 to 0.)
	The command or HOLD trigger setting is not appropriate.	Check the command or HOLD trigger setting (Parameter Number 28).
	The communication conditions are not set correctly.	Check the settings of the communication conditions. For details, see  "3.2 List of Parameters" (page 18).

6.2 Error Messages

6.2.1 List of Error Codes

Display/ total tolerance indicator	RS-232C output	NOM signal	Tolerance/ BCD	Cause	Solution/ Error cancellation method
Error 10 Red indicator on	Error_10	H	L1 = L L5 = L FFFF10	Abnormal power voltage	Connect to the specified voltage. Automatic cancellation
[----] blinks -	-	H	L1 = H L5 = H -	RS link is in its initial setting state	Re-check the RS LINK connection cable connection. Automatic cancellation, or turn on the power switch again.
[-----] Red indicator on	Error_15	H	L1 = L L5 = L FFFF15	In stand-by state after power-on or a power interruption	Re-check the power if a power interruption has occurred. • [SEL] • CS00CRLF (RS) • HOLD input (I/O)
Error 20 Red indicator on	Error_20	H	L1 = L L5 = L FFFF20	Overspeed	Revise the measurement condi- tions. • [SEL] • CS00CRLF (RS) • HOLD input (I/O)
Error 30 Red indicator on	Error_30	H	L1 = L L5 = L FFFF30	Counter value is 8 digits or more	Modify the preset value. • [SEL] • CS00CRLF (RS) • HOLD input (I/O)
Error 40 Red indicator on	Error_40	H	L1 = L L5 = L FFFF40	Gage head mal- function, over- speed, or use of UNIT_B, UNIT_C, or UNIT_E	• Check that the gage head is connected properly. • Revise the measurement condi- tions. • Check the connection between CEL and UNIT. • [SEL] • CS00CRLF (RS) • HOLD input (I/O)
Counter value -	Error_50	L	Counter value status Counter value status	RS communication setting malfunction	Set the RS communication condi- tions again. Automatic cancellation

Display/ total tolerance indicator	RS-232C output	NOM signal	Tolerance/ BCD	Cause	Solution/ Error cancellation method
Counter value -	Error_52	L	Counter value status Counter value status	RS command mal- function	Revise the RS command. Automatic cancellation
Error 55 Red indicator on	-	H	L1 = L L5 = L FFFF55	RS LINK malfunc- tion HOLD signal mal- function	Check the unit's connection status, I/O connector peripheral circuit, power, etc. Turn on the power switch again.
Error 80 Red indicator on	Error_80	H	L1 = L L5 = L FFFF80	Peak detection error (Overspeed)	Revise the measurement condi- tions. • [SEL] • CS00CRLF (RS) • HOLD input (I/O)
Error 90 -	Error_90	L	Counter value status Counter value status	Tolerance value setting error or parameter setting error	• Input the tolerance value again. • Input the parameter value again. [SEL]
Error 95 -	Normal output	L	Counter value status Counter value status	Key protect	Cancel the key protection param- eters. Automatic cancellation

Tips

- In the "Solution/Error cancellation method" column, "RS" denotes an RS-232C command and "I/O" denotes an external HOLD signal.
- The error output format of RS-232C is "CH**,Error\$\$CRLF".
- "Error 40" (gage head malfunction) is also displayed when no gage head is connected.
- "Error 90" and "Error 95" are displayed when a tolerance value setting error occurs due to a key operation.
- "Error_90" in the RS-232C output means that a tolerance value setting error has occurred due to an RS command.
- If an error occurs while you are setting parameters, the preset value, or the tolerance value, the error will be output after the counter display return to the counter value status. However, the error signal will be output immediately to any external output.

6.2.2 Error Cancellation Method

The 3 main error cancellation methods are explained below, but the appropriate method differs depending on the cause.

- Automatic cancellation
- Press [SEL].
- Input an external HOLD signal.

Tips

For details about error messages, see  "6.2.1 List of Error Codes" (page 56).

7 Specifications

7.1 Basic Specifications

Code No.		542-715	542-716
Model No.		LGH-1010-B-EH	LGH-1010C-B-EH
Minimum resolution *1		0.00001 mm (0.01 μm)/0.0001 mm (0.1 μm)	
Measuring range		10 mm	
Indication accuracy (20 °C) *2		0.2 μm	
Repeatability (2σ) *2		0.1 μm	
Retrace error *2		0.1 μm	
Maximum response speed *2		Normal measurement: 700 mm/s Peak detection: 120 mm/s	
Stem diameter		ø15 h6 (0/ -0.011)	
Contact point		Carbide Sø3 (M2.5 x 0.45)/Part No. 901312	
Measuring force	Contact point downwards	0.65 N or less	Approx. 0.12 N
	Contact point horizontal	0.55 N or less	Not available
	Contact point upwards	0.45 N or less	Not available
Available counter		EH Counter (dedicated to LGH-1010-B/Standard accessories)	
Power supply/Power consumption *2		Supplied AC adapter or DC +12 V~+24 V Max. 8.4 W (Max. 700 mA) For commercial power source, ensure at least 1 A power supply per unit.	
Operating temperature/humidity range		0 °C–40 °C/20 % –80 % RH (no condensation) * Recommended operating temperature: 20 °C ± 1 °C	
Storage temperature/humidity range		-10 °C~+60 °C/20 % –80 % RH (no condensation)	
Unit mass		Gage head: Approx. 370 g (including the signal connection cable) Counter: Approx. 900 g (excluding the AC adapter)	
CE marking/UKCA marking		EMC Directive/Electromagnetic Compatibility Regulations: : EN IEC 61326-1 Immunity test requirement : Clause 6.2 Table2 Emission limit : Class B RoHS Directive/The Restriction of the Use of Certain Hazardous Substances in Electrical and Electronic Equipment Regulations: : EN IEC 63000	

*1 The setting can be changed using the counter.

*2 When using the supplied counter



7.2 Outline Dimensional Drawing

7.2.1 Gage Head/Signal Connection Cable

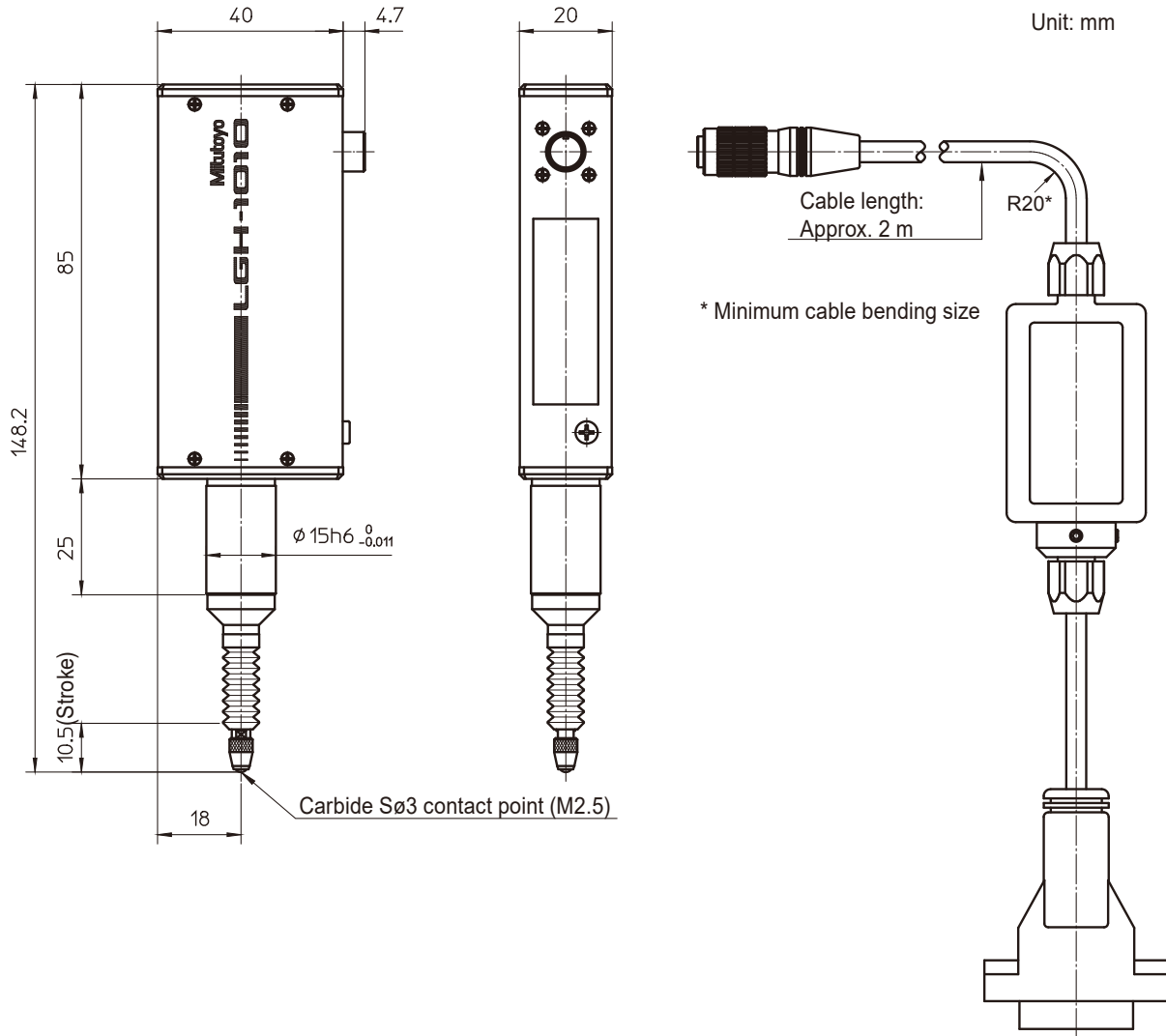

7.2.2 Counter

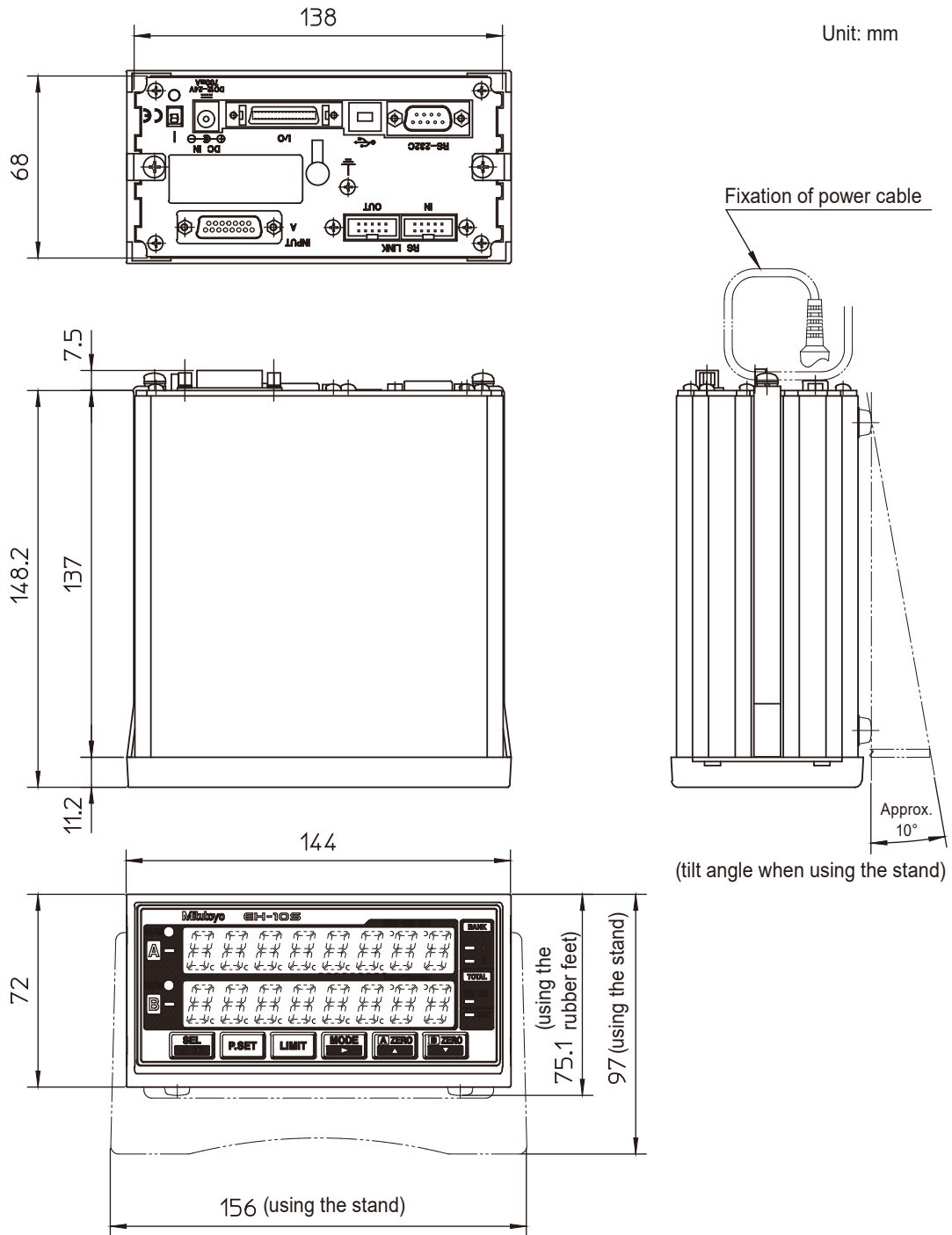

7.3 Option

Code No./ Part No.	Name	Dimensional drawing
971750	LGH measurement stand	page 62
971751	Holder A	page 63
971752	Holder B	page 64
971753	Release for LGH	page 64
02ADB440	I/O output connector (with cover)	-
02ADD950	RS-LINK/Digimatic connection cable (0.5 m)	-
936937	RS-LINK/Digimatic connection cable (1 m)	-
965014	RS-LINK/Digimatic connection cable (2 m)	-
02NGB070	SENSORPAK (software for loading data to PC)	-
21HZA137	I/O CABLE SET FOR SENSORPAK (RS-232C cable)	-
264-505	Digimatic Mini-Processor DP-1VA LOGGER	-
-	Contact points for dial indicator	-
	For details, see the General Catalog.	

■ LGH measurement stand

- External dimensions: 250 (W) x 300 (D) x 365 (H) mm
- Mass: 23 kg
- Maximum measuring range: 0 mm–137 mm

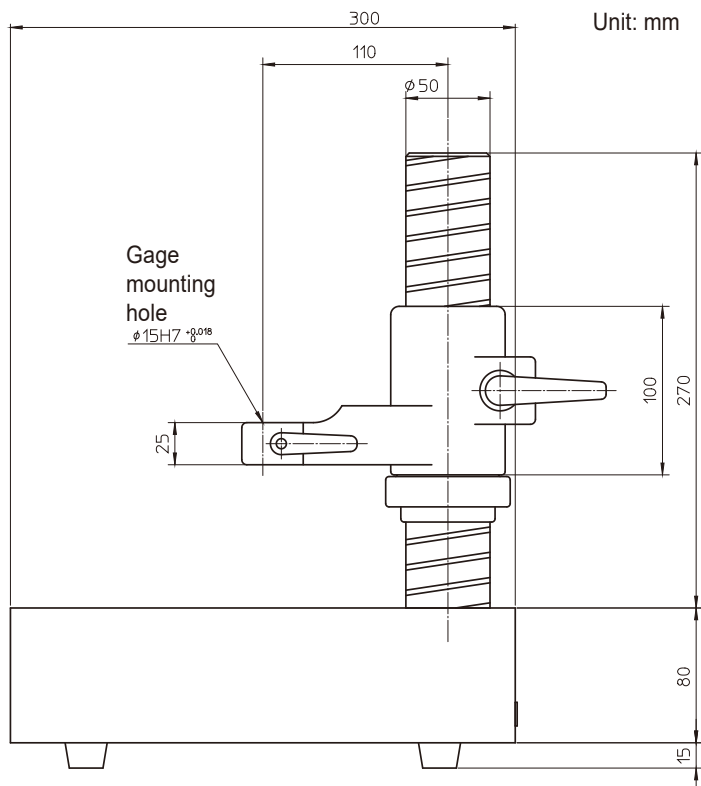

7 Specifications

■ Holder A

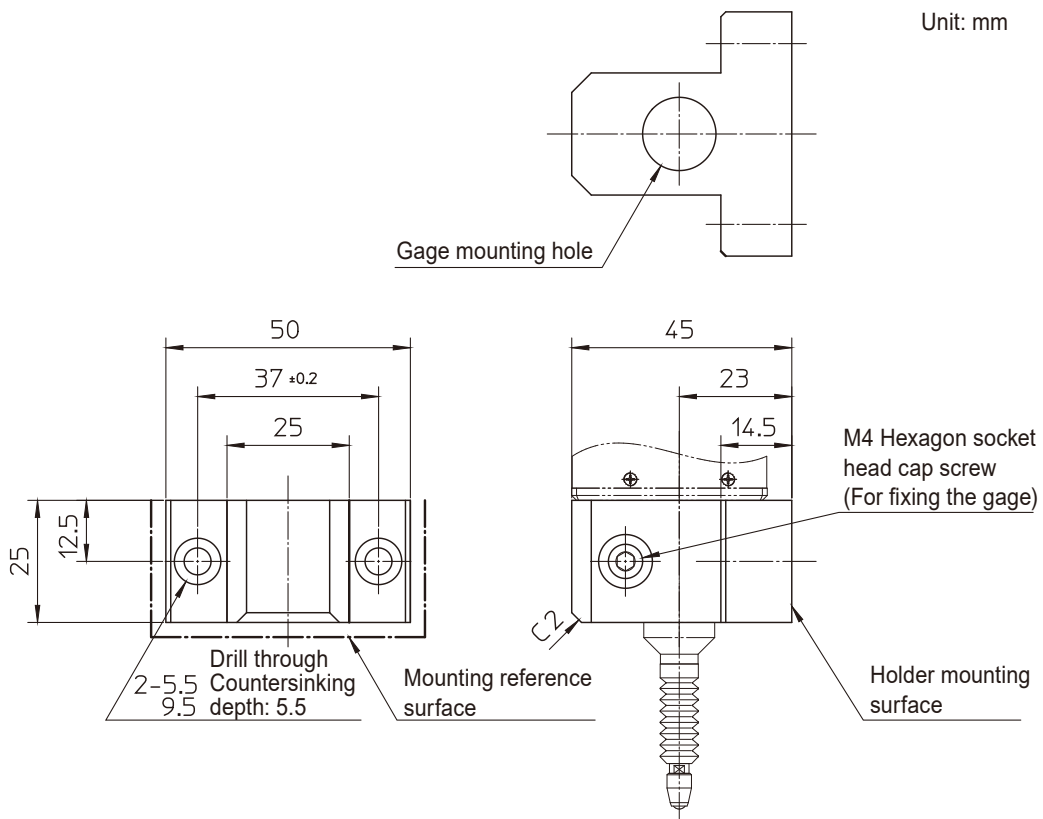

7 Specifications

■ Holder B

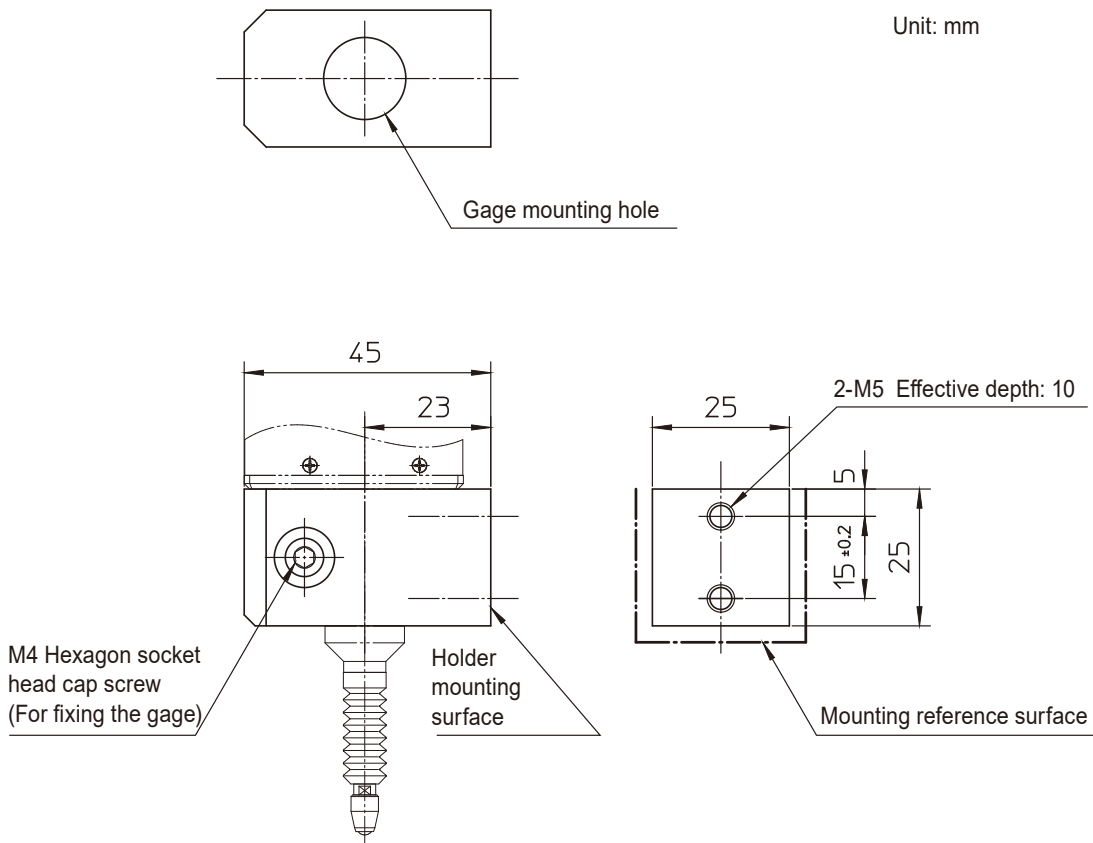

■ Release for LGH

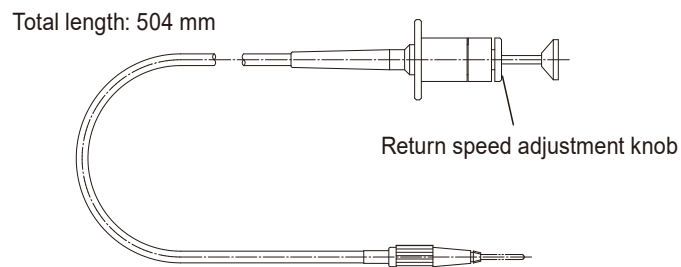

SERVICE NETWORK

*As of May 2025

Europe

Mitutoyo Europe GmbH

Borsigstrasse 8-10, 41469 Neuss, GERMANY
TEL: 49 (0)2137 102-0 FAX: 49 (0)2137 102-351

Mitutoyo CTL Germany GmbH

Von-Gunzert-Strasse 17, 78727 Oberndorf, GERMANY
TEL: 49 (0)7423 8776-0 FAX: 49 (0)7423 8776-99

KOMEG Industrielle Messtechnik GmbH

Zum Wasserwerk 3, 66333 Völklingen, GERMANY
TEL: 49 (0)6898 91110 FAX: 49 (0)6898 911100

Germany

Mitutoyo Deutschland GmbH

Borsigstrasse 8-10, 41469 Neuss, GERMANY
TEL: 49 (0)2137 102-0 FAX: 49 (0)2137 86 85

M³ Solution Center Hamburg

Tempowerkring 9-im HIT-Technologiepark 21079
Hamburg, GERMANY
TEL: 49 (0)40 791894-0 FAX: 49 (0)40 791894-50

M³ Solution Center Berlin

Ernst-Lau-Straße 6, 12489 Berlin, GERMANY
TEL:49(0)30 2611 267 FAX: 49 30 67988729

M³ Solution Center Eisenach

Neue Wiese 4, 99817 Eisenach,GERMANY
TEL: 49 (0)3691 88909-0 FAX: 49 (0)3691 88909-9

M³ Solution Center Ingolstadt

Marie-Curie-Strasse 1A, 85055 Ingolstadt, GERMANY
TEL: 49 (0)841 954920 FAX: 49 (0)841 9549250

M³ Solution Center Leonberg

Am Längenbühl 3, 71229 Leonberg, GERMANY
TEL: 49 (0)7152 6080-0 FAX: 49 (0)7152 608060

Mitutoyo Deutschland GmbH - Small Tool Sales Division

Am Längenbühl 4, 71229 Leonberg, GERMANY
TEL: 49 (0)7152 9237-0 FAX: 49 (0)7152 9237-29

U.K.

Mitutoyo (UK) Ltd. HQ

Joule Road, West Point Business Park,
Andover, Hampshire SP10 3UX, UNITED KINGDOM
TEL: 44 (0)1264 353123 FAX: 44 (0)1264 354883

Coventry M³ Solution Centre

Unit6, Banner Park, Wickmans Drive, Coventry,
West Midlands CV4 9XA, UNITED KINGDOM
TEL: 44 (0)2476 426300

Halifax M³ Solution Centre

Lowfields Business Park, Navigation Close, Elland,
West Yorkshire HX5 9HB, UNITED KINGDOM
TEL: 44 (0)1422 375566

East Kilbride M³ Solution Centre

The Bairds Building, Rankine Avenue, Scottish
Enterprise Technology Park, East Kilbride G75
0QF, UNITED KINGDOM
TEL: 44 (0)1355 581170

France

Mitutoyo France

Paris Nord 2-123 rue de la Belle Etoile, BP 59267
ROISSY EN FRANCE 95957 ROISSY CDG
CEDEX, FRANCE
TEL: 33 (0)149 38 35 00

M³ Solution Center LYON

Parc Mail 523, cours du 3ème millénaire, 69791
Saint-Priest, FRANCE
TEL: 33 (0)149 38 35 70

M³ Solution Center STRASBOURG

Parc de la porte Sud, Rue du pont du péage,
67118 Geispolsheim, FRANCE
TEL: 33 (0)149 38 35 80

M³ Solution Center CLUSES

290 Avenue des Lacs, 74950 Scionzier,
FRANCE
TEL: 33 (0)1 49 38 35 90

M³ Solution Center TOULOUSE

Aeroparc Saint Martin Cellule B08 ZAC de Saint
Martin du Touch 12 rue de Caulet 31300
Toulouse, FRANCE
TEL: 33 (0)1 49 38 42 90

M³ Solution Center RENNES

2, rue Claude Chappe, PA le Vallon - ZAC
Mivoie, 35230 Noyal-Châtillon-sur-Seiche,
FRANCE
TEL: 33 (0)1 49 38 42 10

Italy

Mitutoyo Italiana S.r.l.

Corso Europa, 7 - 20045 Lainate (MI), ITALY
TEL: 39 02 935781 FAX: 39 02 93578255

M³ Solution Center BOLOGNA

Via Stalingrado 67/22D 40128 Bologna, ITALY
TEL: 39 02 93578215

M³ Solution Center CHIETI

Contrada Santa Calcagna - 66020 Rocca S. Giovanni (CH), ITALY
TEL: 39 02 93578280 FAX: 39 02 93578255

M³ Solution Center PADOVA

Via G. Galilei 21/F - 35035 Mestrino (PD), ITALY
TEL: 39 02 93578268 FAX: 39 02 93578255

Netherlands

Mitutoyo Nederland B.V.

Storkstraat 30, 3905 KX Veenendaal,
THE NETHERLANDS
TEL: 31(0)318-534911

Mitutoyo Nederland B.V. / M³ Solution Center Enschede

Institutenweg 50, 7521 PK Enschede,
THE NETHERLANDS
TEL: 31(0)318-534911

Mitutoyo Nederland B.V. / M³ Solution Center Eindhoven

De Run 1115, 5503 LB Veldhoven,
THE NETHERLANDS
TEL: 31(0)318-534911

Mitutoyo Research Center Europe B.V.

De Rijn 18, 5684 PJ Best, THE NETHERLANDS
TEL:31(0)499-320200 FAX:31(0)499-320299

Belgium

Mitutoyo Belgium N.V. / M³ Solution Center Melsele

Schaarbeekstraat 20, B-9120 Melsele, BELGIUM
TEL: 32 (0)3-2540444

Sweden

Mitutoyo Scandinavia AB

Släntvägen 6, 194 61 Upplands Väsby, SWEDEN
TEL: 46 (0)8 594 109 50

Mitutoyo Scandinavia AB / M³ Solution Center Alingsås

Ängsvaktaregatan 3A, 441 38 Alingsås, SWEDEN
TEL: 46 (0)8 594 109 50

Mitutoyo Scandinavia AB / M³ Solution Center Värnamo

Kalkstensvägen 7, 331 44 Värnamo, SWEDEN
TEL: 46 (0)8 594 109 50

Switzerland

Mitutoyo (Schweiz) AG

Steinackerstrasse 35, 8902 Urdorf, SWITZERLAND
TEL: 41 (0)447361150

Mitutoyo (Suisse) SA

Rue Galilée 4, 1400 Yverdon-les Bains, SWITZERLAND
TEL: 41 (0)244259422

Poland

Mitutoyo Polska Sp.z o.o.

Skrzypowa 1, 54-530 Wrocław, POLAND
TEL: 48 (0)71354 83 50 FAX: 48 (0)71354 83 55

Czech Republic

Mitutoyo Česko s.r.o.

Dubská 1626, 415 01 Teplice, CZECH REPUBLIC
TEL: 420 417-514-011 Email: info@mitutoyo.cz

Mitutoyo Česko s.r.o. M³ Solution Center Ivančice

Ke Karlovu 62/10, 664 91 Ivančice, CZECH REPUBLIC
TEL: 420 417-514-011 Email: info@mitutoyo.cz

Mitutoyo Česko s.r.o. M³ Solution Center Ostrava Mošnov

Mošnov 314, 742 51 Mošnov, CZECH REPUBLIC
TEL: 420 417-514-050 Email: info@mitutoyo.cz

Mitutoyo Česko s.r.o. Slovakia Branch

Šoltésovej 346/1, 017 01 Považská Bystrica,
SLOVAKIA
TEL: 421 948-595-590 Email: info@mitutoyo.sk

Hungary

Mitutoyo Hungária Kft.

Galamb József utca 9, 2000 Szentendre, HUNGARY
TEL: 36 (30) 6410210

Romania

Mitutoyo Romania SRL

1A Drumul Garii Odai Street, showroom, Ground Floor, 075100 OTOPENI-ILFOV, ROMANIA
TEL: 40 (0)311012088 FAX: +40 (0)311012089

Showroom in Brasov

Strada Ionescu Crum Nr.1, Brasov Business Park Turnul 1, Mezanin, 500446 Brasov-Judetul Brasov, ROMANIA
TEL/FAX: 40 (0)371020017

Finland

Mitutoyo Scandinavia AB Finnish Branch
Autokeskuksentie 16B, 33960 Pirkkala, FINLAND
TEL: 358 (0)40 355 8498

Austria

Mitutoyo Austria GmbH
Salzburger Straße 260/2 und 260/3, 4600 Wels,
AUSTRIA
TEL: 43 (0)7242 219 998
**Mitutoyo Austria GmbH Goetzis Regional
showroom**
Lastenstrasse 48a, 6840 Götzis, AUSTRIA

Singapore

Mitutoyo Asia Pacific Pte. Ltd.
Head office / M³ Solution Center
24 Kallang Avenue, Mitutoyo Building,
SINGAPORE 339415
TEL:(65)62942211 FAX:(65)62996666

Malaysia

Mitutoyo (Malaysia) Sdn. Bhd.
Kuala Lumpur Head Office / M³ Solution Center
Mah Sing Integrated Industrial Park, 4, Jalan Utarid U5/14,
Section U5, 40150 Shah Alam, Selangor, MALAYSIA
TEL:(60)3-78459318 FAX:(60)3-78459346
Penang Branch office / M³ Solution Center
30, Persiaran Mahsuri 1/2, Sunway Tunas, 11900
Bayan Lepas, Penang, MALAYSIA
TEL:(60)4-6411998 FAX:(60)4-6412998
Johor Branch office / M³ Solution Center
70 (Ground Floor), Jalan Molek 1/28, Taman
Molek, 81100 Johor Bahru, Johor, MALAYSIA
TEL:(60)7-3521626 FAX:(60)7-3521628

Thailand

Mitutoyo (Thailand) Co., Ltd.
Bangkok Head Office / M³ Solution Center
2327 Onnut Road Kwaeng Onnut Khet Suanluang
Bangkok 10250, THAILAND
TEL:(66)2080 3500
Chonburi Branch / M³ Solution Center
7/1, Moo 3, Tambon Bowin, Amphur Sriracha,
Chonburi 20230, THAILAND
TEL:(66)2080 3563 FAX:(66)3834 5788
ACC Branch / M³ Solution Center
122/8, 122/9, Moo 6, Tambon Donhuaroh, Amphur
Muangchonburi, Chonburi 20000, THAILAND
TEL:(66)2080 3565

Indonesia

PT. Mitutoyo Indonesia
Head Office / M³ Solution Center
Jalan Sriwijaya No.26 Desa cibatu Kec. Cikarang
Selatan Kab. Bekasi 17530, INDONESIA
TEL: (62)21-2962 8600 FAX: (62)21-2962 8604

Batam Branch Office
Business Center Adhya Building 3rd Floor Kom-
pleks Permata Niaga Blok A No. 1, Jalan jendral
Sudirman Kelurahan Sukajadi, Kecamatan Bat-
am Kota, Kepulauan Riau 29444, INDONESIA
TEL: (62)-778-4888000

Vietnam

Mitutoyo Vietnam Co., Ltd
Hanoi Head Office / M³ Solution Center
1st & 2nd floor, MHDI Building, No. 60 Hoang Quoc
Viet Road, Nghia Do Ward, Cau Giay District, Hanoi,
VIETNAM
TEL:(84)24-3768-8963 FAX:(84)24-3768-8960

Ho Chi Minh City Branch Office / M³ Solution Center
Unit No. B-00.07, Ground Floor, C1 Building, No.
6, Street D9, An Loi Dong Ward, Thu Duc City,
Ho Chi Minh City, VIETNAM
TEL:(84)28-3840-3489 FAX:(84)28-3840-3498

Hai Phong City Branch Office
Room 511, 5th Floor, Thanh Dat 3 Building, No. 4
Le Thanh Tong Street, May To Ward, Ngo Quyen
District, Hai Phong City, VIETNAM
TEL:(84)22-5398-9909

Philippines

Mitutoyo Philippines, Inc.
Head Office / M³ Solution Center
Unit 1B & 2B LTI, Administration Building 1, Annex 1, North
Main Avenue, Laguna Technopark, Binan Laguna 4024,
PHILIPPINES
TEL/FAX:(63) 49 544 0272

India

Mitutoyo South Asia Pvt. Ltd. Head Office
C-122, Okhla Industrial Area, Phase-I,
New Delhi-110 020, INDIA
TEL: (91) 11-40578485/86

MSA Technical Center
Plot no. 65, Ground Floor, Udyog Vihar, Phase-4 Gurga-
on, Haryana - 122016, INDIA
TEL : (91) 124-2340286/287

Mumbai Region Head office

303, Sentinel Hiranandani Business Park Powai,
Mumbai-400 076, INDIA

TEL: (91) 22-25700684/685/837/839

Pune Office / M³ Solution Center

G4/G5, Pride Kumar Senate, Off. Senapati Bapat
Road, Pune-411 016, INDIA

TEL:(91) 20-25660043/44/45

Ahmedabad Office / M³ Solution Center

A-104 & A-105, First Floor, Solitaire Corporate
Park, Near Divya Bhaskar Press, S.G. Road,
Ahmedabad - 380 015, INDIA

TEL: (91) 079 - 29704902/903

Bengaluru Region Head office / M³ Solution Center

116/117-2, Ground Floor, Sy. No. 93 & 94, 3rd
Phase, Peenya Industrial Area, Bengaluru-560
058, INDIA

TEL: (91) 80-25630946/47/48/49

Coimbatore Office

Regus, Srivari Srimath, 3rd Floor, Door No:1045,
Avinashi Road, Coimbatore - 641 018,INDIA

TEL: (91) 9345005663

Chennai Office / M³ Solution Center

No. 624, Anna Salai Teynampet, Chennai-600 018, INDIA

TEL: (91) 44-24328823/24/25

Kolkata Office

Unit No. 1208,Om Tower, 32,J.L.Nehru Road,
Kolkata-700 071, INDIA

TEL: (91) 33-22267088/40060635/22266817

Taiwan**Mitutoyo Taiwan Co., Ltd. / M³ Solution Center Taipei**

4F., No.71, Zhouzi St., Neihu Dist.,Taipei City 114,
TAIWAN

TEL:886(2)5573-5900 FAX:886(2)8752-3267

Taichung Branch / M³ Solution Center Taichung

1F., No. 299, Gaotie 1st Rd., Wuri Dist., Taichung
City 414, TAIWAN

TEL:886(4)2338-6822 FAX:886(4)2338-6722

Kaohsiung Branch / M³ Solution Center Kaohsiung

1F., No.31-1, Haibian Rd., Lingya Dist.,
Kaohsiung City 802, TAIWAN

TEL:886(7)334-6168 FAX:886(7)334-6160

South Korea**Mitutoyo Korea Corporation****Head Office / M³ Solution Center**

33, Eungyejungang-ro 306beon-gil, Siheung-si,
Gyeonggi-do, 15120 KOREA

TEL:82(31)361-4200 FAX:82(31)361-4201

Busan Office / M³ Solution Center

(3150-3, Daejeo 2-dong) 8,Yutongdanji 1-ro
49beon-gil, Gangseo-gu, Busan, 46721 KOREA

TEL:82(51)324-0103 FAX:82(51)324-0104

Daegu Office / M³ Solution Center

(Galsan-dong, Daegu Business Center), 301-Ho, 217,
Seongseogongdan-ro, Dalseo-gu, Daegu 42704 KOREA

TEL:82(53)593-5602 FAX:82(53)593-5603

China**Mitutoyo Measuring Instruments (Shanghai) Co., Ltd.**

18/F, NEW BUND Shun Tak Center, No.18, Lane
666, West Haiyang Road, Pudong New District,
Shanghai 200124, CHINA

TEL:86(21)5836-0718 FAX:86(21)5836-0717

Suzhou Office / M³ Solution Center China (Suzhou)

1/2 Floor, Building 4, No.175 Songbei Road,
Suzhou Free Trade Zone, Suzhou City, Jiangsu
215000, CHINA

TEL:86(512)6522-1790 FAX:86(512)6251-3420

Wuhan Office / M³ Solution Corner

Room 1701, Wuhan Wanda Center, No. 96,
Linjiang Road, Wuchang District, Wuhan
Hubei 430060, CHINA

TEL:86(27)8544-8631 FAX:86(27)8544-6227

Chengdu Office

Room 1-102, 1st Floor, Unit 1, Building 1, No. 24,
Wannian Road (Wanniancang Cool), Chenghua
District, Chengdu City, Sichuan 610056, CHINA

TEL:86(28)8671-8936 FAX:86(28)8671-9086

Hangzhou Office

Room 329, 3F, Building D, West Square of
Hangzhoudong Railway Station, No. 260 Xin-
feng Road, Shangcheng District, Hangzhou City,
Zhejiang 310002, CHINA

TEL: 86(571)8288-0319 FAX: 86(571)8288-0320

Tianjin Office / M³ Solution Center China (Tianjin)

Room D 12/F, TEDA Building, No.256 Jie-fang
Nan Road Hexi District,Tianjin 300042, CHINA

TEL:86(22)5888-1700 FAX:86(22)5888-1701

Changchun Office

Room 815, 8F, Building A1, Upper East
International No.3000 Dongsheng Street,
Erdao District, Changchun, Jilin, 130031, CHINA

TEL:86(431)8192-6998 FAX:86(431)8192-6998

Chongqing Office

Room 1312, Building 3, Zhongyu Plaza, No.86,
Hongjin Avenue,Longxi Street, Yubei District,
Chongqing, 400000, CHINA

TEL:86(23)6595-9950 FAX:86(23)6595-9950

Qingdao Office

Room 638, 6F, No.192 Zhengyang Road, Chengyang District, Qingdao, Shandong, 266109, CHINA
TEL:86(532)8096-1936 FAX:86(532)8096-1937

Xi'an Office

Room 1503 Jianke Building, No.99 Yanta Road, Beilin District, Xi'an City, Shaanxi 710054, CHINA
TEL:86(29)8538-1380 FAX:86(29)8538-1381

Dalian Office / M³ Solution Center China (Dalian)

Room A-106 Shuijing SOHO, No.16 Harbin Road, Economic Development Zone, Dalian, 116600 CHINA
TEL:86(411)8718 1212 FAX:86(411)8754-7587

Zhengzhou Office

Room 5003, 50th Floor, South Tower of Greenland Centre, No.36 Yulin North Road, Zhengdong New District, Zhengzhou, Henan, 450000, CHINA
TEL:86(371)6097-6436 FAX:86(371)6097-6981

Dongguan Office / M³ Solution Center China (Dongguan)

Room 801, No 65, Chang'an Section Guanchang Road, Chang'an Town, Dongguan City, Guangdong 523841, CHINA
TEL:86(769)8541 7715 FAX:86(769)-8541 7745

Fuzhou Office

Unit 03, 7th floor of East Tower, Sansheng International Center, No.118 Wusi Road, Gulou District, Fuzhou City, Fujian 350001, CHINA
TEL: 86 (591) 8761 8095
FAX: 86 (591) 8761 8096

Changsha Office

Room 2207, Building 1, Shiner International Plaza, No. 88, Kaiyuan Middle Road, Changsha City, Hunan 410100, CHINA
TEL: 86 (731) 8401 9276
FAX: 86 (731) 8401 9376

Changzhou Office

Room 1502, Joint Financial Tower, No.255, Tongjiang North Road, Tianning District, Changzhou City, Jiangsu 2130002, CHINA
TEL:86(519)8815 8319 FAX:86(519)8815 8319

Wenzhou Office

Room 512, Building 4, Xinjingdujiayuan, Sanyang Street, Ouhai District, Wenzhou City, Zhejiang 325014, CHINA
TEL:86(577)8641 5280

Shunde Office

Room 1603, Building 26, Vanke Golden Riverside Plaza Phase II, No.13 Mid DeSheng Road, Shunde District, Foshan City, Guangdong 528300, CHINA
TEL/FAX: 86(757)2228 8621

Hefei Office

UnitB3111-1, 1F, Block B3, Huliabaodi Huiyuan, Heping Road, Yaohai District, Hefei City, Anhui 230001, CHINA
TEL: 86(551)6560 1006

Mitutoyo Measuring Technology (Suzhou) Co., Ltd.

1/2 Floor, Building 4, No.175 Songbei Road, Suzhou Free Trade Zone, Suzhou City, Jiangsu 215000, CHINA
TEL:86(512)6252-2660 FAX:86(512)6252-2580

USA**Mitutoyo America Corporation**

965 Corporate Blvd., Aurora, IL 60502, U.S.A.
TEL:1-(630)820-9666 Toll Free No. 1-888-648-8869
FAX:1-(630)978-3501

Headquarters (Aurora) / M³ Solution Center

965 Corporate Blvd., Aurora, IL 60502, U.S.A.

Seattle (Renton) Office / M³ Solution Center

1000 SW 34th St. Suite G, Renton, WA 98057 U.S.A.
TEL:1-(888)-648-8869

Houston Office / M³ Solution Center

4560 Kendrick Plaza Drive Suite 120 Houston, TX 77032, U.S.A.
TEL:1-(888)-648-8869 FAX:1-(281)227-0937

Cincinnati (Mason) Office / M³ Solution Center

6220 Hi-Tek Ct., Mason, OH 45040, U.S.A.
TEL:1-(888)-648-8869 FAX:1-(513)754-0718

Detroit (Novi) Office / M³ Solution Center

46850 Magellan Drive, Suite 100 Novi, MI 48377, U.S.A.
TEL:1-(888)-648-8869 FAX: 1-(248)-926-0928

Los Angeles (City of Industry) Office / M³ Solution Center

16925 E. Gale Ave., City of Industry, CA 91745, U.S.A.
TEL:1-(888)-648-8869 FAX:1-(626)369-3352

Charlotte (Huntersville) Office / M³ Solution Center

11515 Vanstory Dr., Suite 140, Huntersville, NC 28078, U.S.A.
TEL:1-(888)-648-8869 FAX:1-(704)875-9273

Boston (Marlborough) Office / M³ Solution Center

753 Forest Street, Suite 110, Marlborough, MA 01752, U.S.A.
TEL:1-(888)648-8869 FAX:1-(508)485-0782

West Chester (Ohio) / Metrology Service Center

8876 Beckett road, West Chester, OH 45069, USA

TEL:1-(888)-648-8869

Mitutoyo America Corporation Calibration Lab

965 Corporate Blvd., Aurora, IL 60502, U.S.A.

TEL:1-(888)-648-8869 FAX:1-(630)978-6477

Mitutoyo America Corporation CT-Lab Chicago

965 Corporate Blvd., Aurora, IL 60502, U.S.A.

TEL: 1-(888)-648-8869 FAX: 1-(630)-820-3418

Mitutoyo Research & Development America, Inc.

11533 NE 118th St., Kirkland, WA 98034-7111, U.S.A.

TEL:1-(425)821-3906 FAX:1-(425)821-32280

Mitutoyo Research & Development America, Inc. - California Office

16925 Gale Ave. City of Industry, CA 91745-1806 U.S.A.

TEL: 1-(425)821-3906 FAX: 1-(425)821-3228

Canada

Mitutoyo Canada Inc.

2121 Meadowvale Blvd., Mississauga, Ont. L5N 5N1., CANADA

TEL:1-(905)821-1261 FAX:1-(905)821-4968

Montreal Office

7075 Place Robert-Joncas Suite 129, Montreal, Quebec H4M 2Z2, CANADA

TEL:1-(514)337-5994 FAX:1-(514)337-4498

Brazil

Mitutoyo Sul Americana Ltda.

Head office / M³ Solution Center

Avenida Mimes nº 25 – Loteamento Multivias II, Jardim Ermida I, CEP 13212-216 Jundiaí - SP, BRASIL

TEL: 55 (11) 5643-0004/0041

Filial Curitiba / M³ Solution Center

Rua Sergipe, nº 101, Sala A, Bairro Boneca do Iguaçú, São José dos Pinhais – Paraná – BRASIL CEP 83040120

TEL: 55 (41) 3534-1728

Filial Joinville / M³ Solution Center

Rua Sorocaba, No.265, Bairro Floresta, Joinville, Santa Catarina, BRASIL, CEP 89212-210

TEL: 55 (47) 3025-8062

Filial Porto Alegre / M³ Solution Center

Rua Emilio Boeckel nº 325, Bairro: Flao, São Leopoldo - RS, BRASIL CEP 93020-600

TEL: 55 (51) 3037-9383

Argentina

Mitutoyo Sul Americana Ltda.

Argentina Branch / M³ Solution Center

AV. MITRE 1249 Piso. PB– FLORIDA – BUENOS AIRES ARGENTINA

TEL:54 (11) 4730-1433 FAX:54 (11) 4730-1411

Mexico

Mitutoyo Mexicana, S.A. de C.V.

Industria Eléctrica No.15, Parque Industrial, Naulcalpan de Juárez, Estado de México C.P.53370, MÉXICO

TEL: 52 (01-55) 5312-5612

FAX: 52 (01-55) 5312-3380

Monterrey Office / M³ Solution Center

Blv. Interamericana No. 103, Parque Industrial FINSA, C.P. 66636 Apodaca, N.L., MÉXICO

TEL: 52(01-81) 8398-8227/8228/8242/8244

FAX: 52(01-81) 8398-8226

Tijuana Office / M³ Solution Center

Calle José María Velazco 10501-C, Col. Cd. Industrial Nueva Tijuana, C.P. 22500 Tijuana, B.C., MÉXICO

TEL: 52 (01-664) 647-5024

Querétaro Office / M³ Solution Center

Av. Cerro Blanco No.500-1, Colonia Centro Sur, Querétaro, Querétaro, C.P. 76090, MÉXICO

TEL: 52 (01-442) 340-8018, 340-8019 and 340-8020

FAX: 52 (01-442) 340-8017

Mitutoyo Mexicana, S.A. de C.V. Querétaro Calibration Laboratory

Av. Cerro Blanco 500 30 Centro Sur, Querétaro, Querétaro, C.P. 76090, MÉXICO

TEL: 52 (01-442) 340-8018, 340-8019 and 340-8020

FAX: 52 (01-442) 340-8017

Aguascalientes Office / M³ Solution Center

Av. Aguascalientes No. 622, Local 15 Centro Comercial El Cilindro Fracc. Pulgas Pandas Norte, C.P. 20138, Aguascalientes, Ags. MÉXICO

TEL: 52 (01-449) 174-4140 and 174-4143

Irapuato Office / M³ Solution Center

Boulevard a Villas de Irapuato No. 1460 L.1 Col. Ejido Irapuato C.P. 36643

Irapuato, Gto., MÉXICO

TEL: 52 (01-462) 144-1200 and 144-1400

Revision Record

Date of publication	Revision status	Details of revision
February 1, 2019	Revised Third edition	Completely revised
December 1, 2020	Revised Fourth edition	Revision due to changes of the harmonized European standards, etc.
August 1, 2021	Revised Fifth edition	Additions and changes due to application of the UKCA (UK Conformity Assessed) marking
January 1, 2024	Revised Sixth edition	Revision due to changes of the harmonized European standards, etc.
July 1, 2025	Revised Seventh edition	Change of China RoHS compliance

Mitutoyo Corporation

20-1, Sakado 1-Chome, Takatsu-ku, Kawasaki-shi, Kanagawa 213-8533, Japan
Tel: +81 (0)44 813-8230 Fax: +81 (0)44 813-8231
Home page: <https://www.mitutoyo.co.jp/global.html>

For the EU Directive, Authorized representative and importer in the EU:
Mitutoyo Europe GmbH
Borsigstrasse 8-10, 41469 Neuss, Germany

For the UK Regulation, Authorized representative and importer in the UK:
Mitutoyo (UK) Ltd.
Joule Road, West Point Business Park, Andover, Hampshire SP10 3UX, UNITED KINGDOM