

No. 99MBF101B  
SERVES No. 515

# セラキャリパチェツカ Cera Caliper Checker

ユ-ザ-ズ マニュアル

---

User's Manual

ご使用前にこの「ユーザーズマニュアル」をよくお読みの上、  
正しくお使いください。お読みになった後は、  
いつでも見られる所に必ず保管してください。

Read this User's Manual thoroughly before operating the  
instrument. After reading, retain it close at hand for future reference.

**Mitutoyo**

# User's Manual

---

## Cera Caliper Checker

**Mitutoyo**

# CONTENTS

---

1. OVERVIEW	11
2. AVAILABLE MODELS	11
3. COMPONENTS	11
4. FUNCTIONS	12
5. SPECIFICATIONS	12
6. OPERATION	13
6. 1 Method of Accuracy Checks	13
6. 2 Reference Dimensions	14
7. STANDARD ACCESSORIES	16
8. OPTIONAL ACCESSORIES	16
9. PRECAUTIONS ON HANDLING	16
SERVICE NETWORK	18

## 1. OVERVIEW

The Mitutoyo Cera caliper Checker is a reference standard designed to check the accuracy of calipers and height gages. It has employed ceramic (ZrO<sub>2</sub>) reference blocks and base block in order to enhance the abrasion resistance of the measuring surfaces. This allows the Cera caliper Checker to maintain its high measuring accuracy for long period of time. In order to obtain the best possible performance and longest service life of your Cera caliper Checker, read this user's manual carefully prior to operation.

## 2. AVAILABLE MODELS

Code. No.	Name	Measuring range
515 - 555	CC - 300C	20 ~ 300mm
515 - 556 - 2	CC - 600C	20 ~ 600mm
515 - 565	CC - 12" C	1 ~ 12"

## 3. COMPONENTS

The Cera caliper Checker consists of the following components shown below.

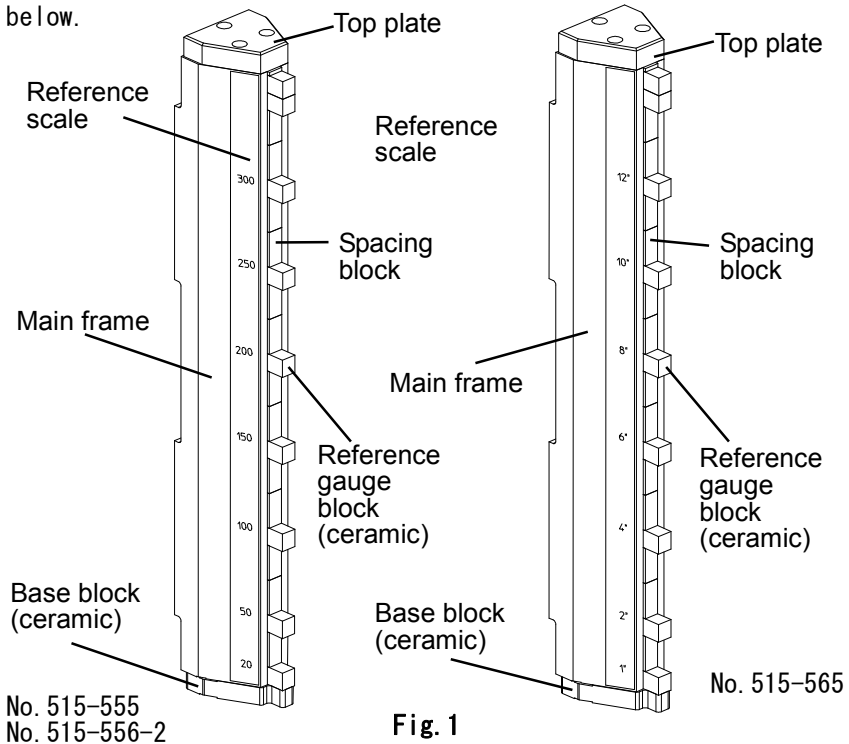

Fig. 1

#### 4. FUNCTIONS

Code.No. Item	515-555	515-556-2	515-565
Name	Cera Caliper Checker CC-300C	Cera Caliper Checker CC-600C	Cera Caliper Checker CC-12"C
Measuring range			
Outside measurement	20, 50, 100, 150 200, 250, 300	20, 50, 100, 150 200, 250, 300, 350, 400, 450, 500, 550, 600	1", 2", 4", 6", 8", 10", 12"
Inside measurement	20, 50, 100, 150 200, 250, 300	20, 50, 100, 150, 200, 250, 300, 350, 400, 450, 500, 550, 600	1", 2", 4", 6", 8", 10", 12"
Height measurement	20, 50, 100, 150 200, 250, 300	20, 50, 100, 150 200, 250, 300, 350, 400, 450, 500, 550, 600	1", 2", 4", 6", 8", 10", 12"
Mass	Approx.4kg	Approx.8.5kg	8.8lbs.

#### 5. SPECIFICATIONS

Code.No. Item	515-555	515-556-2	515-565
Deviation of central length	$\pm 0.005\text{mm}$	$\pm 0.005\text{mm}$ (for a length 300mm or less) $\pm 0.007\text{mm}$ (for a length more than 300mm)	$\pm 0.0002''$
Variation in length	0.002mm	0.002mm (for a length 300mm or less) 0.004mm (for a length more than 300mm)	0.00008"
Surface roughness of measuring surfaces	Ry 0.08	Ry 0.08	Ry 0.08
Hardness of gauge blocks	HV 1350	HV 1350	HV 1350

## 6. OPERATION

This instrument is designed to check the accuracy of calipers and height gages. In each type of use, please note the following points.

### 6. 1 Method of Accuracy Checks

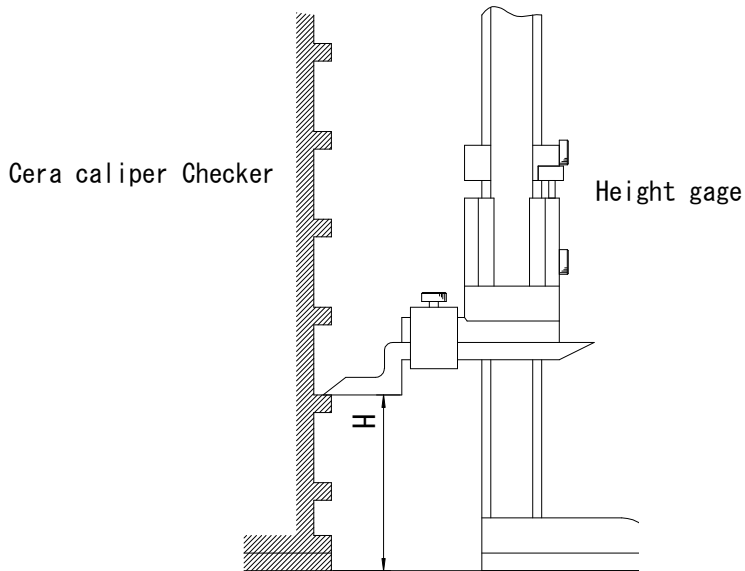

Fig. 2 Checking the height gage accuracy

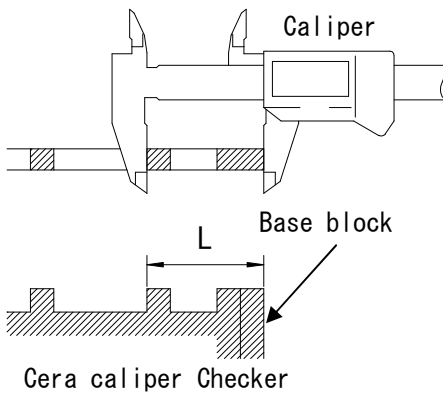

Fig. 3 Checking the caliper  
(outside measurement accuracy)

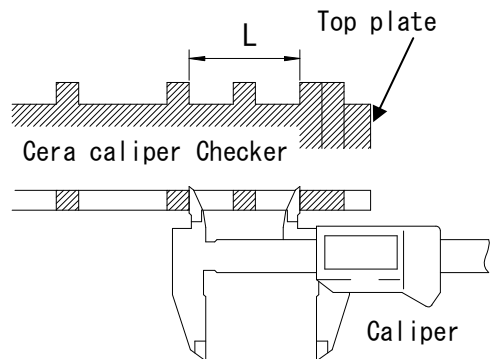
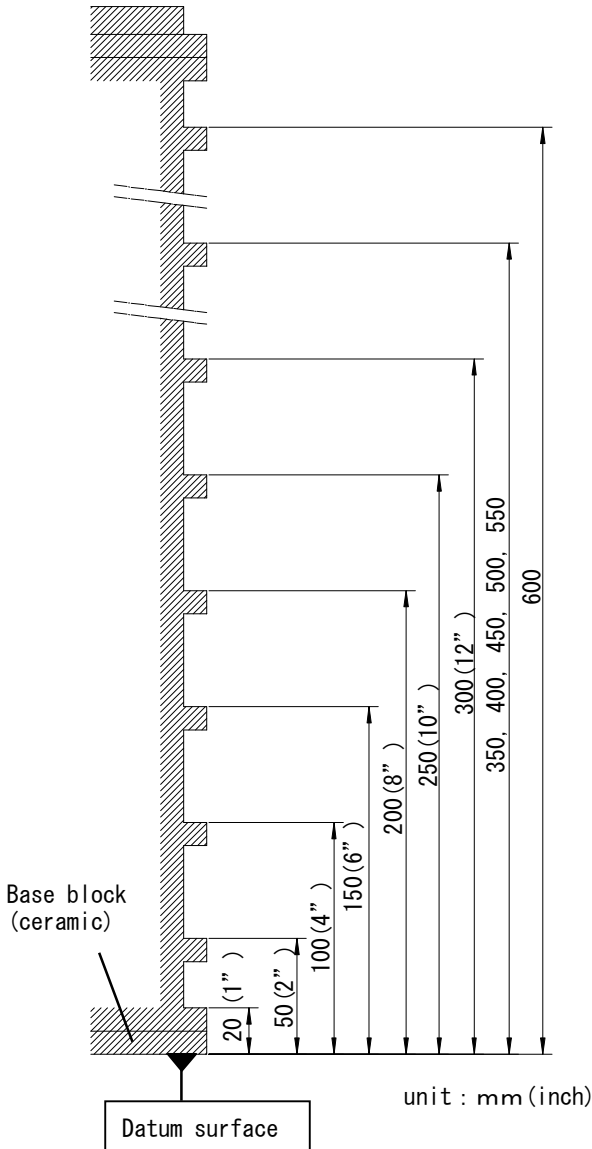

Fig. 4 Checking the caliper  
(inside measurement accuracy)

## 6. 2 Reference Dimensions

- Reference Dimensions for checking the height gage or caliper (outside-measurement accuracy)



- CC-300C Measuring range  
20, 50, 100, 150,  
200, 250, 300

- CC-600C Measuring range  
20, 50, 100, 150,  
200, 250, 300, 350,  
400, 450, 500, 550,  
600

- CC-12" C Measuring range  
1" , 2" , 4" , 6" ,  
8" , 10" , 12"

Fig. 5

● Reference Dimensions for checking the caliper  
(inside-measurement accuracy)

• CC-300C Measuring range

20, 50, 100, 150, 200, 250, 300

• CC-12" C Measuring range

1" , 2" , 4" , 6" , 8" , 10" , 12"

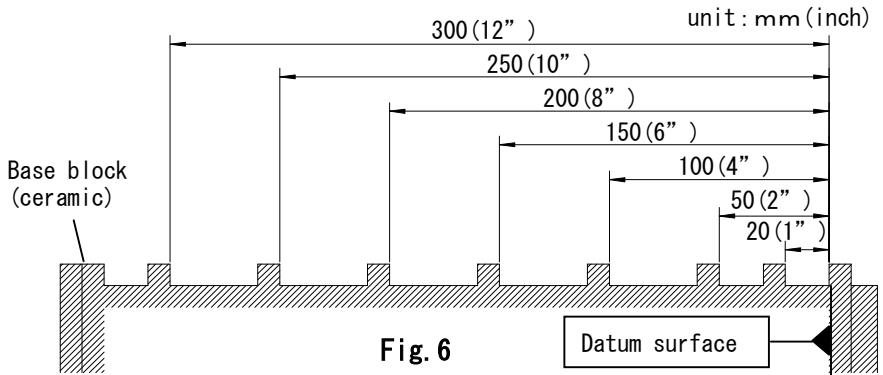

• CC-600C Measuring range

20, 50, 100, 150, 200, 250, 300, 350, 400,  
450, 500, 550, 600

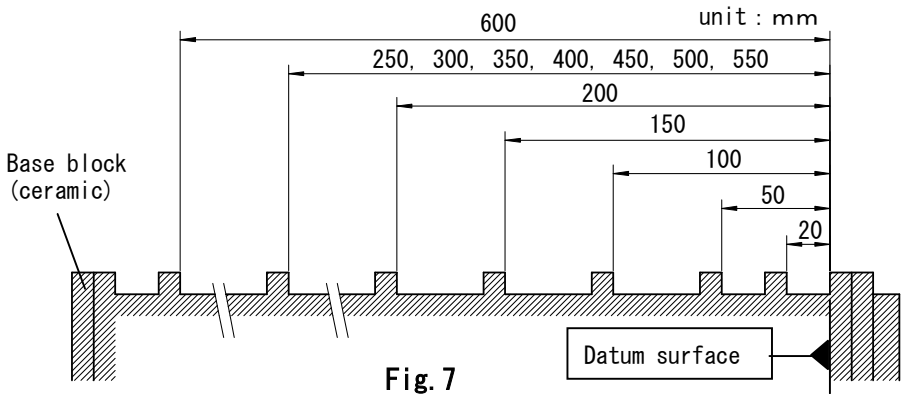



## 7. STANDARD ACCESSORIES

- 1) Vinyl cover
- 2) User' s Manual
- 3) Inspection certificate

## 8. OPTIONAL ACCESSORIES

Wooden box No. 515-555, No. 515-565 . . . Order No. 602162  
No. 515-556-2 . . . . . Order No. 602164

## 9. PRECAUTIONS ON HANDLING

- 1) Handle with care so that it is not subjected to impact when you carry it or place it on the surface plate.
- 2) Before starting operation, wipe off dust from the measuring surfaces of the gauge blocks with a clean cotton cloth or gauze. After use, lightly apply high-quality anti-corrosive oil to the spacing blocks.
- 3) Before you use the Cera Caliper Checker on a surface plate, wipe the surface plate clean.
- 4) As the gauge blocks and spacing blocks have been precisely assembled and adjusted at the factory, never disassemble the Cera Caliper Checker for re-adjustment.  
Should a malfunction occur on the Cera Caliper Checker, leave it as-is and contact your dealer or the nearest Mitutoyo sales office.

# SERVICE NETWORK

## Mitutoyo America Corporation

### Illinois Repair Service

958 Corporate Blvd., Aurora, IL. 60502-9176, U.S.A.  
TEL: (630) 820-3334 FAX: (630) 820-2530

### M<sup>3</sup> Solution Center Michigan

44768 Helm Street, Plymouth, MI 48170, U.S.A.  
TEL: (734) 459-2810 FAX: (734) 459-0455

### Los Angeles Repair Service

16925 East Gale Ave., City of Industry, CA 91745, U.S.A.  
TEL: (626) 961-9661 FAX: (626) 333-8019

### for Advanced Technical Support Service

### M<sup>3</sup> Solution Center Indiana:

TEL: (317) 577-6070 FAX: (317) 577-6080

### M<sup>3</sup> Solution Center Massachusetts:

TEL: (978) 692-7474 FAX: (978) 692-9729

### M<sup>3</sup> Solution Center North Carolina:

TEL: (704) 875-8332 FAX: (704) 875-9273

## Mitutoyo Canada Inc.

2121 Meadowvale Blvd., Mississauga, Ont. L5N 5N1, CANADA  
TEL: (905) 821-1261 to 3 FAX: (905) 821-4968

## Mitutoyo Sul Americana Ltda.

AV. João Carlos da Silva Borges, 1240, CEP 04726-002  
Santo Amaro P.O. Box 4255 São Paulo, BRASIL  
TEL: (011) 5643-0000 FAX: (011) 5641-3722

### Argentina Branch

Av. Mitre 891/899 -C.P.(B1603CQJ) Vicente Lopez-Pcia.  
Buenos Aires, ARGENTINA  
TEL: (011) 4730-1433 FAX: (011) 4730-1411

## Mitutoyo Mexicana S.A. de C.V.

Prof. Ind. Elctrica #15 Col. Parq. Ind. Naulcalpan C.P.53370,  
Naulcalpan, Edo. de Mexico, MEXICO  
TEL: 52-55-5312-5612 FAX: 52-55-5312-3380

## Mitutoyo Meßgeräte GmbH

Borsigstr. 8-10, 41469 Neuss F.R. GERMANY  
TEL: (02137) 102-0 FAX: (02137) 8685

## Mitutoyo Polska Sp.z o.o.

ul. Minska, nr54-56, Wroclaw, POLAND  
TEL: (48) 71-3548350 FAX: (48) 71-3548355

## Mitutoyo Cesko s.r.o

Dubská 1626, 415 01 Teplice, CZECH REPUBLIC  
TEL: (420) 417 579 866 FAX: (420) 417 579 867

## Mitutoyo Hungaria Kft.

Nélochmetvölöchlgyi úlloch 97. H-1124 Budapest,  
XII HUNGARY  
TEL: (00361) 2141447 FAX: (00361) 2141448

## Mitutoyo Nederland B.V.

Postbus 550, Landjuweel 35, 3905 PE Veenendaal,  
NETHERLANDS  
TEL: 0318-534911 FAX: 0318-534913

## Mitutoyo Scandinavia A.B.

Box 712, Slåntvågen 6, 194 27 Upplands-Väsby, SWEDEN  
TEL:(07) 6092135 FAX: (07) 6092410

## Mitutoyo Belgium N.V.

Hogenakkerhoekstraat 8, 9150 Kruikebeke, BELGIUM  
TEL: 03-254 04 04 FAX: 03-254 04 05

## Mitutoyo France S.A.R.L.

123, rue de la Belle Etoile, B.P. 50267-Z.I. Paris Nord II 95957  
Roissy CDG Cedex, FRANCE  
TEL: (01) 49 38 35 00 FAX: (01) 49 38 35 35

### Mitutoyo France S.A.R.L., Agence de Lyon

TEL: (04) 78 26 98 07 FAX: (04) 72 37 16 23

### Mitutoyo France S.A.R.L., Agence de Strasbourg

TEL: (03) 88 67 85 77 FAX: (03) 88 67 85 79

## Mitutoyo Italiana S.R.L.

Corso Europa No.7, 20020 Lainate, Milano, ITALY  
TEL: (02) 935781 FAX: (02) 9373290

## Mitutoyo Schweiz AG

Steinackerstrasse 35, 8902 Urdorf-Zürich, SWITZERLAND  
TEL: (44) 7361150 FAX: (44) 7361151

## Mitutoyo (U.K.) Ltd.

Joule Road, West Point Business Park, Andover,  
Hampshire SP10 3UX UNITED KINGDOM  
TEL: (01264) 353123 FAX: (01264) 354883

## Mitutoyo Asia Pacific Pte. Ltd.

### Regional Headquarters

24 Kallang Avenue, Mitutoyo Building, SINGAPORE 339415  
TEL: (65) 6294 2211 FAX: (65) 6299 6666

### Mitutoyo (Malaysia) Sdn. Bhd.

Mah Sing Integrated Industrial Park 4, Jalan Utarid U5/14, Section  
U5, 40150 Shah Alam, Selangor Darul Ehsan, MALAYSIA  
TEL: (60) 3-7845 9318 FAX: (60) 3-7845 9346

### Mitutoyo Thailand Co.,Ltd.

76/3, Chaengwattana Road, Anusawaaree, Bangkaen,  
Bangkok 10220, THAILAND  
TEL: (66) 2-521 6130 FAX: (66) 2-521 6136

### PT. Mitutoyo Indonesia

Ruko Mall Bekasi Fajar Blok A6&A7 MM2100 Industrial  
Town  
Cikarang Barat Bekasi 17520 Indonesia  
TEL:(62) 21-898 0841 FAX:(62) 21-898 0842

### Representative Office

#### Vietnam (Ho Chi Minh City):

TEL: (84) 8-3517 4561 FAX: (84) 8-3517 4582

#### Vietnam (Hanoi):

TEL: (84) 4-768 8963 FAX: (84) 4-768 8960

#### Philippines:

TEL: (63) 2-842 9305/6 FAX: (63) 2-842 9307

## Mitutoyo South Asia Pvt. Ltd.

C-122, Okhla Industrial Area, Phase-I,  
New Delhi-110 020, INDIA  
TEL: 91-11-26372090 FAX: 91-11-26372636

## Mitutoyo Taiwan Co.,Ltd.

4F., No.71, Zhouzi St, Neihsu District,  
Taipei City114, TAIWAN, R.O.C.  
TEL: (02) 8752-3266 FAX: (02) 8752-3267

## Mitutoyo Korea Corporation

KOCOM Building 2F, #260-7, Yeom Chang-Dong, Kang  
Seo-Gu, Seoul, 157-040, KOREA  
TEL: (02) 3661-5546 to 7 FAX: (02) 3661-5548

## Mitutoyo (Beijing) Liaison Office

#1011, Beijing Fortune Bldg., No.5 Dong Sanhuan Bei-Lu  
Chaoyang District, Beijing, 100004, P.R. CHINA  
TEL: 010-65908505 FAX: 010-65908507

## Mitutoyo Measuring Instruments Co., Ltd.

### Shanghai:

Room C 13/F, Nextage Business Center No.1111 Pudong South  
Road, Pudong New District, Shanghai, 200120, P.R. CHINA  
TEL: 021-5836-0718 FAX: 021-5836-0717

### Suzhou:

46, Bai Yu Street, Suzhou, 215021, P.R. CHINA  
TEL: 0512-62522660 FAX: 0512-62522580

### Tianjin:

No.16 Heiniucheng -Road, Hexi - District,  
Tianjin, 300210, P.R. CHINA  
TEL: 022-8558-1221 FAX: 022-8558-1234



# 株式会社 ミットヨ

神奈川県川崎市高津区坂戸 1-20-1 〒213-8533

<http://www.mitutoyo.co.jp>

## Mitutoyo Corporation

20-1, Sakado 1-Chome, Takatsu-ku, Kawasaki-shi, Kanagawa 213-8533, Japan

Tel: +81 (0)44 813-8230 Fax: +81 (0)44 813-8231

Home page: <http://www.mitutoyo.co.jp/global.html>