



Separate Type Absolute Linear Scale

ABS ST1300 Series

User's Manual - Instructions for use -

Read this document thoroughly before operating the product. After reading, retain it close at hand for future reference. This English language version of the document contains the original instructions.

No. 99MBE084B4
Date of publication: January 1, 2021 (1)



■ Correspondence of product names and model numbers

Product name	Model number
Separate Type Absolute Linear Scale	ABS ST130*A
	ABS ST134*A
	ABS ST135*
	ABS ST137*A
	ABS ST138*A

■ Notice regarding this document





- Mitutoyo Corporation assumes no responsibilities for any damage to the product, caused by its use not conforming to the procedure described in this document.
- Upon loan or transfer of this product, be sure to attach this document to the product.
- In the event of loss or damage to this document, immediately contact a Mitutoyo sales office or your dealer.
- Before operation of the product, thoroughly read this document to comprehend its contents.
- Particularly, for full understanding of information, carefully read "Safety Precautions" and "Precautions for Use" at the outset of this document before using the product.
- The contents in this document are based on the information current as of January, 2021.
- No part or whole of this document may be transmitted or reproduced by any means without prior written permission of Mitutoyo Corporation.
- The corporation, organization and product names that appear in this document are their trademarks or registered trademarks.

©2019-2021 Mitutoyo Corporation. All rights reserved.



CONVENTIONS USED IN MANUALS

Conventions used in Mitutoyo's User's Manual are roughly divided into three types (safety reminders, prohibited and mandatory actions, and referential information and locations). Moreover, these conventions include general warnings and specific warnings. Specific warning symbols are provided with concrete pictograms inside of them.

■ Safety reminder conventions and wording warning against potential hazards

 DANGER	Indicates an immediately hazardous situation which, if not avoided, will result in serious injury or death.
 WARNING	Indicates a potentially hazardous situation which, if not avoided, could result in serious injury or death.
 CAUTION	Indicates a potentially hazardous situation which, if not avoided, may result in minor injury.
 NOTICE	Indicates a potentially hazardous situation which, if not avoided, may result in property damage.
	Alerts the user to a specific hazardous situation that means "Caution, risk of electric shock".

■ Conventions and wording indicating prohibited and mandatory actions

	Indicates concrete information about prohibited actions.
	Indicates concrete information about mandatory actions.
	Indicates that grounding needs to be implemented.

■ Conventions and wording indicating referential information or referential locations

Tips Indicates referential information such as that for when the operating methods and procedures which are printed in these sentences are to be applied to specific conditions.



Indicates referential locations if there is information that should be referred to in this document or an extraneous User's Manual.

E.g.: For details about XX, see  "1.2 System Configuration and Name of Each Part" (page 1).

Safety Precautions

Observe the following descriptions to make full use of the performance of this product:

NOTICE

- Read this document thoroughly before operating the system to use it properly.
- Before connecting this product to the machine main unit, make sure that the power for the control unit is turned off.
- To maintain the shielding effect, firmly tighten the screws on the connectors of each connecting cable.
- To prevent defective contacts, do not touch the connecting terminals of the connectors with bare hands.

Precautions for Use

■ General safety precautions

- This product is a measuring instrument.
Do not use this product for any other purpose than measuring.
- This is an industrial product.
Do not use this product for any other purpose than industrial use.
- This product is a precision instrument.
Handle this product with extra care. Do not apply any strong impact or excessive force to the parts during use.

■ Required environment for installation

● Vibration

To install this product onto the machine main unit, select a location where there is as little vibration as possible.

If the scale unit is used for an extended period of time on a machine where there is a substantial amount of vibration, the built-in precision parts may be damaged, thereby adversely influencing the performance of the unit.

● Shock, dust, water protection

To protect the scale main unit from being directly exposed to machining oil and chips, or from being bumped by a workpiece, etc., prepare a cover that protects the entire scale main unit.

● Ambient temperature and humidity

This product should be operated in an environment where the temperature is 0 °C–50 °C and where the relative humidity is 20 %RH–80 %RH (non condensation). Do not use this product in a place where sudden changes in temperature or humidity are observed.

Electromagnetic Compatibility (EMC)

This product complies with the EU EMC Directive. Note that in environments where electromagnetic interference exceeds EMC requirements defined in this directive, appropriate countermeasures are required to ensure product performance.

This is an industrial product. Not intended for use in a residential environment. Use of this product in a residential environment may cause an electromagnetic interference with other instruments. In such a case, appropriate measures against electromagnetic interference are required.

Export Control Compliance

This product falls into the Catch-All-Controlled Goods and/or Catch-All-Controlled Technologies (including Programs) under Category 16 of Appended Table 1 of Export Trade Control Order or under Category 16 of Appended Table of Foreign Exchange Control Order, based on Foreign Exchange and Foreign Trade Act of Japan.

If you intend re-export of the product from a country other than Japan, re-sale of the product in a country other than Japan, or re-provision of the technology (including program), you are obligated to observe the regulations of your country.

Also, if an option is added or modified to add a function to this product, this product may fall under the category of List-Control Goods and/or List-Control Technology (including Programs) under Category 1 - 15 of Appended Table 1 of the Export Trade Control Order or under Category 1 - 15 of the Appended Table of Foreign Exchange Control Order, based on Foreign Exchange and Foreign Trade Act of Japan. In that case, if you intend re-export of the product from a country other than Japan, re-sale of the product in a country other than Japan, or re-provision of the technology (including program), you are obligated to observe the regulations of your country. Please contact Mitutoyo in advance.

Notes on Export to EU Member Countries

When you intend exporting of this product to any of the EU member countries, it may be required to provide User's Manual(s) in English and EU Declaration of Conformity in English (under certain circumstances, User's Manual(s) in the destination country's official language and EU Declaration of Conformity in the destination country's official language). For detailed information, please contact Mitutoyo in advance.

Disposal of Products outside the European Union and Other European Countries

Please follow the official instruction in each community and country.

Disposal of Old Electrical & Electronic Equipment (Applicable in the European Union and Other European Countries with Separate Collection Systems)



This symbol on the product or on its packaging is based on WEEE Directive (Directive on Waste Electrical and Electronic Equipment), which is a regulation in EU member countries, and this symbol indicates that this product shall not be treated as household waste.

■ To reduce the environmental impact and minimize the volume of landfills, please cooperate in reuse and recycle.

For how to dispose of the product, please contact your dealer or the nearest Mitutoyo sales office.

China RoHS Compliance Information

This product meets China RoHS requirements. See the table below.

产品中有害物质的名称及含量

部件名称	有害物质					
	铅 (Pb)	汞 (Hg)	镉 (Cd)	六价铬 (Cr(VI))	多溴联苯 (PBB)	多溴二苯醚 (PBDE)
本体	○	○	○	○	○	○
电气设备部分	×	○	○	○	○	○
配件	○	○	○	○	○	○

本表格依据 SJ/T 11364 的规定编制。

○: 表示该有害物质在该部件所有均质材料中的含量均在 GB/T 26572 规定的限量要求以下。

×: 表示该有害物质至少在该部件的某一均质材料中的含量超出 GB/T 26572 规定的限量要求。



环保使用期限标识是根据《电器电子产品有害物质限制使用管理办法》以及《电子电气产品有害物质限制使用标识要求(SJ/T11364-2014)》制定的,适用于中国境内销售的电子电气产品的标识。

电器电子产品只要按照安全及使用说明内容在正常使用情况下,从生产日期算起,在此期限内产品中含有的有毒有害物质不致发生外泄或突变,不致对环境造成严重污染或对其人身、财产造成严重损害。

产品使用后,要废弃在环保使用年限内或者刚到年限的产品,请根据国家标准采取适当的方法进行处置。

另外,此期限不同于质量/功能的保证期限。

Warranty

In the event that this product should prove defective in workmanship or material, within one year from the date of original purchase for use, it will be repaired or replaced, at Mitutoyo's option, free of charge upon its prepaid return to Mitutoyo, without prejudice to the provisions of the Mitutoyo Software End User License Agreement.

If this product fails or is damaged for any of the following reasons, it will be subject to a repair charge, even if it is still under warranty.

- Failure or damage owing to fair wear and tear
- Failure or damage owing to inappropriate handling, maintenance or repair, or to unauthorized modification
- Failure or damage owing to transport, dropping, or relocation of the instrument after purchase
- Failure or damage owing to fire, salt, gas, abnormal voltage, lightning surge, or natural disaster
- Failure or damage owing to use in combination with hardware or software other than those designed or permitted by Mitutoyo
- Failure or damage owing to use in ultra-hazardous activities

This warranty is effective only where the instrument is properly installed and operated in conformance with the instructions in this manual within the original country of the installation.

EXCEPT AS SPECIFIED IN THIS WARRANTY, ALL EXPRESS OR IMPLIED CONDITIONS, REPRESENTATIONS, AND WARRANTIES OF ANY NATURE WHATSOEVER INCLUDING, WITHOUT LIMITATION, ANY IMPLIED WARRANTY OF MERCHANTABILITY, FITNESS FOR A PARTICULAR PURPOSE, NONINFRINGEMENT OR WARRANTY ARISING FROM A COURSE OF DEALING, USAGE, OR TRADE PRACTICE, ARE HEREBY EXCLUDED TO THE MAXIMUM EXTENT ALLOWED BY APPLICABLE LAW.

You assume all responsibility for all results arising out of its selection of this product to achieve its intended results.

Disclaimer

IN NO EVENT WILL MITUTOYO, ITS AFFILIATED AND RELATED COMPANIES AND SUPPLIERS BE LIABLE FOR ANY LOST REVENUE, PROFIT, OR DATA, OR FOR SPECIAL, DIRECT, INDIRECT, CONSEQUENTIAL, INCIDENTAL, OR PUNITIVE DAMAGES HOWEVER CAUSED AND REGARDLESS OF THE THEORY OF LIABILITY ARISING OUT OF THE USE OF OR INABILITY TO USE THIS PRODUCT EVEN IF MITUTOYO OR ITS AFFILIATED AND RELATED COMPANIES AND/ OR SUPPLIERS HAVE BEEN ADVISED OF THE POSSIBILITY OF SUCH DAMAGES.

If, notwithstanding the foregoing, Mitutoyo is found to be liable to you for any damage or loss which arises out of or is in any way connected with use of this product by you, in no event shall Mitutoyo's and/or its affiliated and related companies' and suppliers' liability to you, whether in contract, tort (including negligence), or otherwise, exceed the price paid by you for the product only.

The foregoing limitations shall apply even if the above-stated warranty fails of its essential purpose. BECAUSE SOME COUNTRIES, STATES OR JURISDICTIONS DO NOT ALLOW THE EXCLUSION OR THE LIMITATION OF LIABILITY FOR CONSEQUENTIAL OR INCIDENTAL DAMAGES, IN SUCH COUNTRIES, STATES OR JURISDICTIONS, MITUTOYO'S LIABILITY SHALL BE LIMITED TO THE EXTENT PERMITTED BY LAW.

About This Document

■ Positioning of this document in document map

● For linear scale

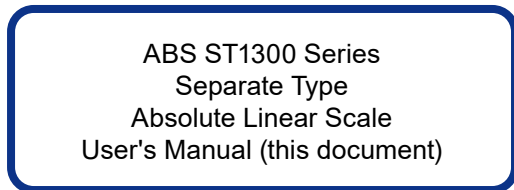

● For software

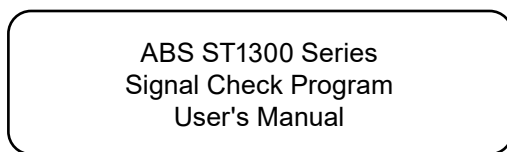

■ Intended readers and purpose of this document

● Intended readers

This document is intended for first-time users of ABS ST1300 Series Separate Type Absolute Linear Scale.

Readers are assumed to be able to understand instructions by reading technical drawings.

● Purpose

The purpose of this document is to help you understand the ABS ST1300 Series Separate Type Absolute Linear Scale.

Contents

CONVENTIONS USED IN MANUALS	i
Safety Precautions	ii
Precautions for Use	ii
Electromagnetic Compatibility (EMC)	iii
Export Control Compliance	iii
Notes on Export to EU Member Countries	iii
Disposal of Products outside the European Union and Other European Countries	iii
Disposal of Old Electrical & Electronic Equipment (Applicable in the European Union and Other European Countries with Separate Collection Systems)	iv
China RoHS Compliance Information	iv
Warranty	v
Disclaimer	vi
About This Document	vii
Contents	viii
1 Overview	1
1.1 Features	1
1.2 System Configuration and Name of Each Part	1
1.2.1 Specifications for Fixing at Both Ends	2
1.2.2 Specifications for Fixing with Double-Sided Tape	3
1.2.3 Specifications for Fixing at the Center	4
1.2.4 Detection Unit	5
1.3 The Flow of Main Tasks	6
1.3.1 Preliminary Preparation	6
1.3.2 Installation onto the Machine Main Unit	6
2 Setup for Installation	9
2.1 Checking the Equipment Model	9
2.1.1 System Parameters	10
2.2 Designing the Scale Mounting Surface	11
2.2.1 Mounting the Scale with the Specifications for Fixing at Both Ends	11
2.2.2 Mounting the Scale with the Specifications with Double-Sided Tape	12

2.2.3	Mounting the Scale with the Specifications for Fixing at the Center	13
2.3	Designing the Detector Bracket	14
3	Installation onto the Machine Main Unit.....	15
3.1	Checking the Package Contents	15
3.1.1	Specifications for Fixing at Both Ends	15
3.1.2	Specifications for Fixing with Double-Sided Tape	16
3.1.3	Specifications for Fixing at the Center	17
3.2	Mounting the Scale Main Unit.....	19
3.2.1	Specifications for Fixing at Both Ends	19
3.2.2	Specifications for Fixing with Double-Sided Tape	27
3.2.3	Specifications for Fixing at the Center	34
3.3	Mounting the Detector Bracket and Detector	37
3.4	Connecting the Feedback Cable and Checking the Signals	41
3.5	Handling the Cables and Checking the Mounting State.....	41
3.5.1	Handling the Cables	41
3.5.2	Checking the Mounting and Adjustment States	42
3.5.3	Putting the Protection Cover	42
4	Specifications	45
4.1	Specifications	45
4.1.1	Specifications for Fixing at Both Ends	45
4.1.2	Specifications for Fixing with Double-Sided Tape	46
4.1.3	Specifications for Fixing at the Center	47
4.2	Relationship between the Resolution, Maximum Effective Length, and Maximum Response Speed	48
4.2.1	Resolution: 0.01 μm	48
4.2.2	Resolution: 0.001 μm	48
4.3	Data Zero Position and Counting Direction	49
4.4	Production of a Feedback Cable	50
4.4.1	Connection Diagram for ABS ST1301A/ABS ST1302A	50
4.4.2	Connection Diagram for ABS ST1341A/ABS ST1342A	51
4.4.3	Connection Diagram for ABS ST1351/ABS ST1352	51
4.4.4	Connection Diagram for ABS ST1371A/ABS ST1372A	52
4.4.5	Connection Diagram for ABS ST1381A/ABS ST1382A	52
4.4.6	Calculation of Feedback Cable Length	53
4.5	Alarm Function	54
4.6	Maintenance Parts/Optional Parts	55
4.6.1	Maintenance Parts	55
4.6.2	Optional Parts	56

4.6.3	Cutting the Tape Scale.....	56
4.7	External View and Dimensional Drawings	58
4.7.1	Specifications for Fixing at Both Ends (Effective Length of 500 mm–1000 mm)	58
4.7.2	Specifications for Fixing at Both Ends (Effective Length of 1100 mm–12000 mm) ...	60
4.7.3	Specifications for Fixing with Double-Sided Tape (Effective Length of 10 mm–3000 mm) 63	
4.7.4	Specifications for Fixing at the Center (Effective Length of 500 mm–2200 mm)	66
4.7.5	Specifications for Fixing at the Center (Effective Length of 2400 mm–4200 mm).....	68
4.7.6	Specifications for Fixing at the Center (Effective Length of 4400 mm–6000 mm) ...	70
5	Troubleshooting	73
	SERVICE NETWORK	App-1

1 Overview

This chapter describes the features of this product, the names and functions of the parts, and the flow of the main tasks to use this product.

1.1 Features

The ABS ST1300 Series is a reflective photoelectric linear encoder equipped with a two-sided telecentric imaging optical system. The two-sided telecentric imaging optical system captures a scale grid as an image and detects its travel distance using light receiving elements. With a focal depth deeper than the conventional optical system, this system has a greater allowance for changes in the gap, such as allowance for scale undulation, stage posture change, and Detector installation. It also secures a wide imaging range, resulting in a greater allowance even for dirt and small scratches on the scale.

This product achieves the maximum effective length of 12 m, maximum response speed of 8 m/s, and minimum resolution of 0.001 μm . In addition, the following interface specifications compatible with the high-speed serial interface of the companies are available:

- Mitsubishi Electric Corporation specifications
- FANUC Corporation specifications
- Panasonic Corporation specifications
- Yaskawa Electric Corporation specifications
- Mitutoyo Corporation ENSIS[®] specifications

1.2 System Configuration and Name of Each Part

The system configuration and the name of each part are shown below.

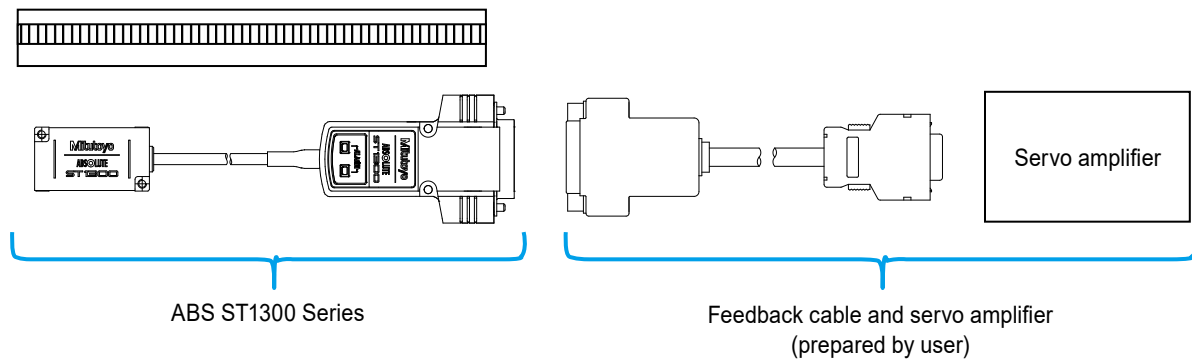

A feedback cable with the Yaskawa Electric specifications requires an optional ST1380A connection cable (P/N: 06AFA434A, 06AFA434B, or 06AFA434C).

1.2.1 Specifications for Fixing at Both Ends

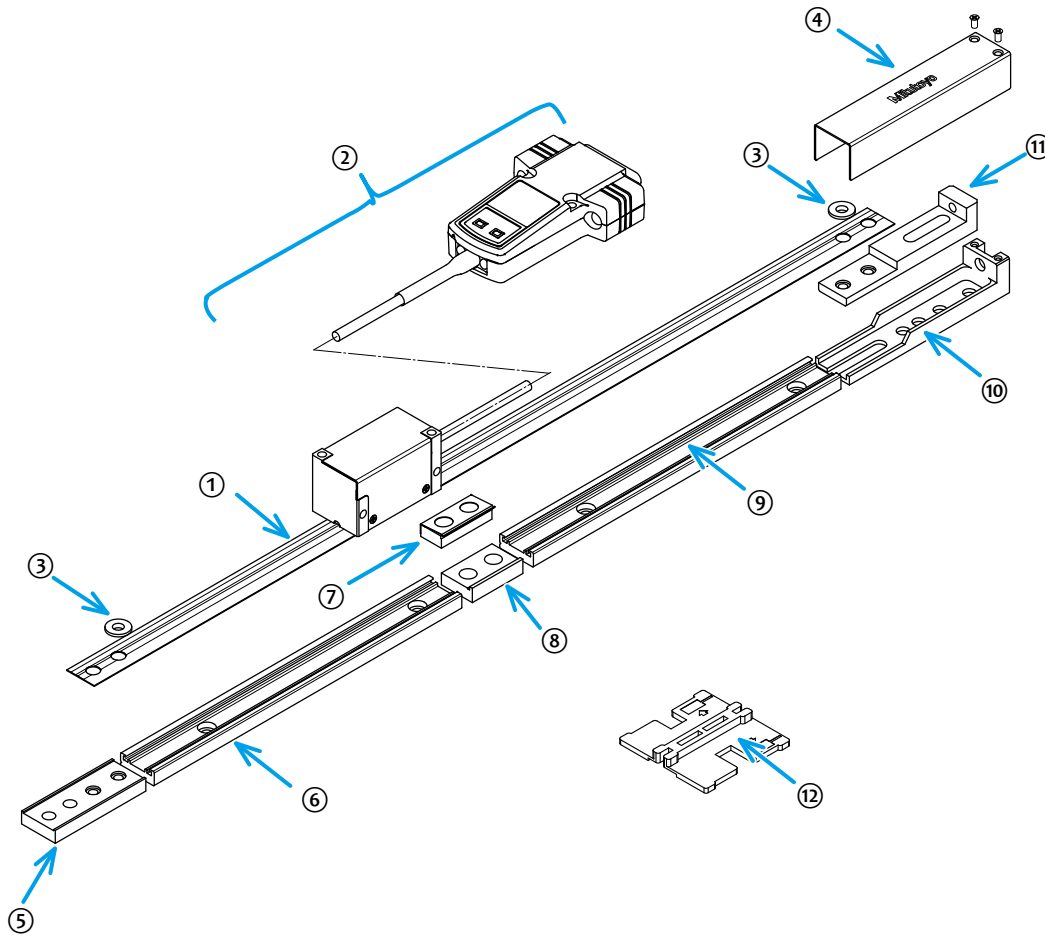

No.	Name
①	Tape scale
②	Detection unit
③	Sleeve washer
④	Cover
⑤	Fixing base
⑥	Scale holder B
⑦	Intermediate fixing spring Ass'y
⑧	Intermediate fixing base
⑨	Scale holder A
⑩	Pull block A
⑪	Pull block B
⑫	Mounting auxiliary tool (for fixing at both ends or fixing at the center)

1.2.2 Specifications for Fixing with Double-Sided Tape

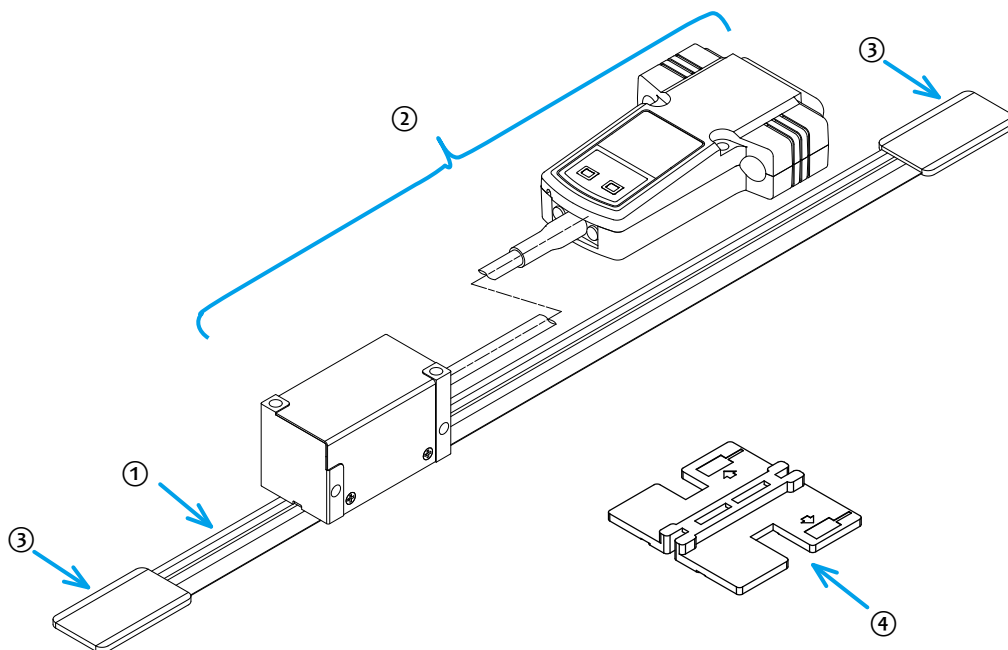

No.	Name
①	Tape scale
②	Detection unit
③	End cap
④	Mounting auxiliary tool (for fixing with double-sided tape)

1.2.3 Specifications for Fixing at the Center

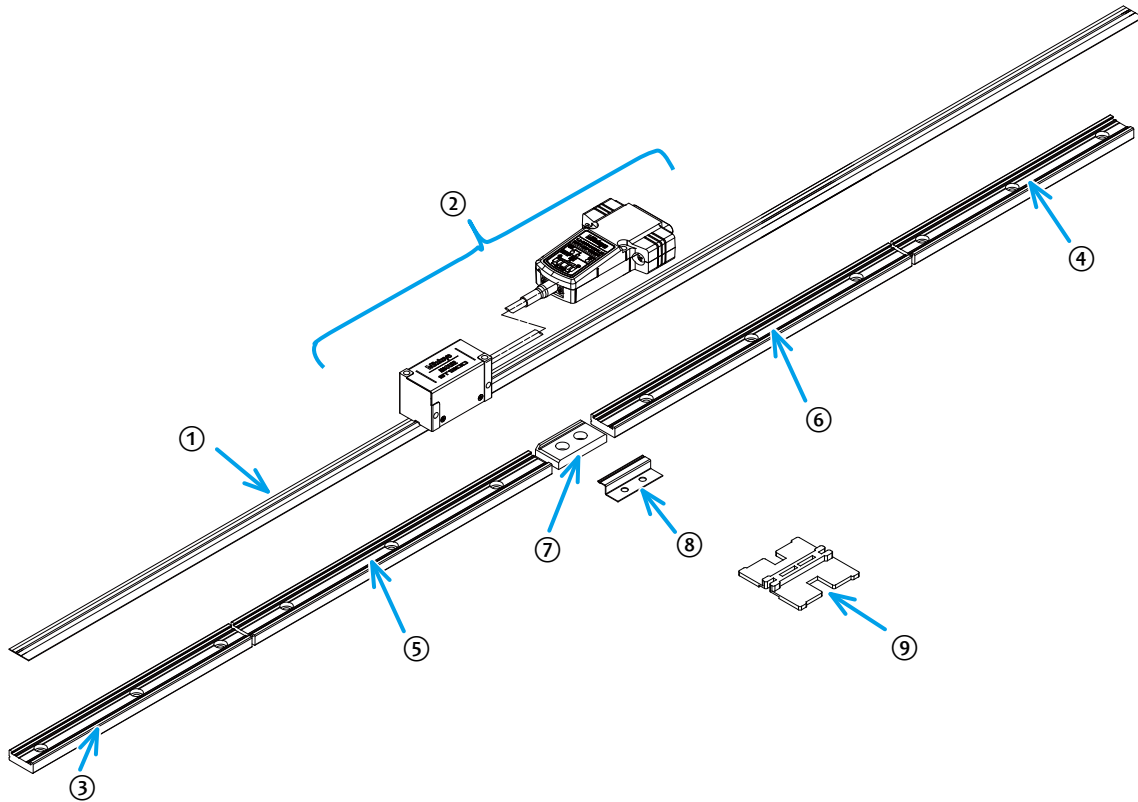

No.	Name
①	Tape scale
②	Detection unit
③	Scale holder C
④	Scale holder D
⑤	Scale holder E
⑥	Scale holder (998 mm)
⑦	Center fixing base
⑧	Intermediate fixing spring
⑨	Mounting auxiliary tool (for fixing at both ends or fixing at the center)

1.2.4 Detection Unit

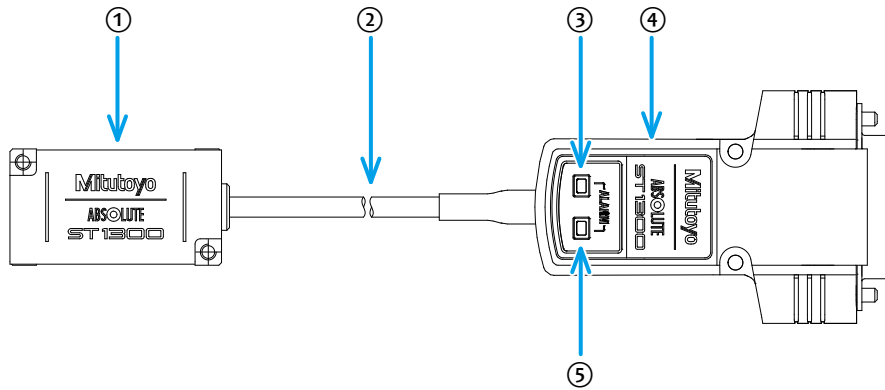

No.	Name
①	Detector
②	Detector cable
③	LED (yellow)
④	Electrical connector
⑤	LED (red)

Tips

You can check the following states by the electrical connector LED.

State	LED state
Power on	The LED (yellow) and LED (red) turn on for about 2 seconds at power-on and then turn off.
Caution	The LED (yellow) turns on when a caution occurs. When the cause is eliminated, the LED (yellow) turns off.
Error	The LED (red) turns on when an error occurs. The state will be maintained until the error is reset, or the power is re-supplied.

1.3 The Flow of Main Tasks

The following chart shows the flow of preliminary preparation and installation onto the machine main unit as tasks to use this product.

1.3.1 Preliminary Preparation

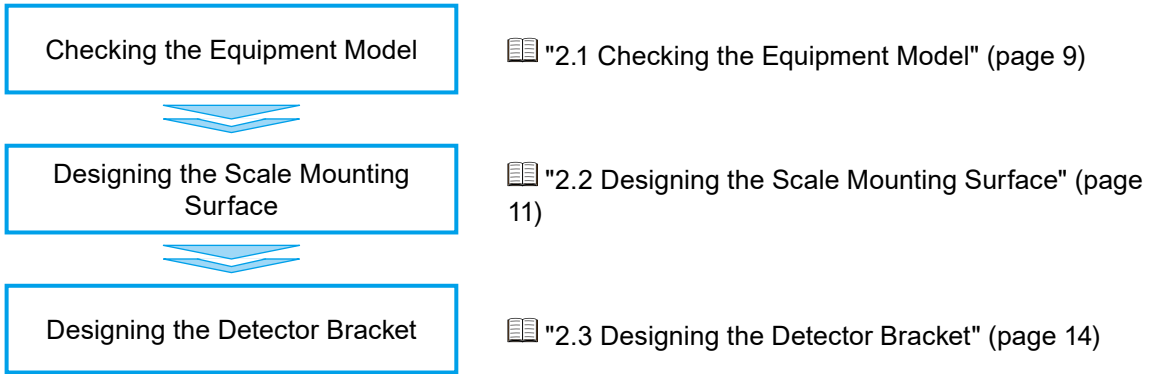

1.3.2 Installation onto the Machine Main Unit

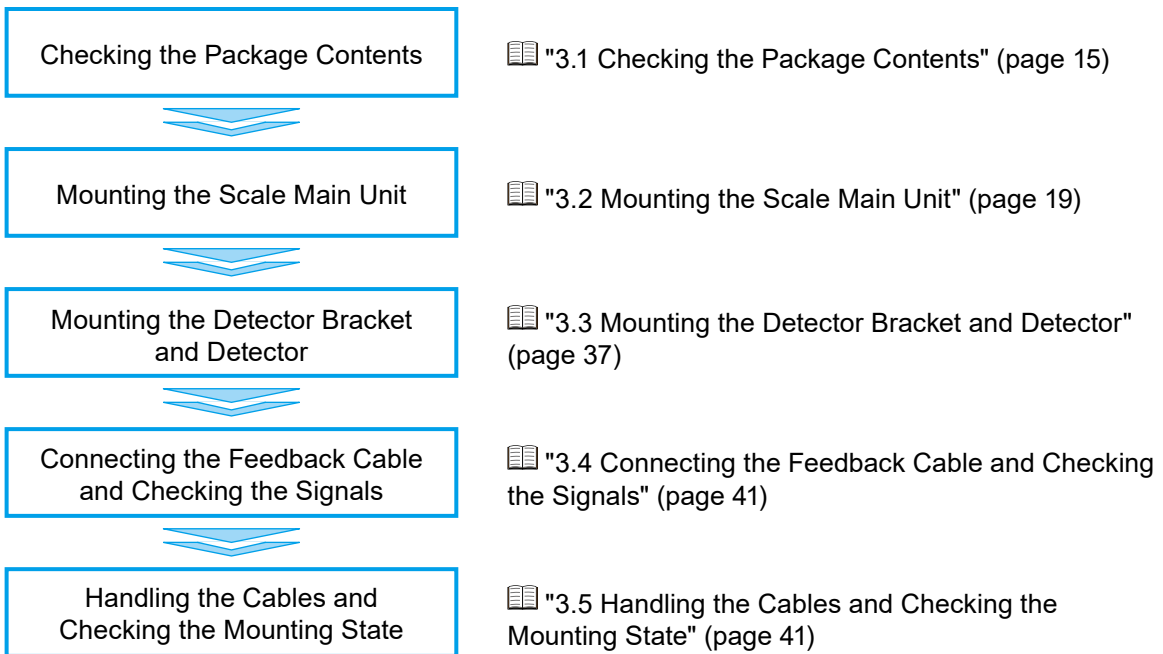



- After mounting the scale unit, check the Detector signals according to the instructions in "ABS ST1300 Series Signal Check Program User's Manual". For details, refer to "ABS ST1300 Series Signal Check Program User's Manual" (No. 99MBE085B).
- Use the tape scale and the Detector that have the same serial No. written on the attached sticker.
- To check the Detector signals after mounting the scale unit, you need a PC and peripheral equipment. Prepare the necessary equipment by referring to "1.3 Preparation" in "ABS ST1300 Series Signal Check Program User's Manual".

MEMO

2 Setup for Installation

This chapter describes the preliminary preparation for installing this product onto the machine main unit.

2.1 Checking the Equipment Model

The linear scale ABS ST1300 Series model number is determined based on the interface specifications, resolution, communication method, effective length, and scale mounting specifications.

Make sure that your linear scale model supports the servo amplifier to be used.

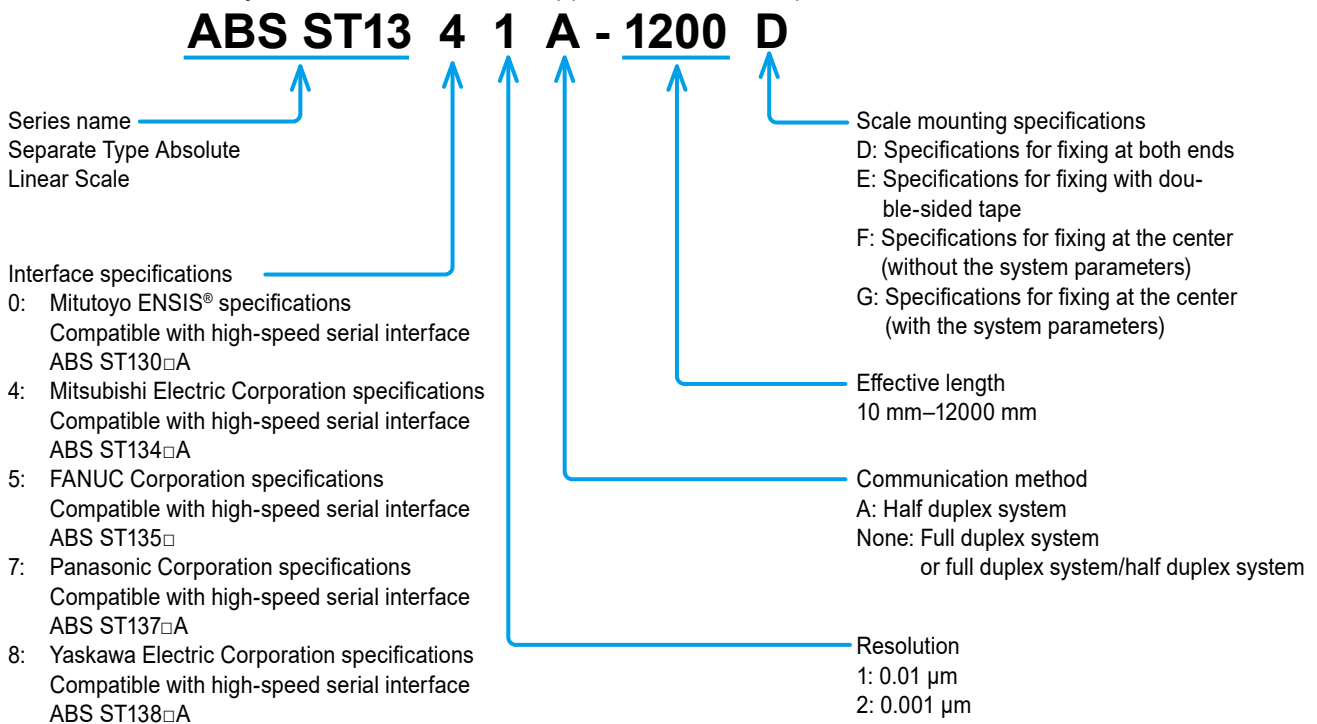

2.1.1 System Parameters

Some linear scale ABS ST1300 Series models use the system parameters (scale-specific parameters) to make use of the predetermined performance.

Whether the system parameters are available or not depends on the scale mounting specifications as follows.

Scale mounting specifications	System parameters	Indication accuracy (20 °C)
D: Specifications for fixing at both ends	Available	$\pm 5 \mu\text{m}$ (1 m or less) $\pm 5 \mu\text{m/m}$ (1.1 m or more)
E: Specifications for fixing with double-sided tape	Available	$\pm 5 \mu\text{m}$ (1 m or less) $\pm 5 \mu\text{m/m}$ (1.1 m or more)
F: Specifications for fixing at the center	Not available	$\pm 10 \mu\text{m}$ (1 m or less) $\pm 10 \mu\text{m/m}$ (1.1 m or more)
G: Specifications for fixing at the center	Available	$\pm 5 \mu\text{m}$ (1 m or less) $\pm 5 \mu\text{m/m}$ (1.1 m or more)

For the scale mounting specifications D, E, and G, you can use the factory default set of scale and Detector as the system parameters are already written into the Detector before shipment. However, if the Detector fails or another Detector is added later (such as when two or more Detectors are used in one scale), the system parameters corresponding to the scale must be written into the new Detector.

For any questions about the system parameters, please contact your dealer or the nearest Mitutoyo sales office/service center.



- Contact Mitutoyo for the cases below:
 - The Detector in use fails.
 - A Detector needs to be stocked up as a backup for failure.
 - A Detector needs to be added later.
- If the scale in use fails, both the scale and Detector need to be replaced.

2.2 Designing the Scale Mounting Surface

2.2.1 Mounting the Scale with the Specifications for Fixing at Both Ends

Design the scale mounting area as shown in the figure below according to "4.7.1 Specifications for Fixing at Both Ends (Effective Length of 500 mm–1000 mm)" (page 58) and "4.7.2 Specifications for Fixing at Both Ends (Effective Length of 1100 mm–12000 mm)" (page 60).

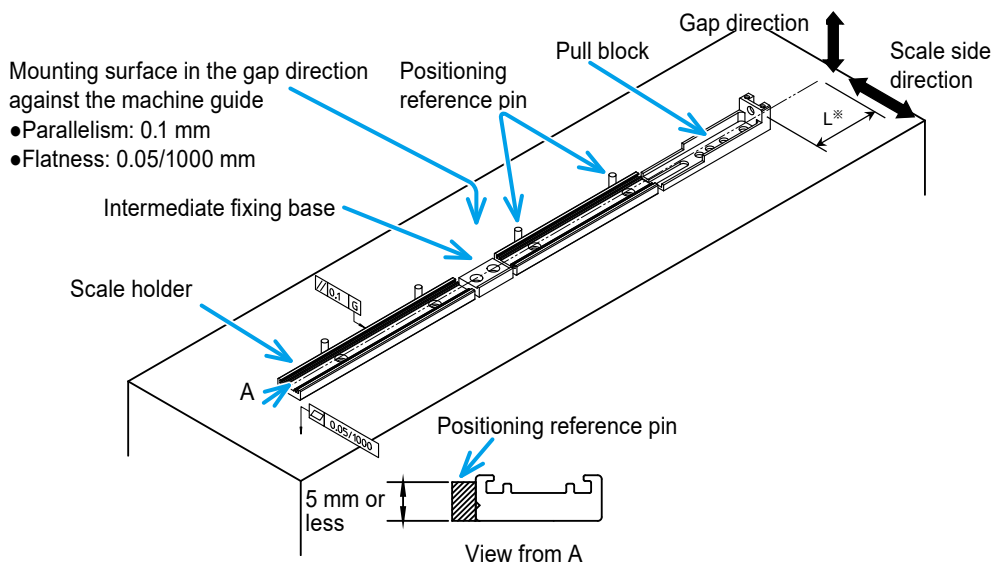

- L must be about 200 mm in size to secure a working space for fixing pull blocks and tightening pull screws.
- Design it so that the scale can be mounted with the parallelism in the scale side direction against the machine guide set to 0.1 mm. The scale holder surface with a groove on its side is the mounting reference surface in the scale side direction.
- For the scale with the effective length of 1100 mm–12000 mm, which comes with the intermediate fixing base, set the pin hole position in a location where the positioning reference pin does not come in contact with the intermediate fixing base.
- Set the positioning reference pin according to the pitch of the scale holder fixing screw.
- The abutting of the scale holder can be also set with stepped machining. Even in this case, secure the above specified value for the parallelism against the machine guide.

2.2.2 Mounting the Scale with the Specifications with Double-Sided Tape

Design the scale mounting area as shown in the figure below according to  "4.7.3 Specifications for Fixing with Double-Sided Tape (Effective Length of 10 mm–3000 mm)" (page 63).

- Mounting surface in the gap direction
against the machine guide
- Parallelism: 0.1 mm
 - Flatness: 0.05/1000 mm

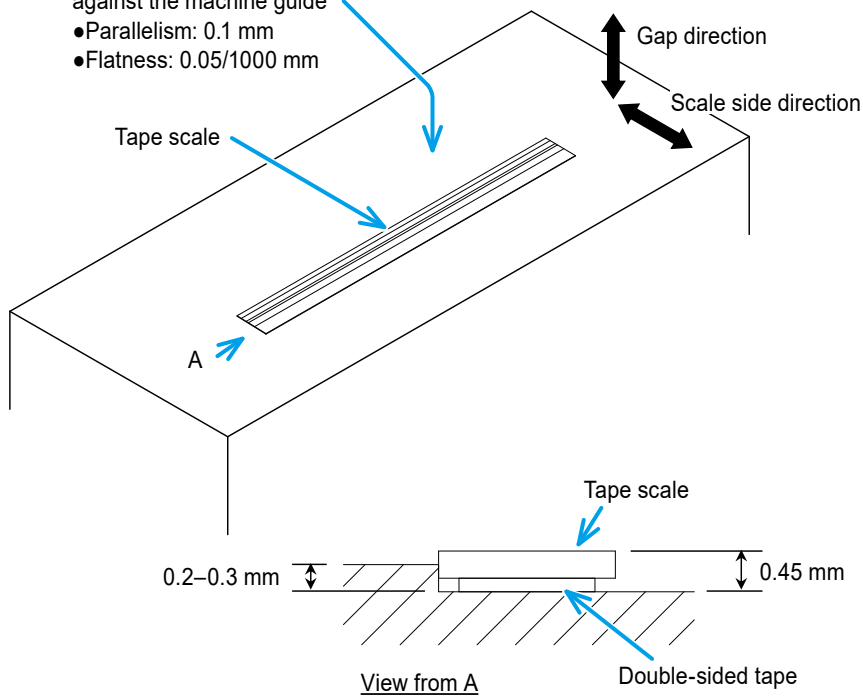

Design it so that the scale can be mounted with the parallelism in the scale side direction against the machine guide set to 0.1 mm.

Tips

Using the optional scale attaching auxiliary tool (P/N: 06AEQ305) makes it easier to mount the tape scale. For details, refer to  "Effective length of 200 mm–3000 mm" (page 29).

2.2.3 Mounting the Scale with the Specifications for Fixing at the Center

Design the scale mounting area as shown in the figure below according to "4.7.4 Specifications for Fixing at the Center (Effective Length of 500 mm–2200 mm)" (page 66), "4.7.5 Specifications for Fixing at the Center (Effective Length of 2400 mm–4200 mm)" (page 68), and "4.7.6 Specifications for Fixing at the Center (Effective Length of 4400 mm–6000 mm)" (page 70).

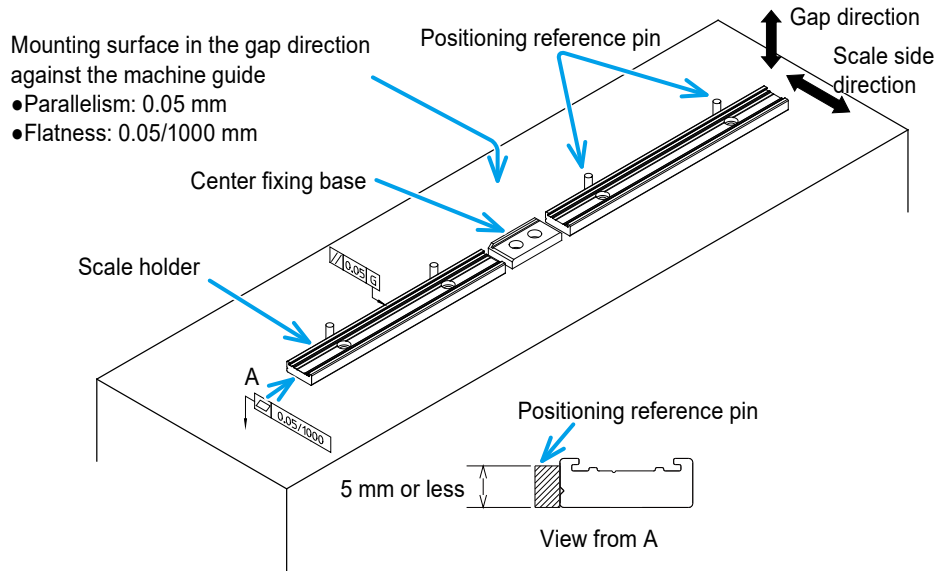

- Design it so that the scale can be mounted with the parallelism in the scale side direction against the machine guide set to 0.05 mm. The scale holder surface with a groove on its side is the mounting reference surface in the scale side direction.
- Set the pin hole position in a location where the positioning reference pin does not come in contact with the center fixing base.
- Set the positioning reference pin according to the pitch of the scale holder fixing screw.
- The abutting of the scale holder can be also set with stepped machining. Even in this case, secure the above specified value for the parallelism against the machine guide.

2.3 Designing the Detector Bracket

Design the Detector bracket according to the figure below. Its shape must allow adjustment of the Detector position (moire/gap). It is recommended that the Detector fixing screw holes should be long holes to make it easier to adjust the Detector position.

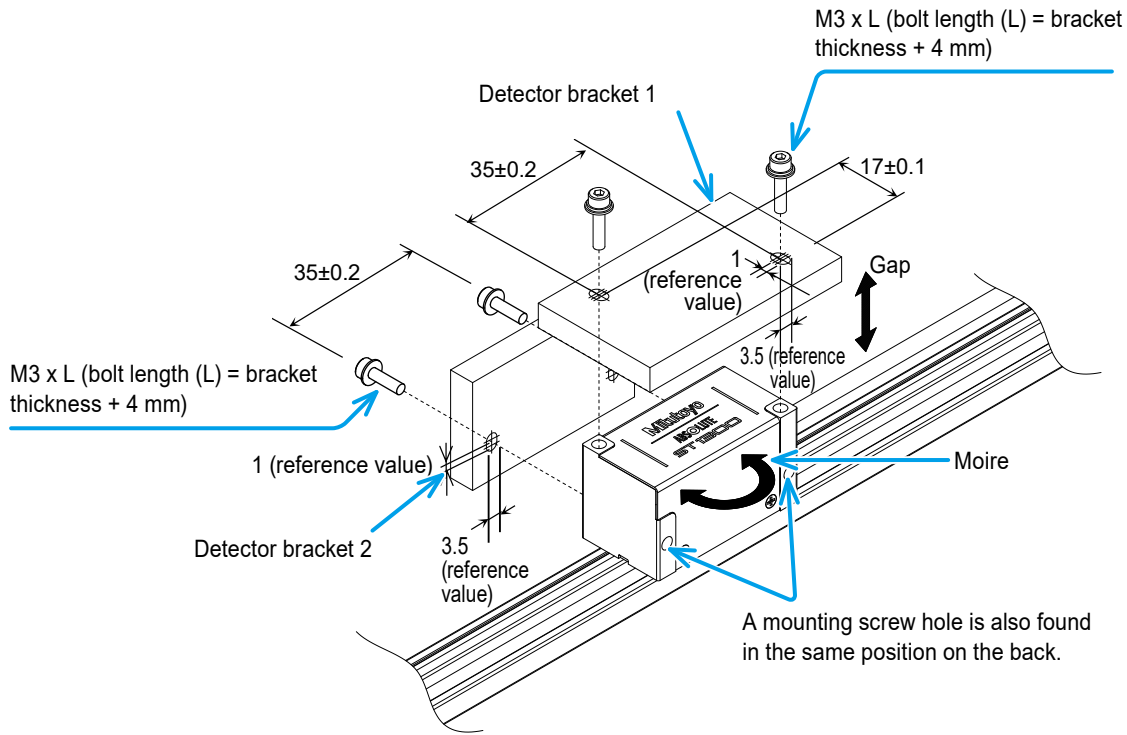

- Design it so that the parallelism of the Detector mounting surface against the scale mounting surface is within 0.05 mm.
- The change in the gap direction of the Detector within the maximum travel range of the machine unit must be within 0.05 mm.

Tips

If the thickness of the Detector mounting bracket is insufficient, the rigidity of the bracket may decrease, which also lowers the rigidity of the servo mechanism. Take this into consideration when determining the thickness of the bracket.

3 Installation onto the Machine Main Unit



This chapter describes the procedures, methods, and precautions required when mounting this product onto the machine main unit.

3.1 Checking the Package Contents

Before installation, make sure that the product package contains the following items.

If your scale does not satisfy the specified specifications or you have any questions or concerns about the product, please contact your dealer or the nearest Mitutoyo sales office/service center.

3.1.1 Specifications for Fixing at Both Ends

Name	Quantity	Note
Tape scale	1	Check the effective length.
Detection unit	1	
Scale holder A	1	
Scale holder B		This accessory comes with the scale with the effective length of 1100 mm or more. For details on the quantity, refer to  "4.7.2 Specifications for Fixing at Both Ends (Effective Length of 1100 mm–12000 mm)" (page 60).
Pull block A	1	
Pull block B	1	
Fixing base	1	
Sleeve washer	2	
Intermediate fixing base		This accessory comes with the scale with the effective length of 1100 mm or more. For details on the quantity, refer to  "4.7.2 Specifications for Fixing at Both Ends (Effective Length of 1100 mm–12000 mm)" (page 60).
Intermediate fixing spring Ass'y		This accessory comes with the scale with the effective length of 1100 mm or more. For details on the quantity, refer to  "4.7.2 Specifications for Fixing at Both Ends (Effective Length of 1100 mm–12000 mm)" (page 60).
Cover	1	
Countersunk screw (M2 x 4)	2	
Mounting auxiliary tool (for fixing at both ends or fixing at the center)	1	
User's Manual	1	This document
Warranty card	1	
Inspection certificate	1	

3 Installation onto the Machine Main Unit



To mount the scale unit, prepare the following parts.

Part name	Quantity	Note
Hex socket head cap screw (M3 x 6)	16–165	For fixing the scale holder, intermediate fixing base, and intermediate fixing spring Ass'y. For details on the required quantity, refer to "4.7.1 Specifications for Fixing at Both Ends (Effective Length of 500 mm–1000 mm)" (page 58) and "4.7.2 Specifications for Fixing at Both Ends (Effective Length of 1100 mm–12000 mm)" (page 60).
Hex socket head cap screw (M4 x 5)	4	For fixing the tape scale
Hex socket head cap screw (M4 x 8)	2	For fixing the pull block A
Hex socket head cap screw (M4 x 10)	2	For fixing the fixing base
Hex socket head cap screw (M4 x 14)	2	For fixing the pull block B
Hex socket head cap screw (M4 x 16)	1	Screw for pulling the tape scale
Hex socket head cap screw (M3 x L)	2	For mounting the Detector. Determine the screw length based on the thickness of the prepared Detector bracket and the depth of the Detector screw hole.
Plain washer (polished round, nominal diameter 4)	4	For fixing the tape scale and pull block B
Plain washer (nominal diameter 3)	2	For fixing the Detector
Spring washer (nominal diameter 3)	2	For fixing the Detector

3.1.2 Specifications for Fixing with Double-Sided Tape

Name	Quantity	Note
Tape scale	1	Check the effective length.
Detection unit	1	
End cap	2	
Mounting auxiliary tool (for fixing with double-sided tape)	1	
User's Manual	1	This document
Warranty card	1	
Inspection certificate	1	

3 Installation onto the Machine Main Unit



- To mount the scale unit, prepare the following parts.

Part name	Quantity	Note
Hex socket head cap screw (M3 x L)	2	For mounting the Detector. Determine the screw length based on the thickness of the prepared Detector bracket and the depth of the Detector screw hole.
Plain washer (nominal diameter 3)	2	For fixing the Detector
Spring washer (nominal diameter 3)	2	For fixing the Detector
Roller	1	Option (P/N: 06AEJ505)

- To mount the tape scale with the effective length of 200 mm–3000 mm, prepare the following parts.

Part name	Quantity	Note
Scale attaching auxiliary tool	1	Option (P/N: 06AEQ305)

3.1.3 Specifications for Fixing at the Center

Name	Quantity	Note
Tape scale	1	Check the effective length.
Detection unit	1	
Scale holder C	1	
Scale holder D	1	
Scale holder E		One holder comes with the scale with the effective length of 2400 mm or more.
Scale holder (998 mm)		One holder comes with the scale with the effective length of 2400 mm–4200 mm, and three holders come with the scale with the effective length of 4400 mm–6000 mm.
Center fixing base	1	
Center fixing spring	1	
Mounting auxiliary tool (for fixing at both ends or fixing at the center)	1	
User's Manual	1	This document
Warranty card	1	
Inspection certificate	1	

3 Installation onto the Machine Main Unit



To mount the scale unit, prepare the following parts.

Part name	Quantity	Note
Hex socket head cap screw (M3 x 6)	10–70	For details on the quantity required to fix the scale holders, refer to  "4.7.4 Specifications for Fixing at the Center (Effective Length of 500 mm–2200 mm)" (page 66), "4.7.5 Specifications for Fixing at the Center (Effective Length of 2400 mm–4200 mm)" (page 68), and "4.7.6 Specifications for Fixing at the Center (Effective Length of 4400 mm–6000 mm)" (page 70).
Plain washer (small round, nominal diameter 3)	2	For fixing the center fixing spring

3.2 Mounting the Scale Main Unit

NOTICE

Be very careful that the tape scale is not damaged or broken.



If dirt and dust are attached to the tape scale, it causes a malfunction or deteriorates the accuracy. Wipe off the dirt and dust with a soft cloth soaked in ethanol or cleaning paper. Similarly, clean the tape scale mounting surface of the machine unit thoroughly with ethanol. Even for parts that come in contact with the tape scale, such as scale holders, clean them fully with ethanol.

Tips

- Conduct temperature leveling thoroughly for both the tape scale and mounting parts before fixing them. The accuracy of this product is guaranteed at 20 °C. The recommended temperature leveling is about 8 hours or longer at 20 °C for both the tape scale and parts for mounting the scale. Perform installation after temperature leveling.
- If the temperature environment is insufficient, including temperature leveling, the predetermined indication accuracy may not be achieved.
- To prevent any differences in temperature between the tape scale and the machine unit resulting from heat from the hands, wear gloves during installation.
- Please note that wiping the tape scale with ethanol after temperature leveling drops the temperature of the wiped area.

3.2.1 Specifications for Fixing at Both Ends

- 1 Fix the scale holder A and pull block A.

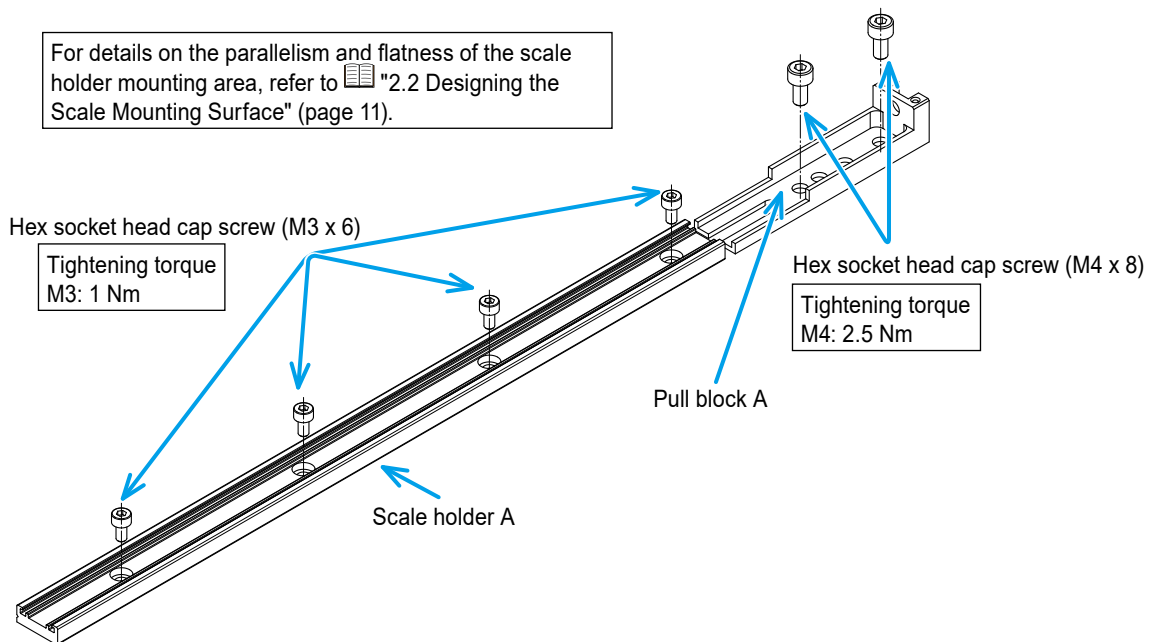

3 Installation onto the Machine Main Unit



For the scale with the effective length of 1100 mm or more, fix as many scale holder B units and intermediate fixing base units as supplied.

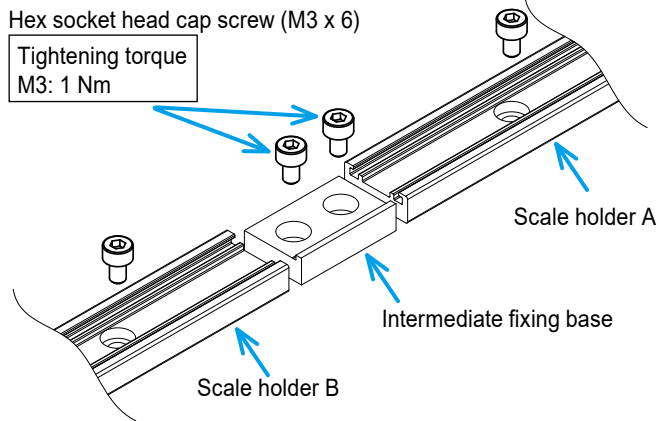

2 Peel the scale protection tape.

Tips

Wipe the tape scale thoroughly with a soft cloth soaked in ethanol or cleaning paper.

3 Insert the tape scale into the scale holder.

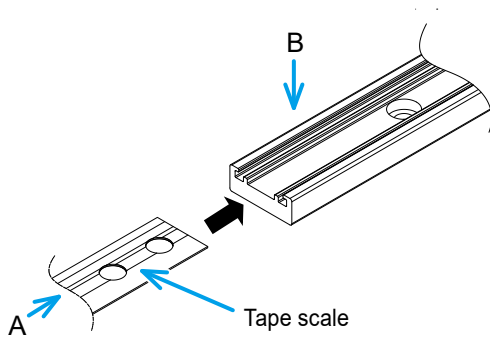

Make sure that the tape scale is inserted into the scale holder in the correct scale pattern direction.

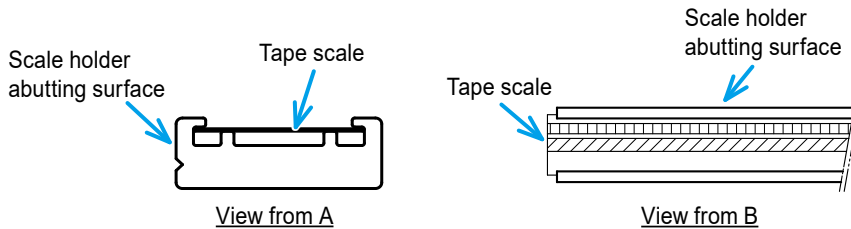

3 Installation onto the Machine Main Unit

- 4** Put the pull block B on the pull block A and temporarily fix it.

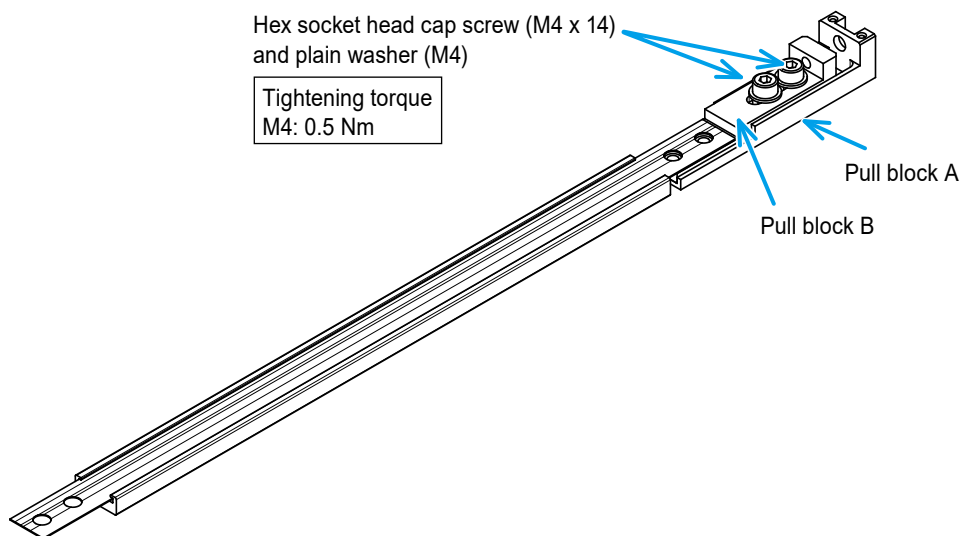

- 5** Fix the fixing base.

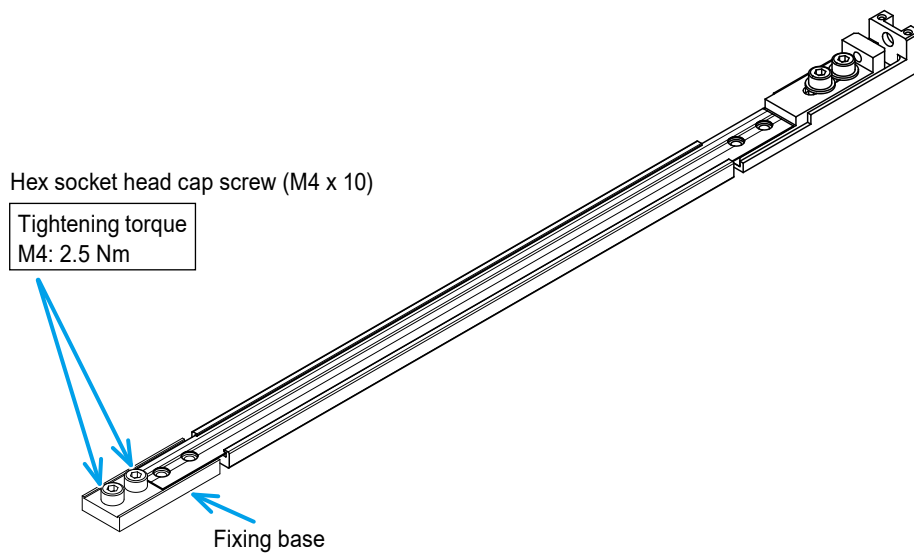

3 Installation onto the Machine Main Unit

6 Temporarily fix the tape scale at both ends with the sleeve washers.

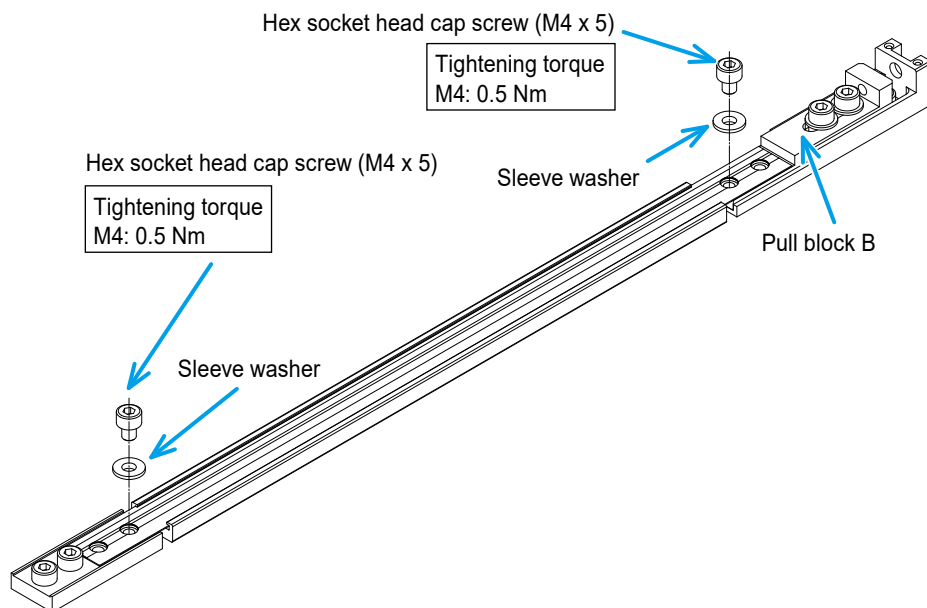

- Be sure to use the supplied sleeve washers.
- Make sure that the sleeve washers and hex socket head cap screws are installed into the inside holes at both ends of the tape scale.
- The convex part of each sleeve washer must be put in the bolt hole on the tape scale.

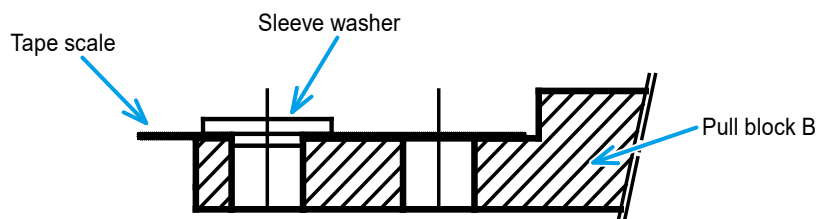

3 Installation onto the Machine Main Unit

- 7** Pull the tape scale up to the specified amount with the pull block B.
 - 1** Mount the Detector by referring to  "3.3 Mounting the Detector Bracket and Detector" (page 37).
 - 2** Be prepared to check the Detector signals according to the instructions in "ABS ST1300 Series Signal Check Program User's Manual".
 - 3** Install the hex socket head cap screw (M4 x 16) on the pull block B.

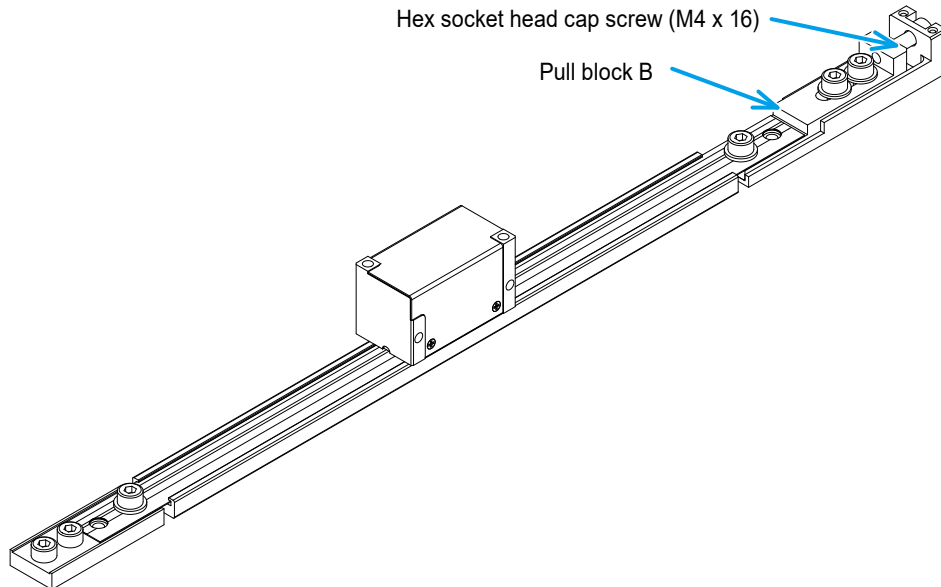

- 4** Display the Position Monitor screen according to the instructions in "3.4 Checking the Position Data" in "ABS ST1300 Series Signal Check Program User's Manual".

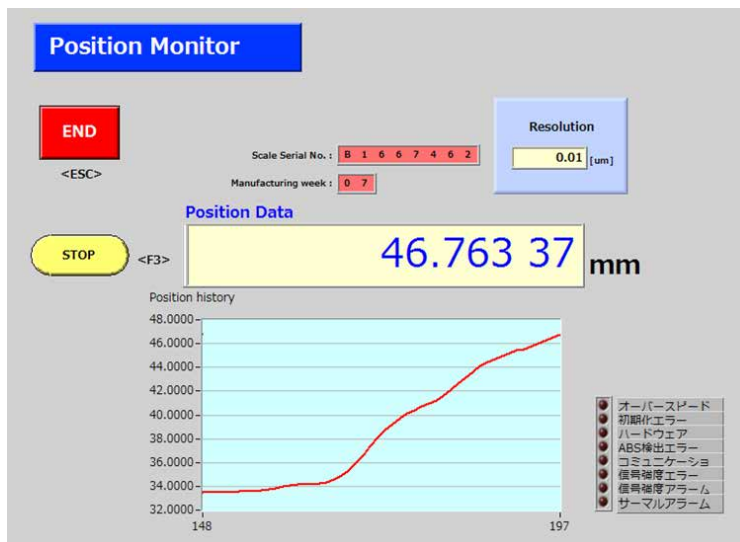

3 Installation onto the Machine Main Unit

- 5 While checking [Position Data] on the Position Monitor screen, move the Detector to an appropriate position.

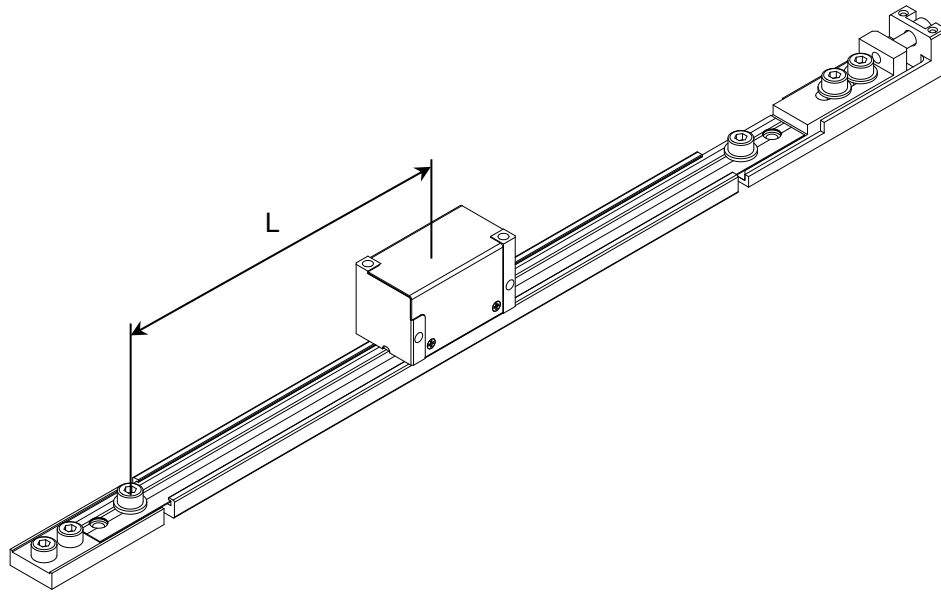

Tips

Move the Detector to a position where the pulling amount of the tape scale can be easily calculated such as 1000 mm.

- 6 Turn the hex socket head cap screw (M4 x 16) installed on the pull block B. Then, while checking [Position Data] on the Position Monitor screen, pull the tape scale.

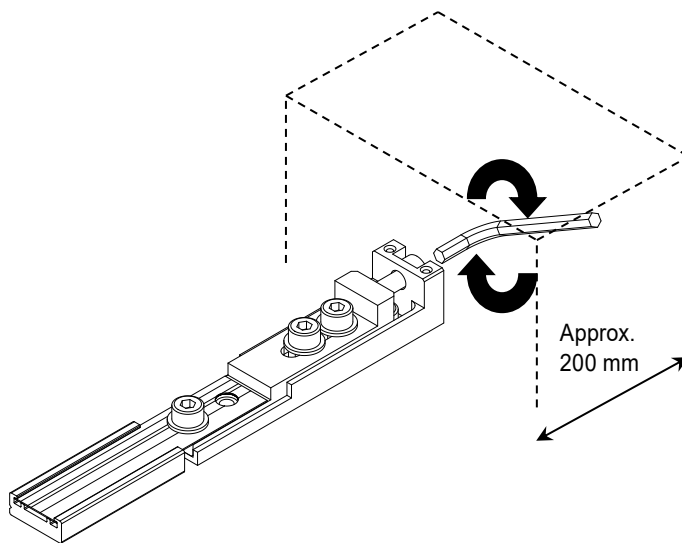

Pull the tape scale until the [Position Data] value reaches the amount calculated by the following formula:

$$[\text{Position Data}] \text{ value} = \text{Detector position (L)} - \text{Detector position (L)} \times 0.00025$$

For example, when the Detector position is 1000 mm, pull the tape scale until the [Position Data] value reaches the following amount:

$$[\text{Position Data}] \text{ value} = 1000 - 1000 \times 0.00025 = 999.75$$

- 8 Install the plain washers (M4) and hex socket head cap screws (M4 x 5) into the outside holes at both ends of the tape scale.

3 Installation onto the Machine Main Unit

- 9** Fully tighten the bolts at both ends of the tape scale.

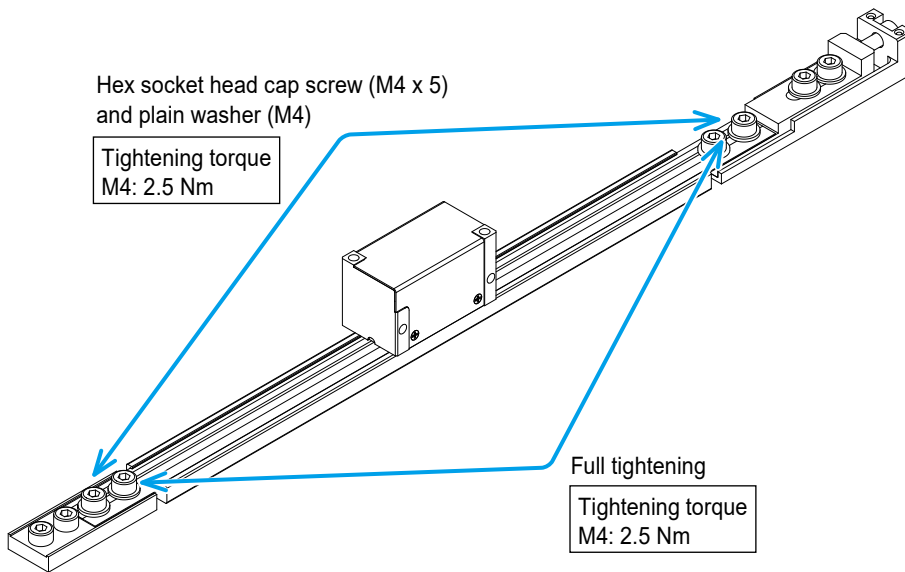

Do not move the Detector when fixing at both ends of the tape scale.

- 10** Loosen the hex socket head cap screws (M4 x 16) to release the pull block B's tension (pulling force) to the tape scale.
- 11** On the Position Monitor screen of the Signal Check Program, make sure that the Detector position (pulling amount) has not changed.



If the Detector position (pulling amount) has changed, turn the hex socket head cap screws (M4 x 16) to pull the tape scale up to the calculated pulling amount.

- 12** Fully tighten the pull block B.

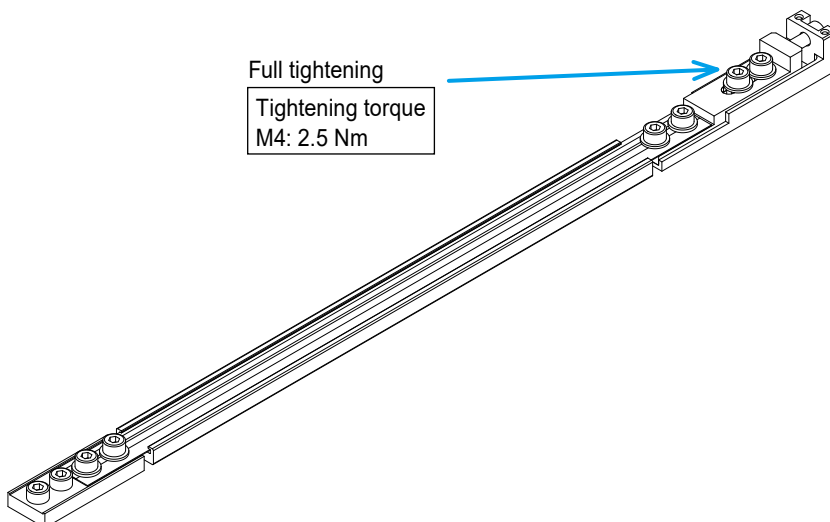

3 Installation onto the Machine Main Unit

13 Put the cover.

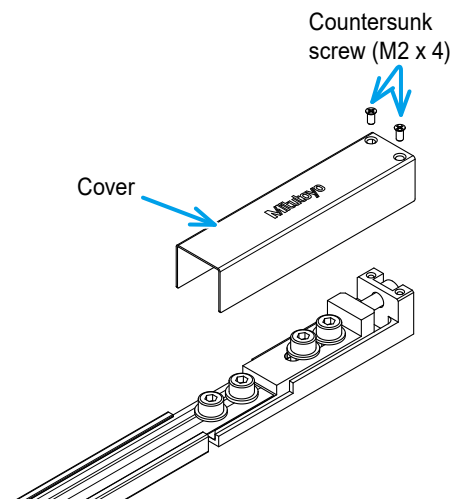

14 Mount the intermediate fixing spring Ass'y on the intermediate fixing base and fix it.

Hex socket head cap screw (M3 x 6)

Tightening torque
M3: 1 Nm

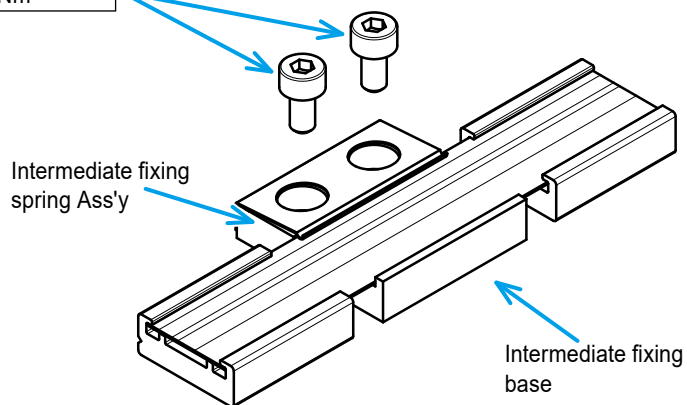

The intermediate fixing spring Ass'y is used for the scale with the effective length of 1100 mm or more.

3.2.2 Specifications for Fixing with Double-Sided Tape

■ Effective length of 10 mm–150 mm

- 1 Mark with a felt pen to the side of the tape scale attaching position and end cap fixing position.

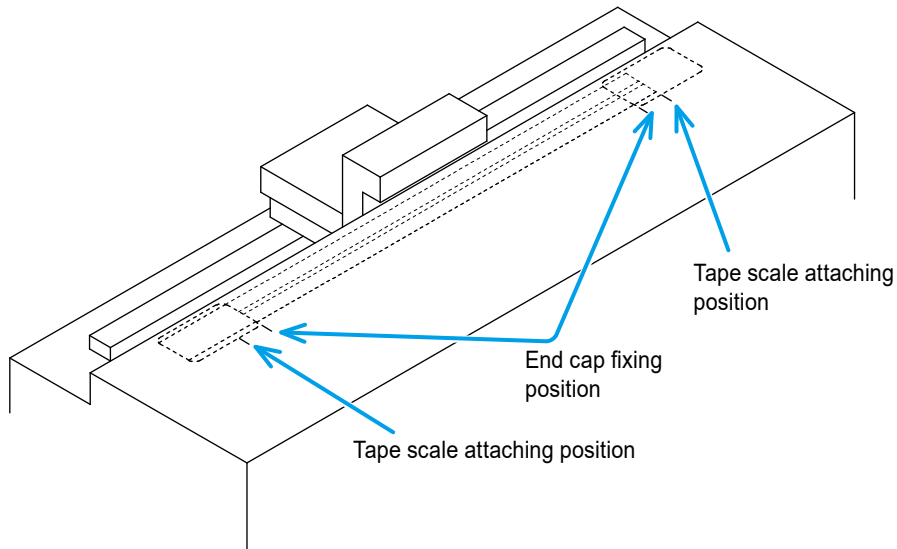

Tips

The end cap fixing position must be 10 mm inside the tape scale attaching position.

- 2 Peel the release paper of the double-sided tape on the tape scale.

Tips

Do not touch the adhesive surface of the double-sided tape.

- 3 Attach the tape scale.

3 Installation onto the Machine Main Unit

Tips

If you use a reference pin to attach the tape scale, make sure that it does not interfere with the Detector.

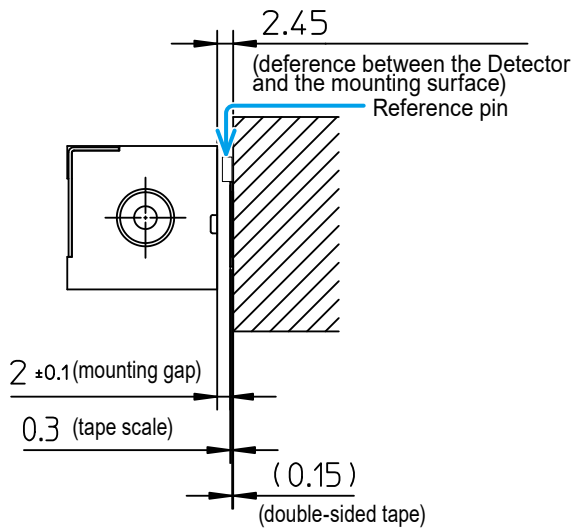

- 4 Press the roller on the top surface of the tape scale to level the adhesive surface against the machine unit.

The parallelism in the scale side direction against the machine guide must be within the following value:

- Parallelism: 0.1mm

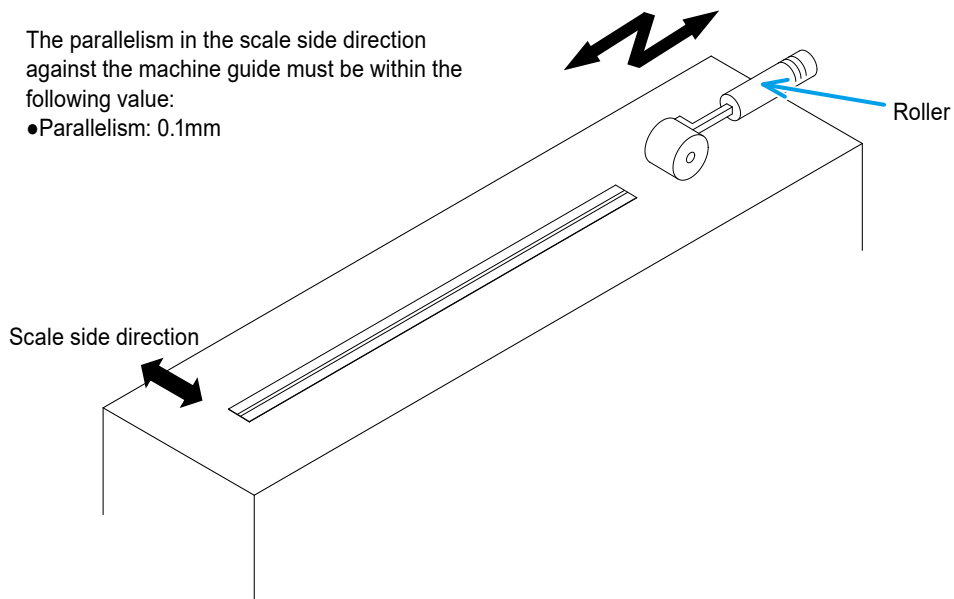

Tips

Apply a gentle force on the roller first and then gradually increase it so that the tape scale is attached evenly.

- 5 Peel the protection tape on the front of the tape scale.

3 Installation onto the Machine Main Unit

- 6 Peel the release paper of the tape on the back of each end cap and attach the end cap while aligning with the marked end cap fixing position.

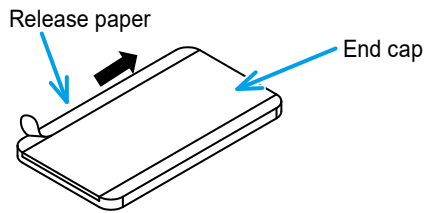

Tips

Attach the end caps to the end cap fixing position at both ends of the tape scale while aligning the concave part with the tape scale.

Effective length of 200 mm–3000 mm

Tips

To attach the tape scale with the specifications for fixing with double-sided tape with the effective length of 200 mm–3000 mm, it is recommended that the optional scale attaching auxiliary tool (P/N: 06AEQ305) should be used.

- 1 Mark with a felt pen to the side of the tape scale attaching position and end cap fixing position.

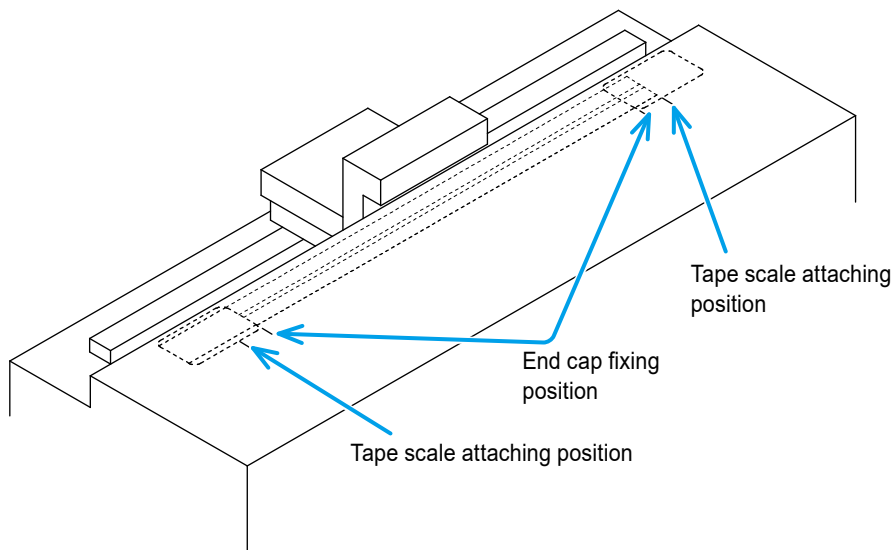

Tips

The end cap position must be 10 mm inside the tape scale attaching position.

3 Installation onto the Machine Main Unit

2 Mount the scale attaching auxiliary tool on the Detector bracket.

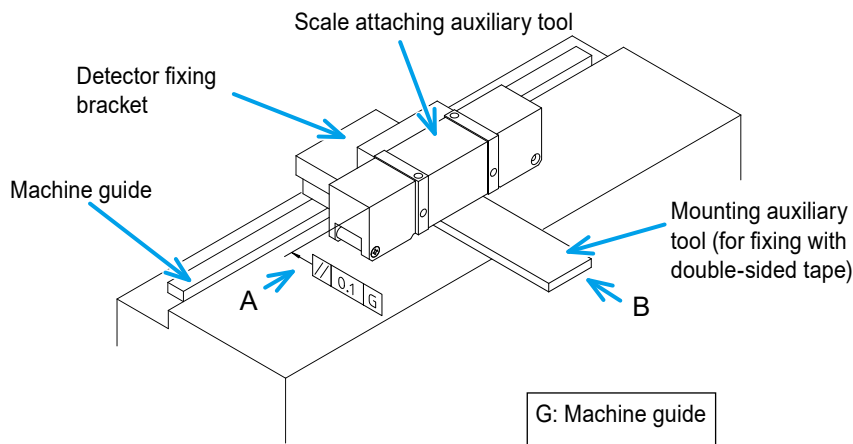

Use the mounting auxiliary tool (for double-sided tape) so that the gap between the scale attaching auxiliary tool and the tape scale mounting surface is 2.5 ± 0.1 mm.

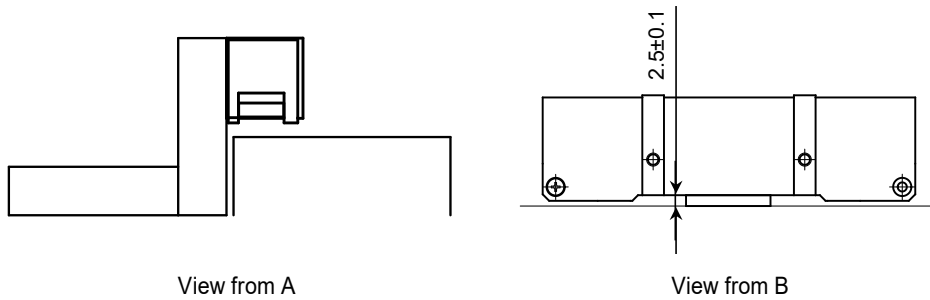

3 Put the tape scale in between the scale attaching auxiliary tool and the roller.

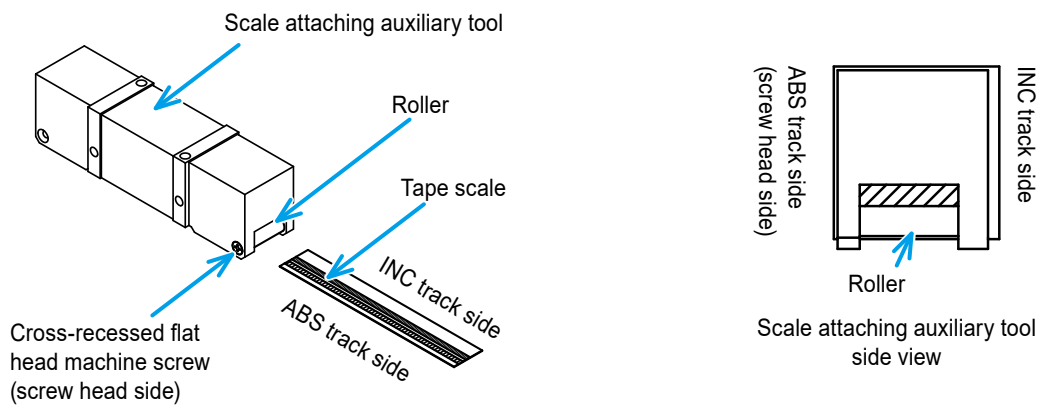

3 Installation onto the Machine Main Unit



Put the tape scale in so that the ABS track of the tape scale is on the head side of the cross-recessed flat head machine screw.

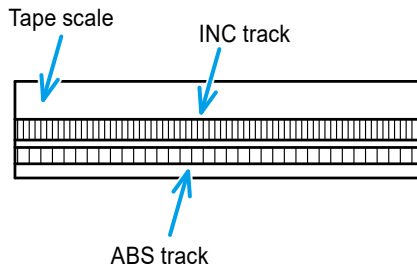

Tips

In this example, the tape scale is attached from the left-handed side using the scale attaching auxiliary tool. To attach it from the right-handed side, change the roller position of the scale attaching auxiliary tool.

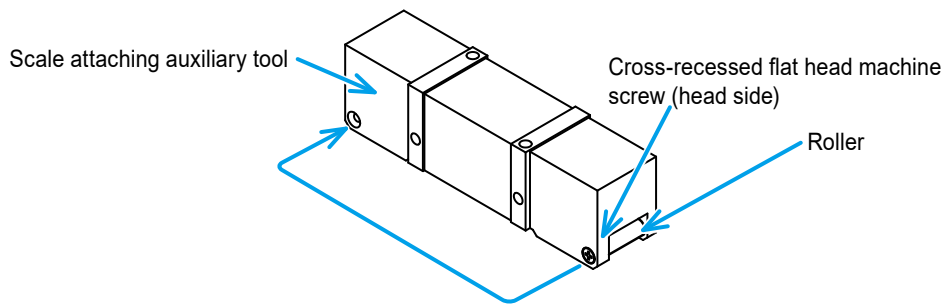

4 Pull out the tape scale by about 50 mm.

5 Peel the release paper of the tape on the tape scale by about 5 mm.

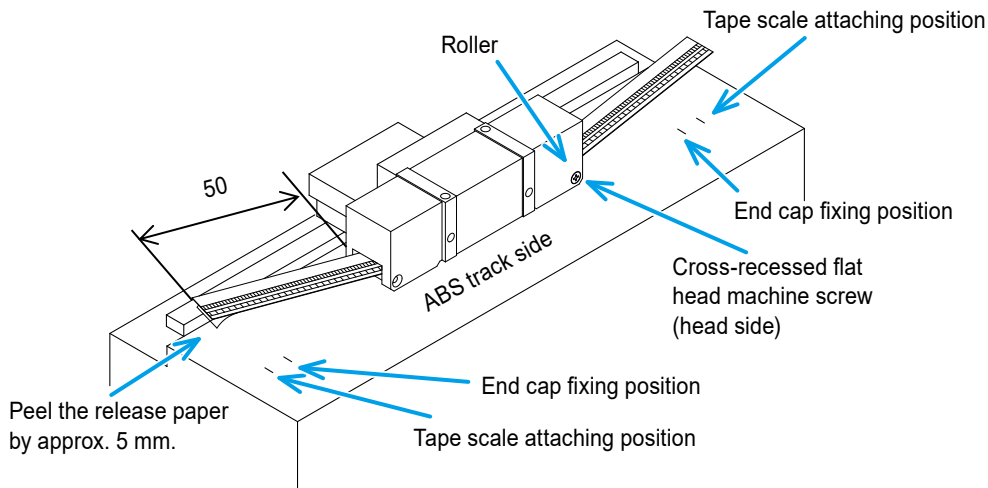

6 Attach the tape scale while aligning both ends with the marked scale attaching position.

Tips

Do not touch the adhesive surface of the double-sided tape.

3 Installation onto the Machine Main Unit

- 7** Peel the release paper of the tape and fold it to the roller of the scale attaching auxiliary tool.

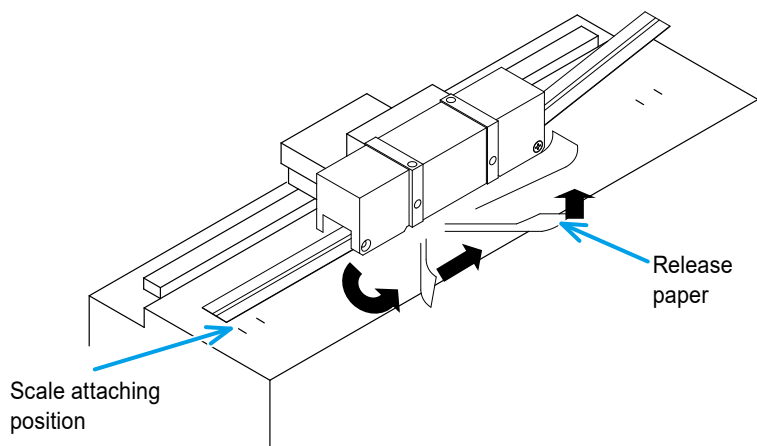

Tips

If you pull the release paper forcibly, it may be torn in the middle.

- 8** Attach the tape scale by moving the scale attaching auxiliary tool while peeling the release paper.

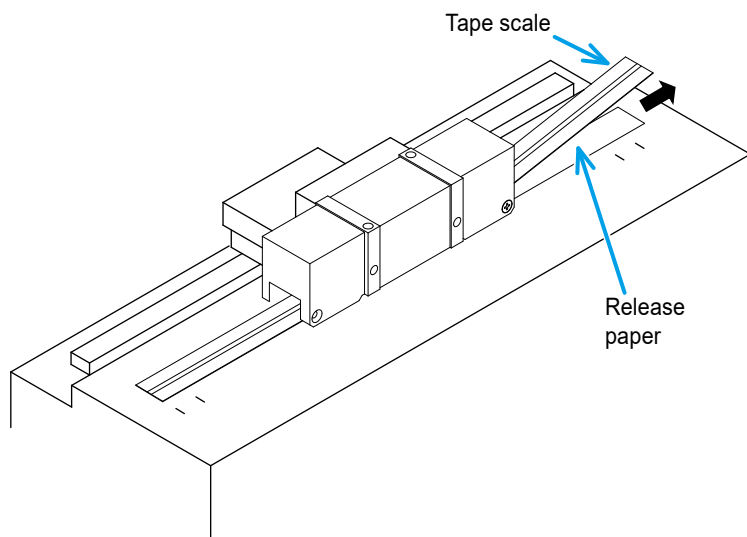

3 Installation onto the Machine Main Unit

Tips

- The release paper must be peeled by hand, parallel to the tape scale. If you pull the release paper diagonally or forcibly, it may be torn in the middle.
- If the travel range of the machine guide is shorter than the tape scale full length, you cannot attach the tape scale by moving the scale attaching auxiliary tool to the end of the tape scale. In such a cause, remove the roller of the scale attaching auxiliary tool before attaching the tape scale.

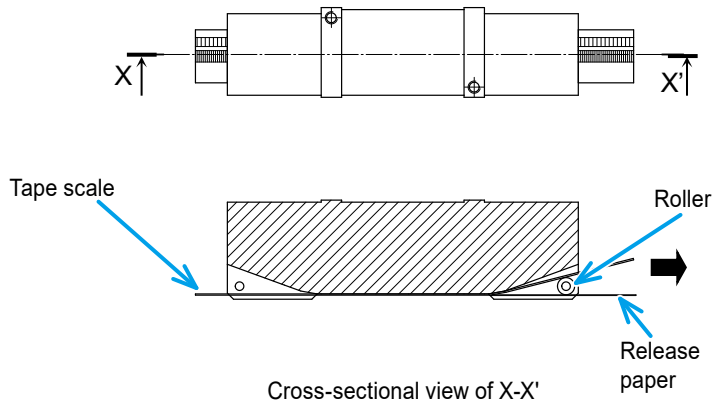

- 9** Press the roller on the top surface of the tape scale to level the adhesive surface against the machine unit.

The parallelism in the scale side direction against the machine guide must be within the following value:

- Parallelism: 0.1 mm

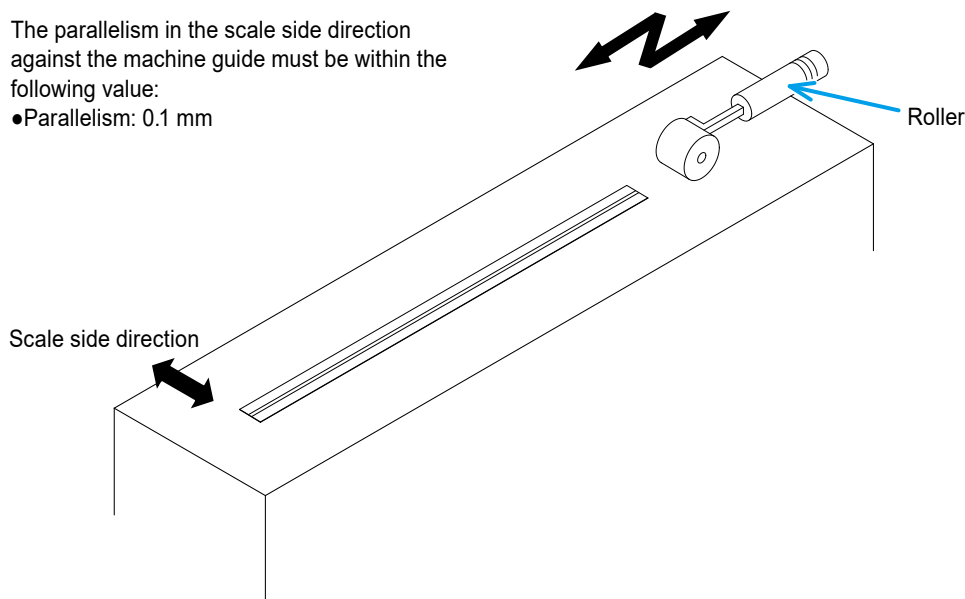

Tips

Apply a gentle force on the roller first and then gradually increase it so that the tape scale is attached evenly.

- 10** Peel the protection tape on the front of the tape scale.

3 Installation onto the Machine Main Unit

- 11 Peel the release paper of the tape on the back of each end cap and attach the end cap while aligning with the marked end cap fixing position.

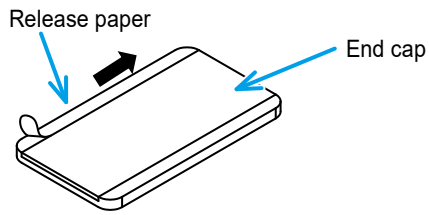

Tips

Attach the end caps to the end cap fixing position at both ends of the tape scale while aligning the concave part with the tape scale.

3.2.3 Specifications for Fixing at the Center

- 1 Fix the scale holder C, scale holder D, and center fixing base.

For details on the parallelism and flatness of the scale holder mounting area, refer to "2.2 Designing the Scale Mounting Surface" (page 11).

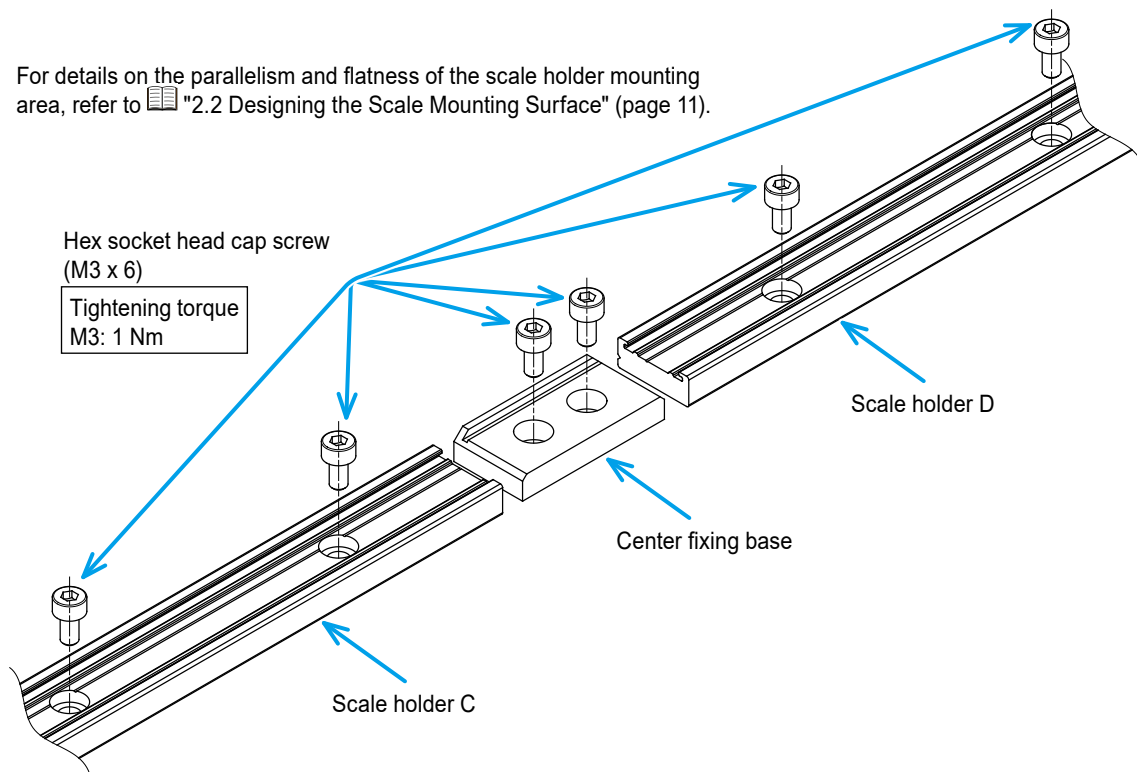

3 Installation onto the Machine Main Unit



- For the scale with the effective length of 2400 mm or more, fix as many scale holder E units and scale holder (998 mm) units as supplied.

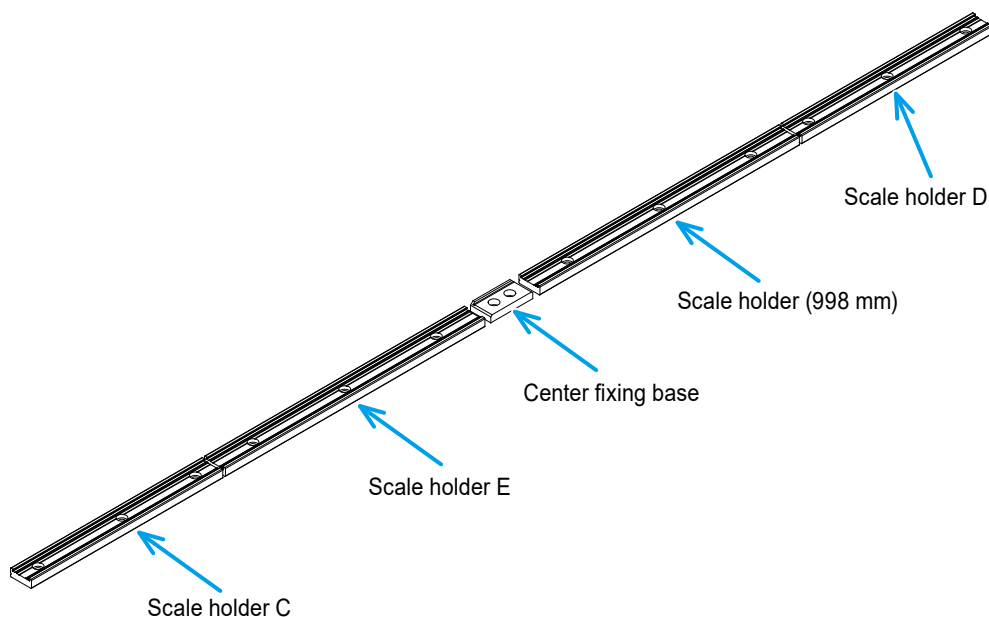

- For the scale with the effective length of 4400 mm or more, you also need to insert the scale holder (998 mm) between the scale holder C and the scale holder E.

- 2 Peel the scale protection tape.

Tips

Wipe the tape scale thoroughly with a soft cloth soaked in ethanol or cleaning paper.

- 3 Insert the tape scale into the scale holder.

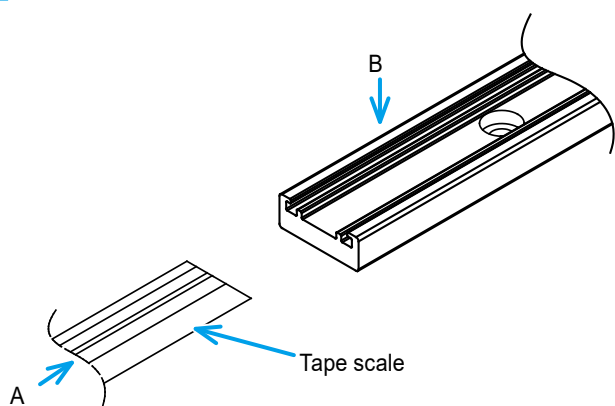

3 Installation onto the Machine Main Unit



Make sure that the tape scale is inserted into the scale holder in the correct scale pattern direction.

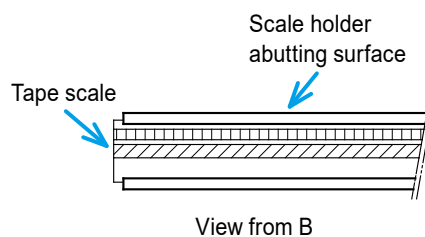
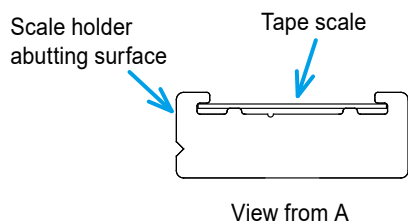

4 Fix the tape scale with the center fixing spring.

Hex socket head cap screw (M3 x 6)
and plain washer (small round, M3)

Tightening torque
M3: 1 Nm

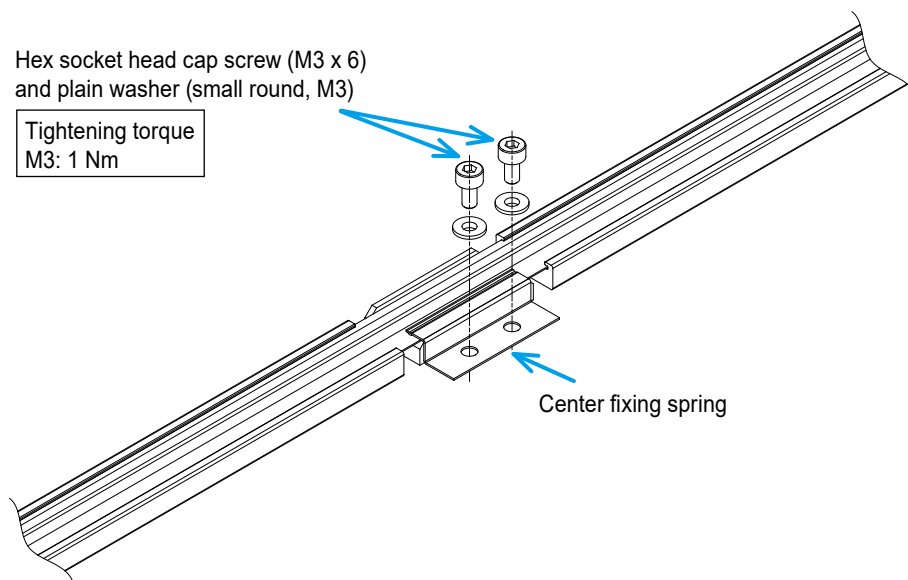

3.3 Mounting the Detector Bracket and Detector

NOTICE

Do not directly touch the electrical connector pins during the Detector installation. Otherwise, electronic parts may be damaged by static electricity. Be sure to take measures to prevent static electricity for the Detector installation.



To use the scale with the Detector mounted, the machine main unit, as well as the attachment bracket, must be electrically grounded. Failure to do so may cause the scale unit and the Detector to be affected by external noise. When it is difficult to ground due to the characteristics of the bracket material, make sure that the shielded part of the Detector cable is grounded using a ground bar.

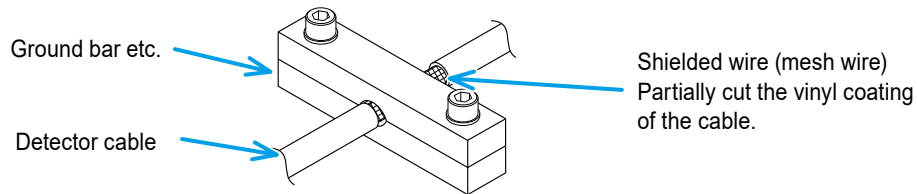

Example: Drawing of using a ground bar

- 1 Peel the protection tape (blue) off the detecting surface of the Detector.

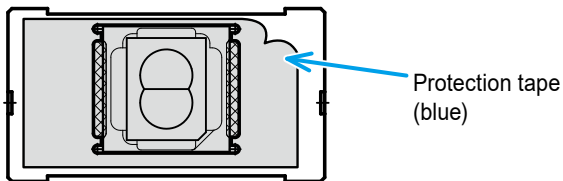

3 Installation onto the Machine Main Unit

2 Attach the Detector to the Detector bracket.

■ Specifications for fixing at both ends or fixing at the center

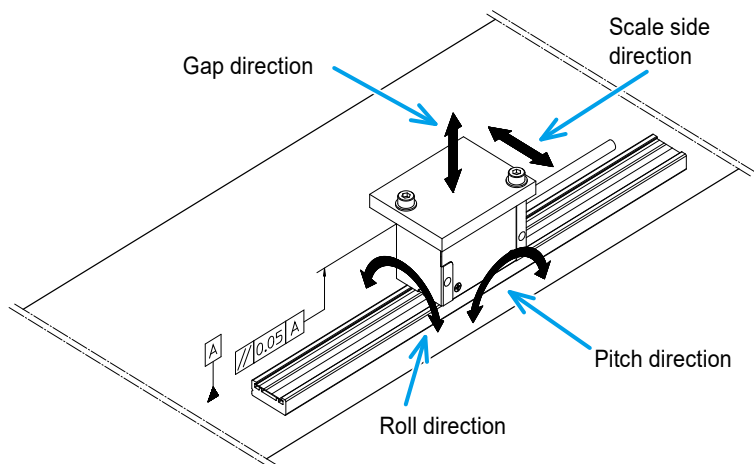

■ Specifications for fixing with double-sided tape

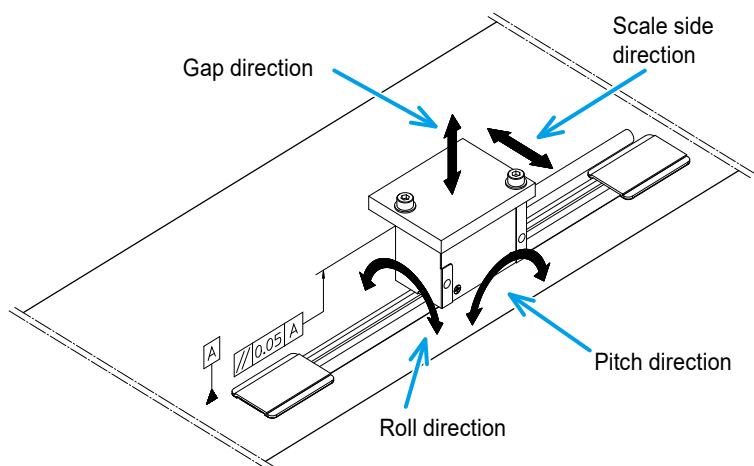

3 Installation onto the Machine Main Unit

- 3 Insert the mounting auxiliary tool between the tape scale and the Detector.

Tips

If a space for inserting the mounting auxiliary tool is small, cut the mounting auxiliary tool in the middle.

■ Specifications for fixing at both ends or fixing at the center

- 1 Insert the mounting auxiliary tool (for fixing at both ends or fixing at the center) in the arrow direction.

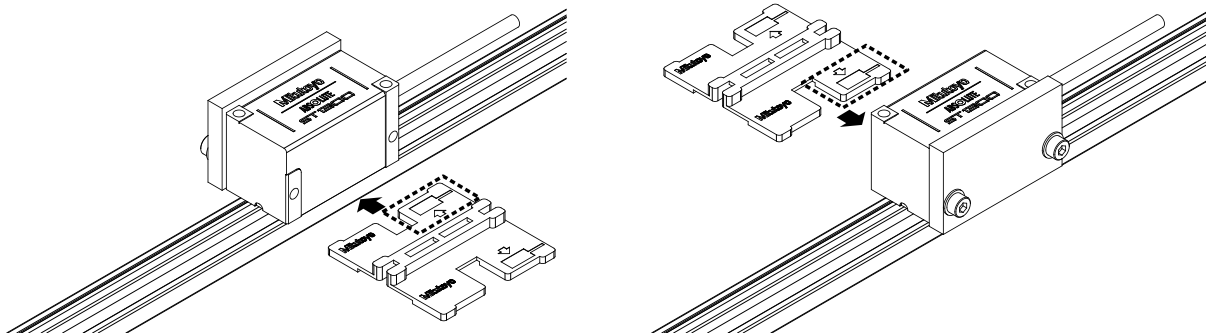

■ Specifications for fixing with double-sided tape

- 1 Insert the mounting auxiliary tool (for fixing with double-sided tape) in the arrow direction.

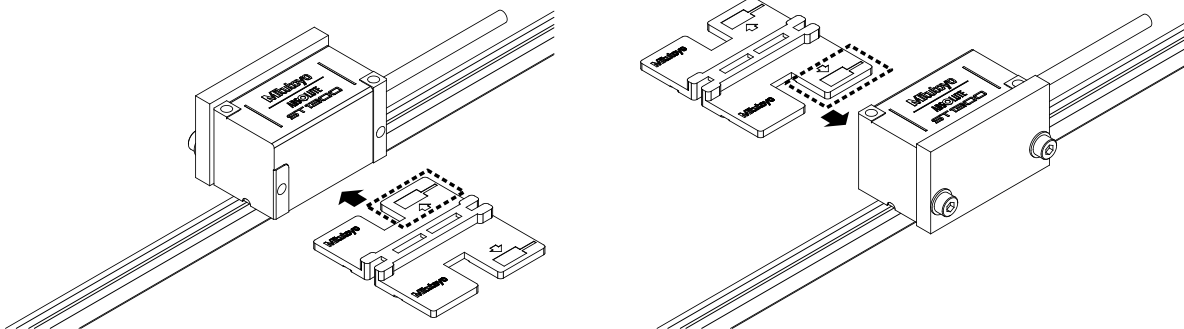

3 Installation onto the Machine Main Unit

- 4 Temporarily fix the Detector while pressing it against the mounting auxiliary tool.

■ Specifications for fixing at both ends or fixing at the center

- 1 Press the tip of the mounting auxiliary tool (for fixing at both ends or fixing at the center) against the bottom end inside the scale holder.

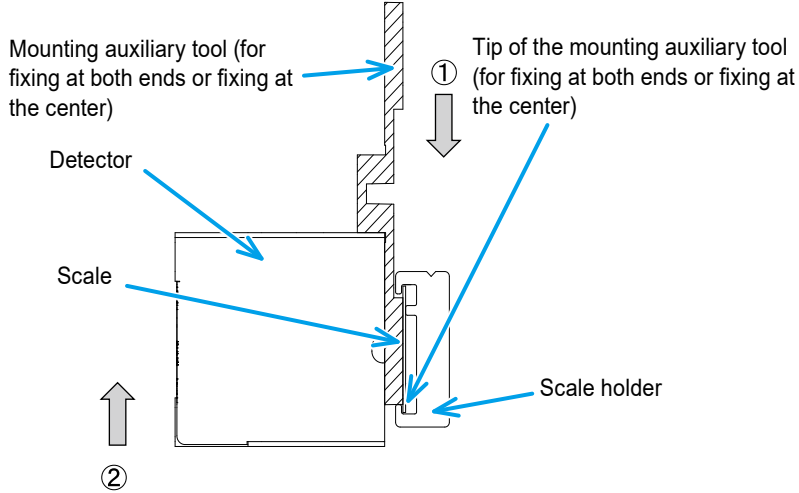

- 2 With the mounting auxiliary tool (for fixing at both ends or fixing at the center) pressed against the scale holder, temporarily fix the Detector while pressing it against the step on the front of the mounting auxiliary tool (for fixing at both ends or fixing at the center).

■ Specifications for fixing with double-sided tape

- 1 Press the step on the back of the mounting auxiliary tool (for fixing with double-sided tape) against the side of the scale.

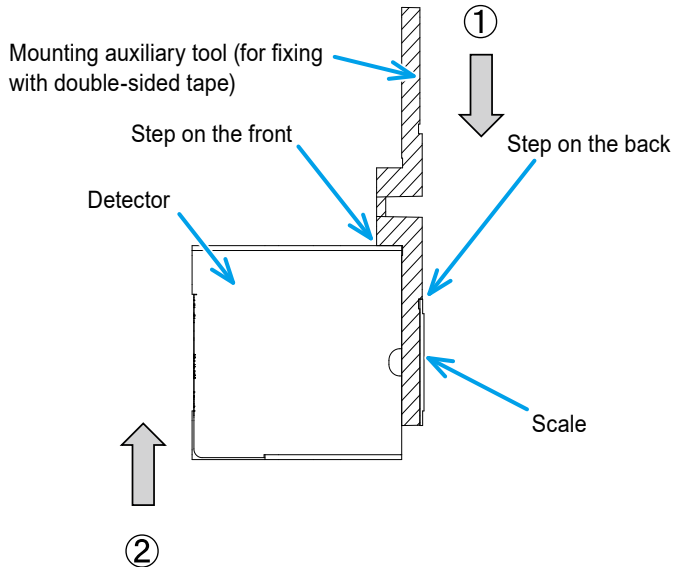

- 2 With the mounting auxiliary tool (for fixing with double-sided tape) pressed against the scale, temporarily fix the Detector while pressing it against the step on the front of the mounting auxiliary tool (for fixing with double-sided tape).

- 5 Check the parallelism of the Detector against the tape scale with a lever-type dial indicator or electric micrometer.



The parallelism of the Detector against the tape scale must be within 0.05 mm.

- 6 Make sure that the distance between the Detector and the tape scale is within the specified value (gap: 2.0 ± 0.1 mm) with the mounting auxiliary tool (for fixing at both ends or fixing at the center) or mounting auxiliary tool (for fixing with double-sided tape).

- 7 Fix the Detector (recommended screw tightening torque: 1 Nm).

3.4 Connecting the Feedback Cable and Checking the Signals



- Be sure to turn off the control unit before connecting the scale unit to the control unit with a feedback cable.
- A feedback cable must be prepared by the user. Find a cable that supports your model according to  "4.4 Production of a Feedback Cable" (page 50) and "4.4.6 Calculation of Feedback Cable Length" (page 53).

- 1 Connect the electrical connector to the control unit with the feedback cable.

- 2 Turn on the control unit.

» The electrical connector LED (yellow) and LED (red) turn on for about 2 seconds.

- 3 Check the signals.

» For details, refer to "ABS ST1300 Series Signal Check Program User's Manual" (No. 99MBE085B).

3.5 Handling the Cables and Checking the Mounting State

3.5.1 Handling the Cables

Fix the electrical connector and feedback cable.

- 1 Perform wiring paying attention to the twisting or bends of the cables.

NOTICE

Note that the feedback cable may malfunction if bundled with other cables that may cause electrical noise, or if it is located near a switching relay dealing with a large current.

- 2 Fix the Detector cable and feedback cable with cable clamps.



Clamp the feedback cable to a nearby part that moves along with the Detector so that force is not applied to the Detector when the machine unit is running.



Be sure to fix the electrical connector to the machine main unit with screws.

3.5.2 Checking the Mounting and Adjustment States

After fixing the electrical connector and feedback cable, check the mounting and adjustment states of the tape scale and Detector again.

Tips

Perform this operation while making sure that the Detector does not make contact or interfere with any part of the machine unit or tape scale.

- 1 Make sure that all the part screws and clamps are firmly tightened.

- 2 Turn off the control unit and turn it on again after 5 to 10 seconds.

Tips

Turning off the control unit resets the alarm that occurred during adjustment.

- 3 Make sure that no electrical connector LEDs turn on throughout the entire travel range of the machine unit.

Tips

If an electrical connector LED lights up, check the tape scale for any dirt or the Detector moire/gap again.

- 4 Make sure that no control unit alarm occurs throughout the entire travel range of the machine unit.

3.5.3 Putting the Protection Cover

After checking the mounting and adjustment states of the tape scale and Detector again, put the protection cover.

3 Installation onto the Machine Main Unit



- Make sure that the protection cover does not make contact with any machine unit part or scale unit cable.
- Check the above for the entire travel range of the machine unit.

MEMO

4 Specifications

4.1 Specifications

4.1.1 Specifications for Fixing at Both Ends

Item	Specification
Detection method	Optical system
Scale type	Metal tape
Maximum effective length	12 m
Indication accuracy (20 °C) (*1)	±5 μm (1 m or less) ±5 μm/m (1.1 m or more)
Tape scale grid pitch	20 μm
Main signal (sine wave) output pitch	20 μm
Resolution	0.001 μm/0.01 μm (fixed to one of the two depending on the model)
Maximum Response Speed	8 m/s
Supported interface	Mitutoyo ENSIS®, Mitsubishi I/F, FANUC I/F, Yaskawa I/F, Panasonic I/F
Thermal expansion coefficient	Scale material ≈ 10 x 10 ⁻⁶ /K (*2)
GAP allowance	Initial: ±0.1 mm Kinetic: ±0.2 mm
Detector cable length	1 m (highly flexible cable)
Maximum cable length	29 m (including the Detector cable length)
Detector size	40 mm (D) x 22 mm (W) x 23 mm (H)
Power supply voltage	5 VDC ± 10 %
Maximum current consumption	270 mA (Mitutoyo, Mitsubishi, FANUC, Yaskawa) 250 mA (Panasonic)
Used temperature range	0 °C–50 °C
Storage temperature range	-20 °C–70 °C
Used/storage humidity range	20 %RH–80 %RH (non condensation)
Vibration resistance	≤100 m/s ² (55 Hz–2000 Hz)
Shock resistance	≤200 m/s ² (1/2 sin, 11 ms)
CE marking	EMC Directive: EN 61326-1 Immunity test requirement: Clause 6.2 Table 2 Emission limit: Class B RoHS Directive: EN IEC 63000

*1: The accuracy needs to be corrected throughout the system because the scale is pulled at 250 μm/m to stabilize the temperature characteristics.

*2: The thermal expansion coefficient after installation depends on the expansion of the mounting surface due to changes in outside air.

4.1.2 Specifications for Fixing with Double-Sided Tape

Item	Specification	
Detection method	Optical system	
Scale type	Metal tape	
Maximum effective length	3 m	
Indication accuracy (20 °C)	±5 μm (1 m or less) ±5 μm/m (1.1 m or more)	
Tape scale grid pitch	20 μm	
Main signal (sine wave) output pitch	20 μm	
Resolution	0.001 μm/0.01 μm (fixed to one of the two depending on the model)	
Maximum Response Speed	8 m/s	
Supported interface	Mitutoyo ENSIS®, Mitsubishi I/F, FANUC I/F, Yaskawa I/F, Panasonic I/F	
Thermal expansion coefficient	Scale material ≈ 10 × 10 ⁻⁶ /K (*1)	
GAP allowance	Initial: ±0.1 mm Kinetic: ±0.2 mm	
Detector cable length	1 m (highly flexible cable)	
Maximum cable length	29 m (including the Detector cable length)	
Detector size	40 mm (D) x 22 mm (W) x 23 mm (H)	
Power supply voltage	5 VDC ± 10 %	
Maximum current consumption	270 mA (Mitutoyo, Mitsubishi, FANUC, Yaskawa) 250 mA (Panasonic)	
Mounting material	Equivalent to iron	Other than equivalent to iron
Used temperature range	0 °C–50 °C	0 °C–50 °C Installation temperature ±10 °C (*2)
Storage temperature range	-20 °C–70 °C	-20 °C–70 °C (*3)
Used/storage humidity range	20 %RH–80 %RH (non condensation)	
Vibration resistance	≤100 m/s ² (55 Hz–2000 Hz)	
Shock resistance	≤200 m/s ² (1/2 sin, 11 ms)	
CE marking	EMC Directive: EN 61326-1 Immunity test requirement: Clause 6.2 Table 2 Emission limit: Class B RoHS Directive: EN IEC 63000	

*1: When the difference in thermal expansion coefficient between the scale material and the attachment surface material is large, the thermal expansion coefficient value may change.

*2: When the attachment surface is other than equivalent to iron, there will be conditions on the used temperature range.

*3: When the attachment surface is other than equivalent to iron, if the machine is stored in an environment outside the used temperature range, the accuracy may change. If such a circumstance is expected, it is recommended that the specifications for fixing at both ends should be used.

4.1.3 Specifications for Fixing at the Center

Item	Specification	
Detection method	Optical system	
Scale type	Metal tape	
Maximum effective length	6 m	
Indication accuracy (20 °C)	With the system parameters ±5 μm (1 m or less) ±5 μm/m (1.1 m or more)	Without the system parameters ±10 μm (1 m or less) ±10 μm/m (1.1 m or more)
Tape scale grid pitch	20 μm	
Main signal (sine wave) output pitch	20 μm	
Resolution	0.001 μm/0.01 μm (fixed to one of the two depending on the model)	
Maximum Response Speed	8 m/s	
Supported interface	Mitutoyo ENSIS®, Mitsubishi I/F, FANUC I/F, Yaskawa I/F, Panasonic I/F	
Thermal expansion coefficient	Scale material ≈ 10 x 10 ⁻⁶ /K	
GAP allowance	Initial: ±0.1 mm Kinetic: ±0.2 mm	
Detector cable length	1 m (highly flexible cable)	
Maximum cable length	29 m (including the Detector cable length)	
Detector size	40 mm (D) x 22 mm (W) x 23 mm (H)	
Power supply voltage	5 VDC ± 10 %	
Maximum current consumption	270 mA (Mitutoyo, Mitsubishi, FANUC, Yaskawa) 250 mA (Panasonic)	
Used temperature range	0 °C–50 °C	
Storage temperature range	-20 °C–70 °C	
Used/storage humidity range	20 %RH–80 %RH (non condensation)	
Vibration resistance	≤100 m/s ² (55 Hz–2000 Hz)	
Shock resistance	≤200 m/s ² (1/2 sin, 11 ms)	
CE marking	EMC Directive: EN 61326-1 Immunity test requirement: Clause 6.2 Table 2 Emission limit: Class B RoHS Directive: EN IEC 63000	

4.2 Relationship between the Resolution, Maximum Effective Length, and Maximum Response Speed

4.2.1 Resolution: 0.01 μm

Interface	Maximum effective length (mm)			Maximum response speed (m/s)
	Specifications for fixing at both ends	Specifications for fixing with double-sided tape	Specifications for fixing at the center	
Mitutoyo ENSIS®	12000	3000	6000	8
Mitsubishi Electric Corporation	12000	3000	6000	4
FANUC Corporation	12000	3000	6000	8
Panasonic Corporation	12000	3000	6000	4
Yaskawa Electric Corporation	12000	3000	6000	8

4.2.2 Resolution: 0.001 μm

■ When the center of maximum effective length is set as zero

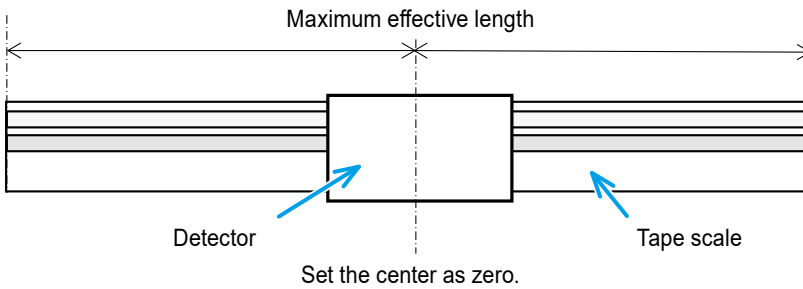

Interface	Maximum effective length (mm)			Maximum response speed (m/s)
	Specifications for fixing at both ends	Specifications for fixing with double-sided tape	Specifications for fixing at the center	
Mitutoyo ENSIS®	±2100	±1500	±2100	8
Mitsubishi Electric Corporation	±2100	±1500	±2100	4
FANUC Corporation	±2100	±1500	±2100	8
Panasonic Corporation	±2100	±1500	±2100	0.4
Yaskawa Electric Corporation	±1800	±1500	±1800	3.6

Tips

The center of maximum effective length is factory set as zero (origin).

■ When the scale end is set as zero

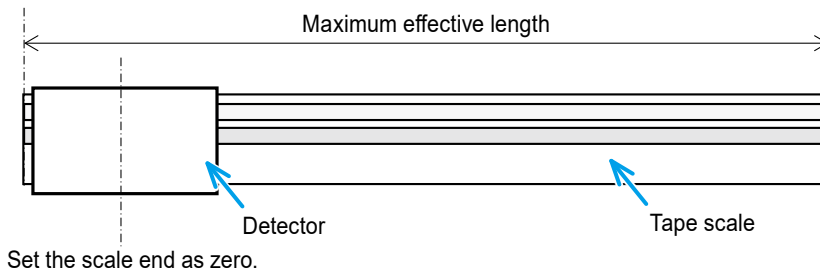

Tips

When zero is set to the scale end, the maximum effective length is different from that of the scale center.

Interface	Maximum effective length (mm)			Maximum response speed (m/s)
	Specifications for fixing at both ends	Specifications for fixing with double-sided tape	Specifications for fixing at the center	
Mitutoyo ENSIS®	0—+2100 or -2100—0			8
Mitsubishi Electric Corporation	0—+2100 or -2100—0			4
FANUC Corporation	0—+2100 or -2100—0			8
Panasonic Corporation	0—+2100 or -2100—0			0.4
Yaskawa Electric Corporation	0—+1800 or -1800—0			3.6

4.3 Data Zero Position and Counting Direction

When the center of maximum effective length is set as zero, the electrical connector direction is the + count direction.

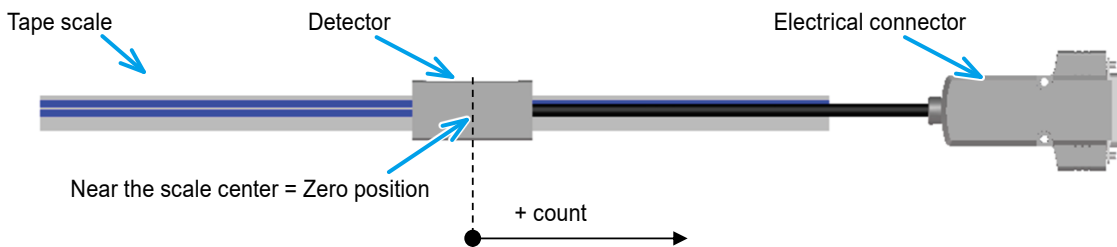

4.4 Production of a Feedback Cable

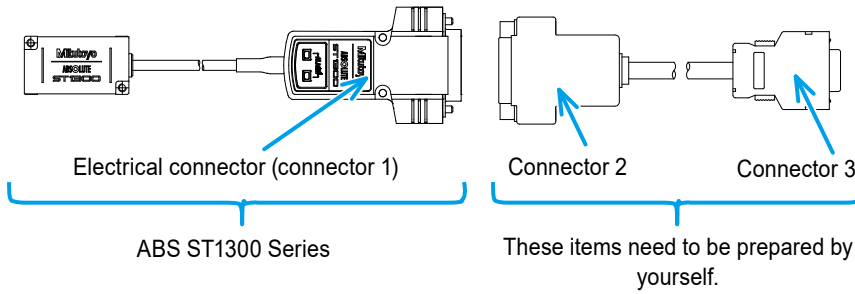

- If you use the machine in an environment affected by electromagnetic noise, partially remove the sheath of the feedback cable near the servo amplifier and connect the shielded wire to the ground bar to improve noise resistance.
- To set the cable length longer, it is recommended that you should wire the dotted lines (+5 V, 0 V) as shown in the following connection diagrams.

Tips

The pin assignment of the electrical connector (connector 1) is as follows. The applicable connector is HDAB-15S.

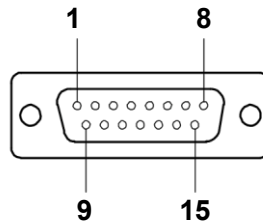

4.4.1 Connection Diagram for ABS ST1301A/ABS ST1302A

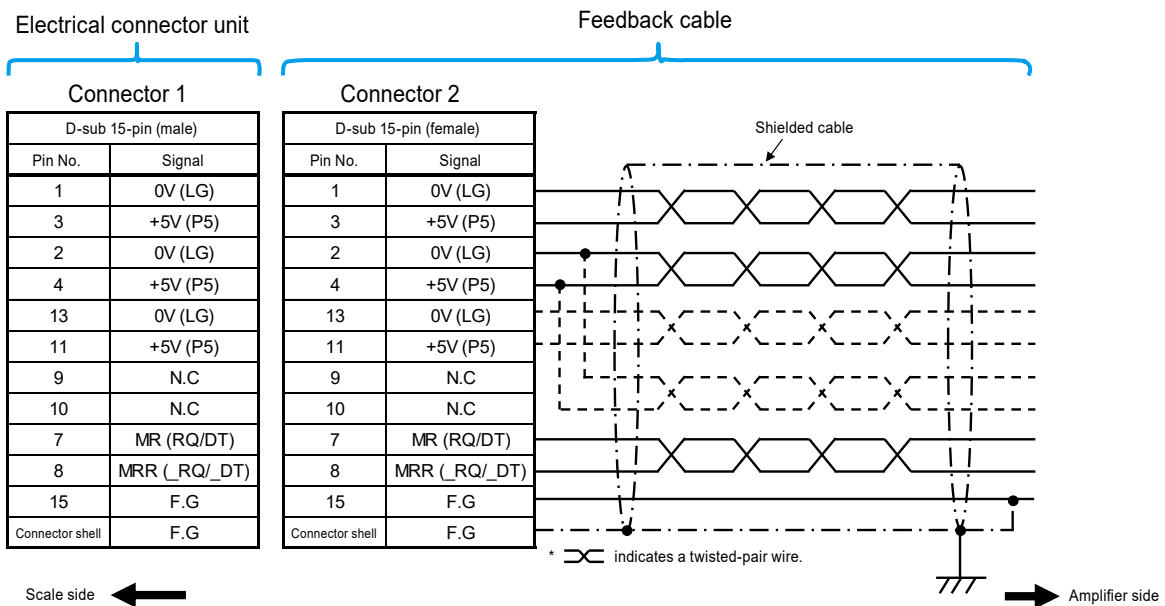

4.4.2 Connection Diagram for ABS ST1341A/ABS ST1342A

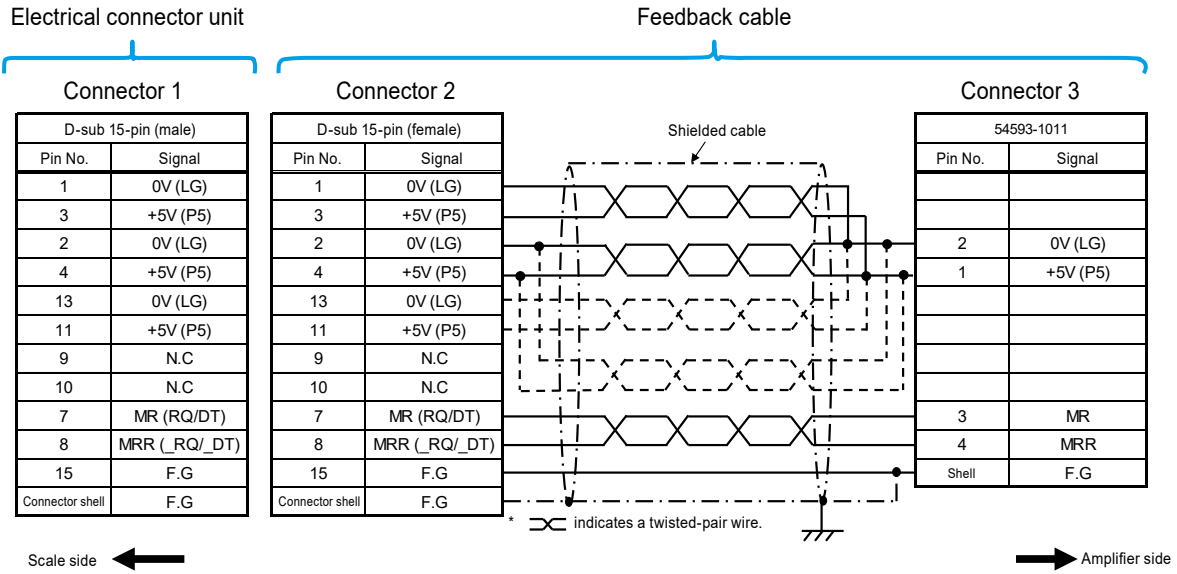

4.4.3 Connection Diagram for ABS ST1351/ABS ST1352

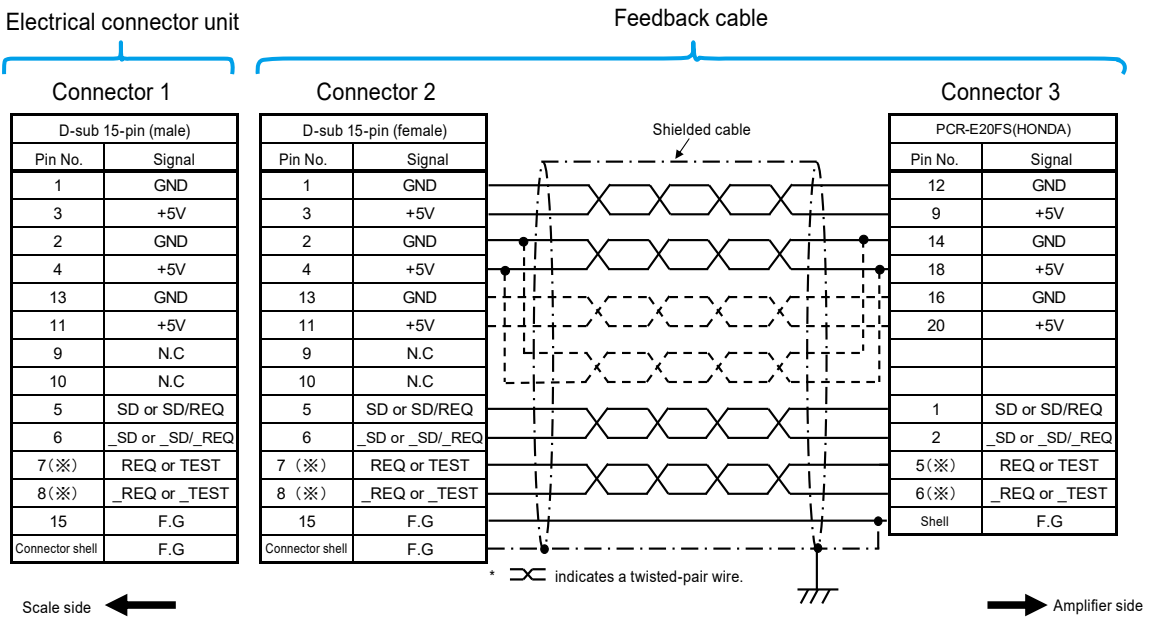

Be sure to connect the TEST/_TEST signals as they are used as communication lines during signal check.

4.4.4 Connection Diagram for ABS ST1371A/ABS ST1372A

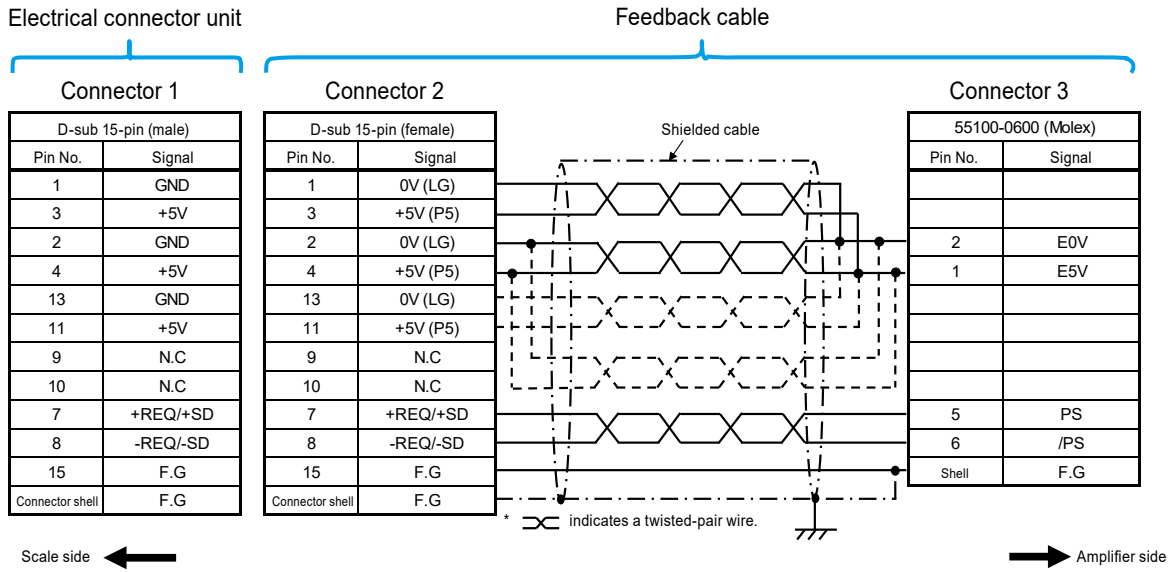

4.4.5 Connection Diagram for ABS ST1381A/ABS ST1382A

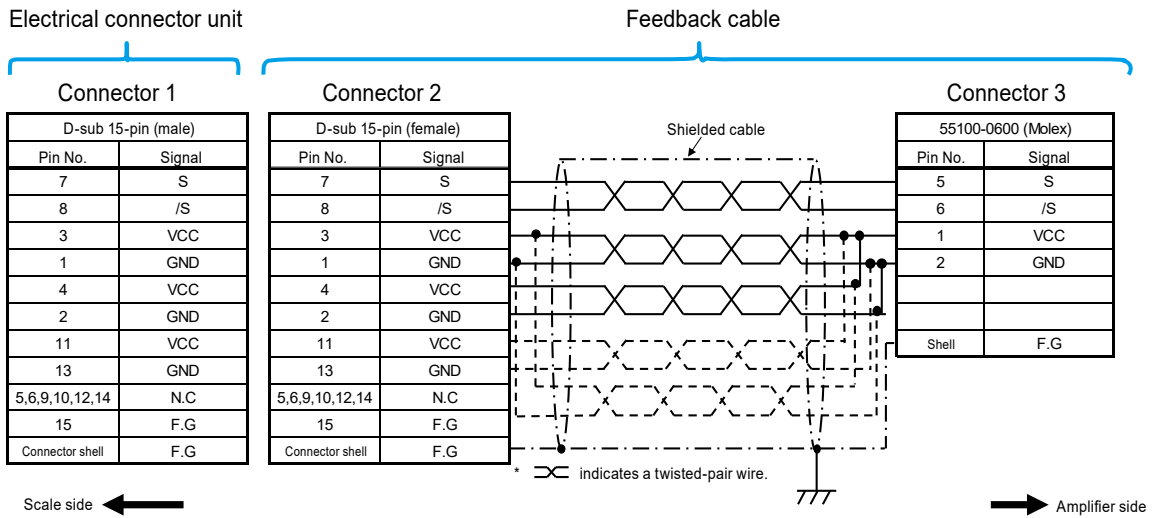

4.4.6 Calculation of Feedback Cable Length

When making a feedback cable, refer to the following calculation method of maximum cable length.

■ Configuration

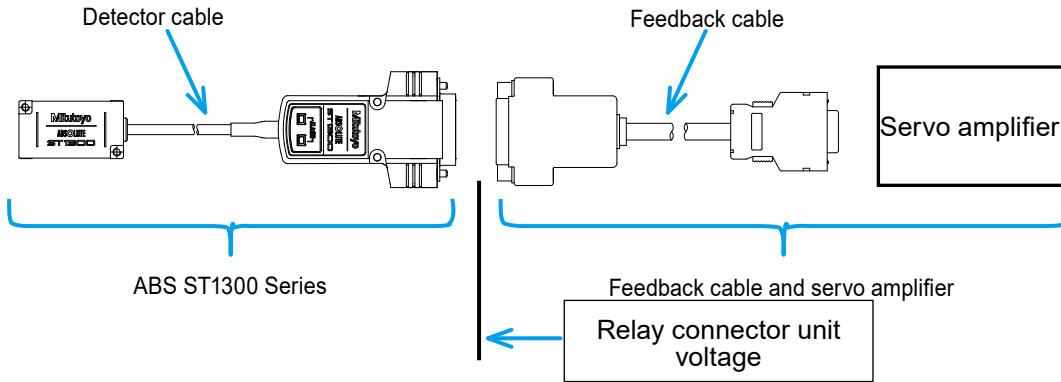

■ Condition: When the Detector cable length is 1 m

Name	Specifications and symbols	Unit
Maximum cable length	L	m
Wire resistance of used wire material	a	Ω/m
Number of pairs used for power supply line	b	Wires
Supply voltage (minimum value) from the servo amplifier	Vin (*1)	V
Current consumption value	I (*2)	A
Relay connector unit voltage (minimum value)	4.5	V

*1: This is the standard supply voltage from the servo amplifier.

*2: For details on the current consumption value, refer to 4.1 Specifications" (page 45).

■ Calculation formula

$$\text{Allowable voltage drop} \geq (\text{Current consumption} \times \text{wire material resistance} \times 2 \times \text{max cable length}) \div \text{Number of pairs used for power supply line} \tag{1}$$

Applying the conditions in the above table to formula (1) gives the following result.

$$(V_{in} - 4.5) [V] \geq (I [A] \times a [\Omega/m] \times 2 \times L [m]) \div b [\text{wires}] \tag{2}$$

Modify formula (2) above to the following one.

$$L [m] \leq \frac{b (V_{in} - 4.5)}{2 \times I \times a} \tag{3}$$

Produce the feedback cable of the max cable length (L[m]), wire resistance of used wire material (a[Ω/m]) and number of pairs used for power supply line (b[wires]) satisfying formula (3) above.

4.5 Alarm Function

The ABS ST1300 Series is equipped with the Alarm Detection function inside the Detector. Alarms detected by the Alarm Detection function can be categorized into two groups as follows: Caution and Error.

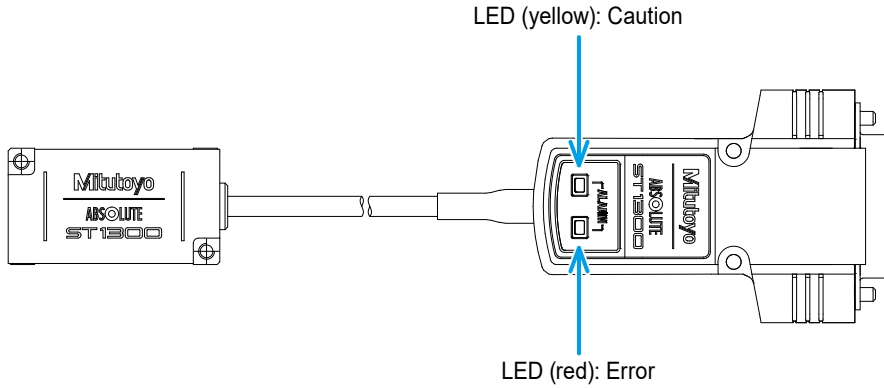

- Caution: Indicates a low-level sensor signal strength or temperature rise inside the Detector. Once troubleshoot the causes, the normal state is restored.
- Error: Indicates a sensor signal strength error or absolute position detection error. Once it occurs, the error state will be maintained until the error is reset, or the power is re-supplied.

Alarm detection type	Description	
Caution	Signal strength alarm	<ul style="list-style-type: none"> • It is output when the signal strength of the scale is too large or too small. There is no error in the position data, but check the mounting position relationship between the tape scale and the Detector. • When the signal strength returns to the predetermined range, the alarm is canceled.
	Thermal alarm	<ul style="list-style-type: none"> • It is output when the temperature inside the Detector rises above 65 °C. • There is no error in the position data, but continuing to use it may cause a malfunction. Review the usage conditions or the installation environment.
Error	Over speed error	It is output when the speed of 8 m/s or more occurs.
	Initialization error	It is output when an error cause occurs during initialization immediately after turning on the power or receiving the reset ID.
	Hardware error	It is output when abnormality occurs in self-diagnosis.
	ABS detection error	It is output when an error occurs in the combination of absolute positions.
	Communication error	It is output when a communication error between the Detector and the electrical connector occurs.
	Signal strength error	It is output when the signal strength of the scale is too large or too small and there is a possibility of abnormality in the output data.

4.6 Maintenance Parts/Optional Parts

There are the following maintenance parts and optional parts available for the ABS ST1300 Series.

4.6.1 Maintenance Parts

■ Specifications for fixing at both ends

Name	Part number	Note
Mounting auxiliary tool (for fixing at both ends or fixing at the center)	06AFT403	
Pull block A	06AEY098	
Pull block B	06AEY099	
Fixing base	06AEY100	
Sleeve washer	06AEX682	
Intermediate fixing spring Ass'y	06AEX686	
Intermediate fixing base	06AEY101	
Cover	06AEX690	
Countersunk screw M2 x 4	143032	Cover fixing screw

■ Specifications for fixing with double-sided tape

Name	Part number	Note
Mounting auxiliary tool (for fixing with double-sided tape)	06AFT404	
End cap	06AEF304	

■ Specifications for fixing at the center

Name	Part number	Note
Mounting auxiliary tool (for fixing at both ends or fixing at the center)	06AFT403	
Scale holder C	06AGF506	
Scale holder D	06AGF507	
Scale holder E	06AGF509	
Scale holder (998 mm)	06AGF509S	
Center fixing base	06AGB360	
Center fixing spring	06AFZ195	

4.6.2 Optional Parts

Name	Part number	Note
ST1300A Signal Check Program conversion unit	06AFA406	Used to check the signals
ST1340A Signal Check Program conversion unit	06AEX139	
ST1350 Signal Check Program conversion unit	06AFA407	
ST1370A/ST1380A Signal Check Program conversion unit	06AEX140	
Roller	06AEJ505	Used to attach the tape scale (specifications for fixing with double-sided tape)
Scale attaching auxiliary tool	06AEQ305	
ST1380A connection cable (L = 200 mm)	06AFA434A	Used to use the Yaskawa Electric feedback cable
ST1380A connection cable (L = 500 mm)	06AFA434B	
ST1380A connection cable (L = 1000 mm)	06AFA434C	

4.6.3 Cutting the Tape Scale



You need to prepare a tape scale cutting tool that can cut the following materials:

- Material: SUS material
- Thickness: 0.3 mm
- Width: 13 mm

1 Mark the cutting position.

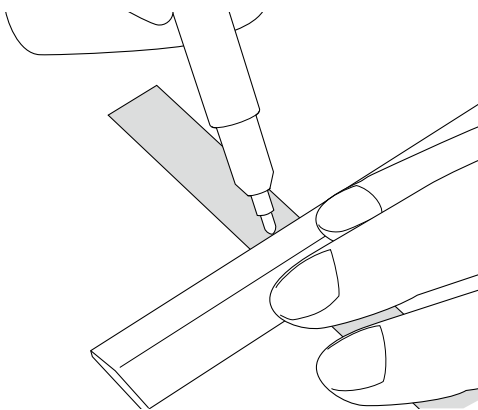

4 Specifications

- 2** Set the tape scale on the cutting tool.

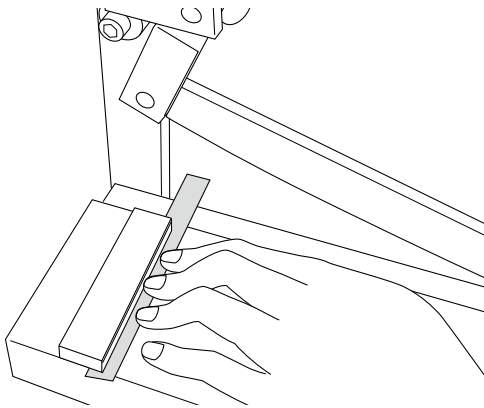

- 3** Cut the tape scale.

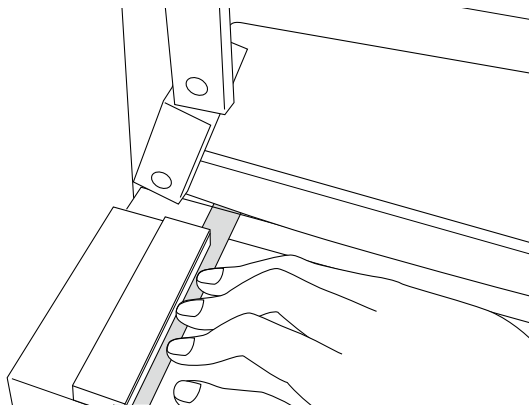

- 4** Remove burrs from the cutting surface with an oilstone.

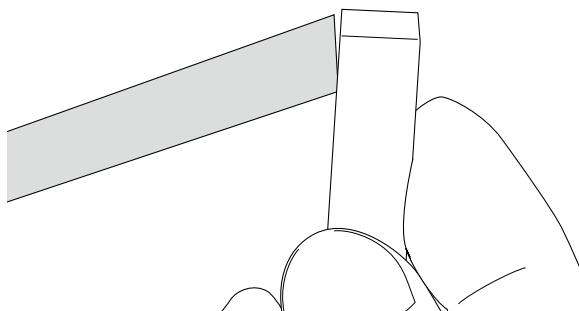

4.7 External View and Dimensional Drawings

4.7.1 Specifications for Fixing at Both Ends (Effective Length of 500 mm–1000 mm)

■ Dimensional drawings

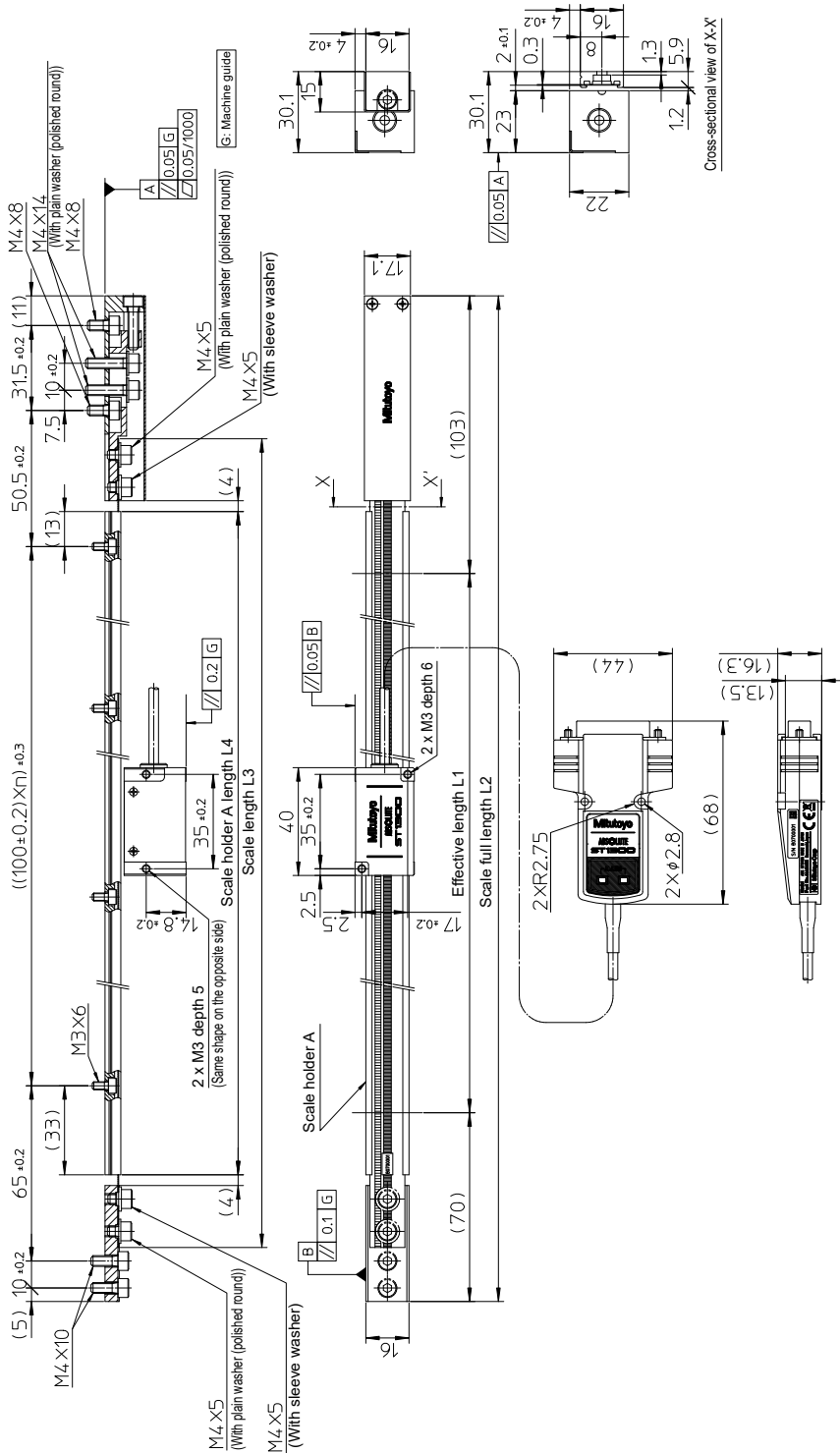

■ Dimensional drawings table

Code No. (*1, *2)	Model number (*1, *2, *3)	Effective length L1 (mm)	Scale full length L2 (mm)	Scale length L3 (mm)	Scale holder A length L4 (mm)	Number of scale holder A mounting holes n
579-434-□◇	ST13□◇△-00500D	500	673	600	546	5
579-435-□◇	ST13□◇△-00600D	600	773	700	646	6
579-436-□◇	ST13□◇△-00700D	700	873	800	746	7
579-437-□◇	ST13□◇△-00800D	800	973	900	846	8
579-438-□◇	ST13□◇△-00900D	900	1073	1000	946	9
579-439-□◇	ST13□◇△-01000D	1000	1173	1100	1046	10

*1: The □ mark in Code No. and Model number represents as follows:

0: Mitutoyo ENSIS® specifications Compatible with high-speed serial interface

4: Mitsubishi Electric Corporation specifications Compatible with high-speed serial interface

5: FANUC Corporation specifications Compatible with high-speed serial interface

7: Panasonic Corporation specifications Compatible with high-speed serial interface

8: Yaskawa Electric Corporation specifications Compatible with high-speed serial interface

*2: The ◇ mark in Code No. and Model number represents as follows:

1: Resolution 0.01 μm

2: Resolution 0.001 μm

*3: The △ mark in Model number represents as follows:

A: Half duplex system

None: Full duplex system or full duplex system/half duplex system

4.7.2 Specifications for Fixing at Both Ends (Effective Length of 1100 mm–12000 mm)

■ Dimensional drawings

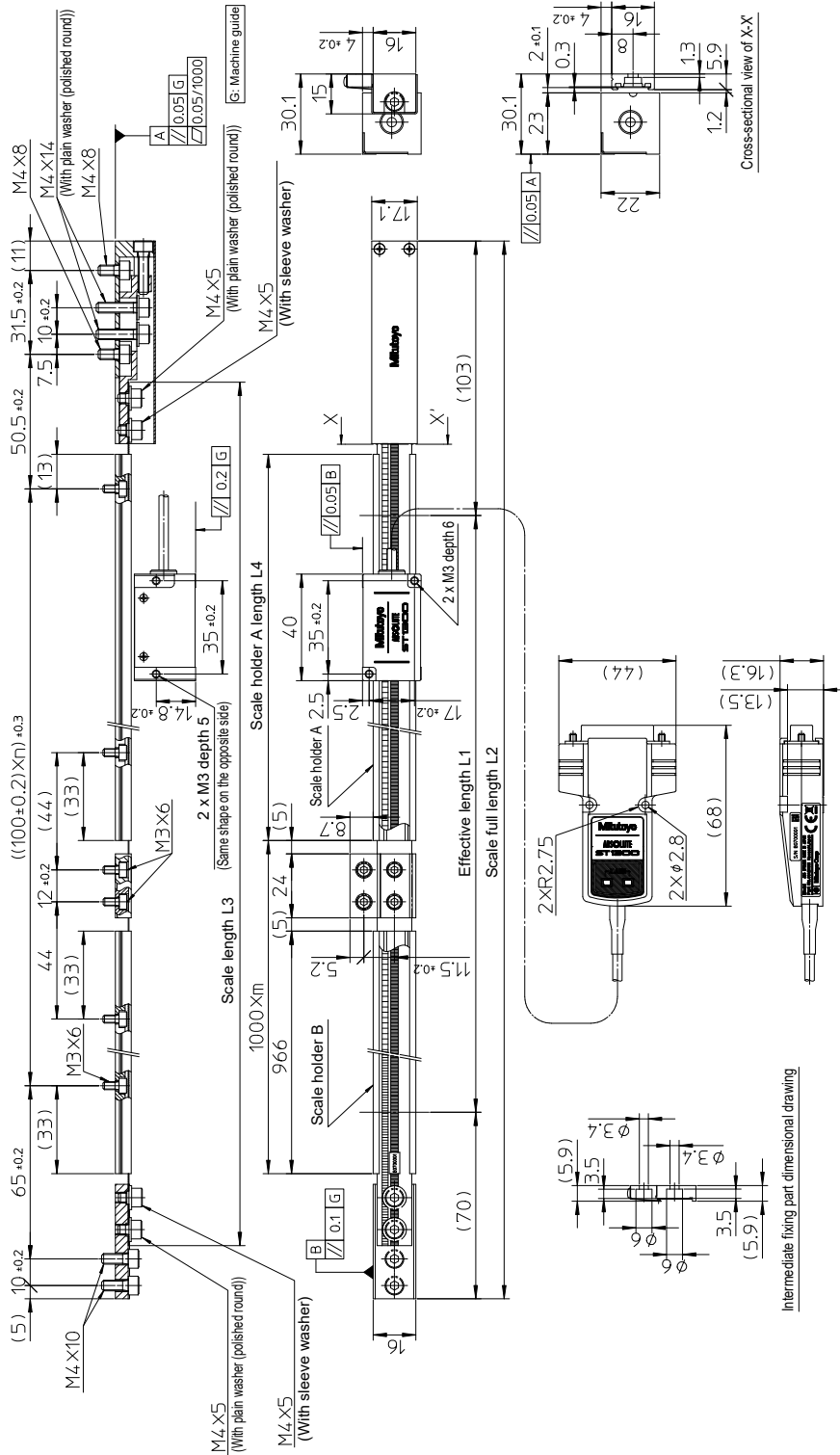

■ Dimensional drawings table

Code No. (*1, *2)	Model number (*1, *2, *3)	Effective length L1 (mm) (*4)	Scale full length L2 (mm)	Scale length L3 (mm)	Scale holder A length L4 (mm)	Number of scale holder B units/inter- mediate fixing base units/ intermediate fixing spring Ass'y units	Number of scale holder mounting holes n
579-440-□◇	ST13□◇△-01100D	1100	1273	1200	146	1	11
579-441-□◇	ST13□◇△-01200D	1200	1373	1300	246	1	12
579-442-□◇	ST13□◇△-01300D	1300	1473	1400	346	1	13
579-443-□◇	ST13□◇△-01400D	1400	1573	1500	446	1	14
579-444-□◇	ST13□◇△-01500D	1500	1673	1600	546	1	15
579-445-□◇	ST13□◇△-01600D	1600	1773	1700	646	1	16
579-446-□◇	ST13□◇△-01700D	1700	1873	1800	746	1	17
579-447-□◇	ST13□◇△-01800D	1800	1973	1900	846	1	18
579-448-□◇	ST13□◇△-02000D	2000	2173	2100	1046	1	20
579-449-□◇	ST13□◇△-02200D	2200	2373	2300	246	2	22
579-450-□◇	ST13□◇△-02400D	2400	2573	2500	446	2	24
579-451-□◇	ST13□◇△-02500D	2500	2673	2600	546	2	25
579-452-□◇	ST13□◇△-02600D	2600	2773	2700	646	2	26
579-453-□◇	ST13□◇△-02800D	2800	2973	2900	846	2	28
579-454-□◇	ST13□◇△-03000D	3000	3173	3100	1046	2	30
579-455-□◇	ST13□◇△-03200D	3200	3373	3300	246	3	32
579-456-□◇	ST13□◇△-03400D	3400	3573	3500	446	3	34
579-457-□◇	ST13□◇△-03600D	3600	3773	3700	646	3	36
579-458-□◇	ST13□◇△-03800D	3800	3973	3900	846	3	38
579-459-□◇	ST13□◇△-04000D	4000	4173	4100	1046	3	40
579-460-□◇	ST13□◇△-04200D	4200	4373	4300	246	4	42
579-461-□◇	ST13□◇△-04400D	4400	4573	4500	446	4	44
579-462-□◇	ST13□◇△-04600D	4600	4773	4700	646	4	46
579-463-□◇	ST13□◇△-04800D	4800	4973	4900	846	4	48
579-464-□◇	ST13□◇△-05000D	5000	5173	5100	1046	4	50
579-465-□◇	ST13□◇△-05200D	5200	5373	5300	246	5	52
579-466-□◇	ST13□◇△-05400D	5400	5573	5500	446	5	54
579-467-□◇	ST13□◇△-05600D	5600	5773	5700	646	5	56
579-468-□◇	ST13□◇△-05800D	5800	5973	5900	846	5	58
579-469-□◇	ST13□◇△-06000D	6000	6173	6100	1046	5	60
579-470-□◇	ST13□◇△-06200D	6200	6373	6300	246	6	62
579-471-□◇	ST13□◇△-06400D	6400	6573	6500	446	6	64
579-472-□◇	ST13□◇△-06600D	6600	6773	6700	646	6	66
579-473-□◇	ST13□◇△-06800D	6800	6973	6900	846	6	68
579-474-□◇	ST13□◇△-07000D	7000	7173	7100	1046	6	70
579-475-□◇	ST13□◇△-07200D	7200	7373	7300	246	7	72
579-476-□◇	ST13□◇△-07400D	7400	7573	7500	446	7	74
579-477-□◇	ST13□◇△-07600D	7600	7773	7700	646	7	76
579-478-□◇	ST13□◇△-07800D	7800	7973	7900	846	7	78
579-479-□◇	ST13□◇△-08000D	8000	8173	8100	1046	7	80

4 Specifications

579-480-□◇	ST13□◇△-08200D	8200	8373	8300	246	8	82
579-481-□◇	ST13□◇△-08400D	8400	8573	8500	446	8	84
579-482-□◇	ST13□◇△-08600D	8600	8773	8700	646	8	86
579-483-□◇	ST13□◇△-08800D	8800	8973	8900	846	8	88
579-484-□◇	ST13□◇△-09000D	9000	9173	9100	1046	8	90
579-485-□◇	ST13□◇△-09200D	9200	9373	9300	246	9	92
579-486-□◇	ST13□◇△-09400D	9400	9573	9500	446	9	94
579-487-□◇	ST13□◇△-09600D	9600	9773	9700	646	9	96
579-488-□◇	ST13□◇△-09800D	9800	9973	9900	846	9	98
579-489-□◇	ST13□◇△-10000D	10000	10173	10100	1046	9	100
579-490-□◇	ST13□◇△-10200D	10200	10373	10300	246	10	102
579-491-□◇	ST13□◇△-10400D	10400	10573	10500	446	10	104
579-492-□◇	ST13□◇△-10600D	10600	10773	10700	646	10	106
579-493-□◇	ST13□◇△-10800D	10800	10973	10900	846	10	108
579-494-□◇	ST13□◇△-11000D	11000	11173	11100	1046	10	110
579-495-□◇	ST13□◇△-11200D	11200	11373	11300	246	11	112
579-496-□◇	ST13□◇△-11400D	11400	11573	11500	446	11	114
579-497-□◇	ST13□◇△-11600D	11600	11773	11700	646	11	116
579-498-□◇	ST13□◇△-11800D	11800	11973	11900	846	11	118
579-499-□◇	ST13□◇△-12000D	12000	12173	12100	1046	11	120

*1: The □ mark in Code No. and Model number represents as follows:

0: Mitutoyo ENSIS® specifications Compatible with high-speed serial interface

4: Mitsubishi Electric Corporation specifications Compatible with high-speed serial interface

5: FANUC Corporation specifications Compatible with high-speed serial interface

7: Panasonic Corporation specifications Compatible with high-speed serial interface

8: Yaskawa Electric Corporation specifications Compatible with high-speed serial interface

*2: The ◇ mark in Code No. and Model number represents as follows:

1: Resolution 0.01 μm

2: Resolution 0.001 μm

*3: The △ mark in Model number represents as follows:

A: Half duplex system

None: Full duplex system or full duplex system/half duplex system

*4: For the model number ST1382A-xxxxxD, the effective length is up to 3600 mm.

4.7.3 Specifications for Fixing with Double-Sided Tape (Effective Length of 10 mm–3000 mm)

■ Dimensional drawings

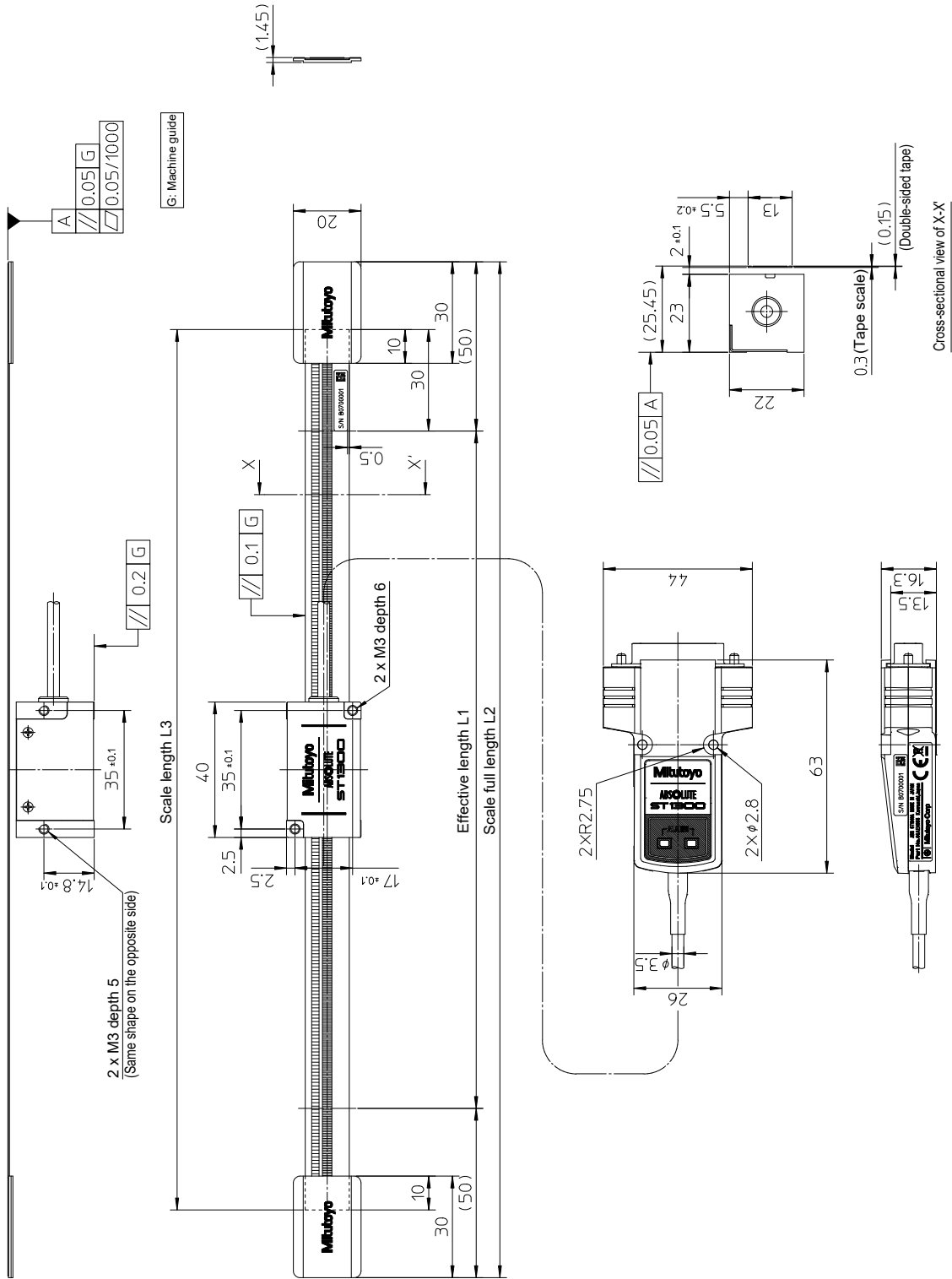

■ Dimensional drawings table

Code No. (*1, *2)	Model number (*1, *2, *3)	Effective length L1 (mm)	Scale full length L2 (mm)	Scale length L3 (mm)
579-401-□◇	ST13□◇△-00010E	10	110	70
579-402-□◇	ST13□◇△-00025E	25	125	85
579-403-□◇	ST13□◇△-00050E	50	150	110
579-404-□◇	ST13□◇△-00075E	75	175	135
579-405-□◇	ST13□◇△-00100E	100	200	160
579-406-□◇	ST13□◇△-00150E	150	250	210
579-407-□◇	ST13□◇△-00200E	200	300	260
579-408-□◇	ST13□◇△-00250E	250	350	310
579-409-□◇	ST13□◇△-00300E	300	400	360
579-410-□◇	ST13□◇△-00350E	350	450	410
579-411-□◇	ST13□◇△-00400E	400	500	460
579-412-□◇	ST13□◇△-00450E	450	550	510
579-413-□◇	ST13□◇△-00500E	500	600	560
579-414-□◇	ST13□◇△-00600E	600	700	660
579-415-□◇	ST13□◇△-00700E	700	800	760
579-416-□◇	ST13□◇△-00800E	800	900	860
579-417-□◇	ST13□◇△-00900E	900	1000	960
579-418-□◇	ST13□◇△-01000E	1000	1100	1060
579-419-□◇	ST13□◇△-01100E	1100	1200	1160
579-420-□◇	ST13□◇△-01200E	1200	1300	1260
579-421-□◇	ST13□◇△-01300E	1300	1400	1360
579-422-□◇	ST13□◇△-01400E	1400	1500	1460
579-423-□◇	ST13□◇△-01500E	1500	1600	1560
579-424-□◇	ST13□◇△-01600E	1600	1700	1660
579-425-□◇	ST13□◇△-01700E	1700	1800	1760
579-426-□◇	ST13□◇△-01800E	1800	1900	1860
579-427-□◇	ST13□◇△-02000E	2000	2100	2060
579-428-□◇	ST13□◇△-02200E	2200	2300	2260
579-429-□◇	ST13□◇△-02400E	2400	2500	2460
579-430-□◇	ST13□◇△-02500E	2500	2600	2560
579-431-□◇	ST13□◇△-02600E	2600	2700	2660
579-432-□◇	ST13□◇△-02800E	2800	2900	2860
579-433-□◇	ST13□◇△-03000E	3000	3100	3060

*1: The □ mark in Code No. and Model number represents as follows:

- 0: Mitutoyo ENSIS® specifications Compatible with high-speed serial interface
- 4: Mitsubishi Electric Corporation specifications Compatible with high-speed serial interface
- 5: FANUC Corporation specifications Compatible with high-speed serial interface
- 7: Panasonic Corporation specifications Compatible with high-speed serial interface
- 8: Yaskawa Electric Corporation specifications Compatible with high-speed serial interface

4 Specifications

*2: The \diamond mark in Code No. and Model number represents as follows:

1: Resolution 0.01 μm

2: Resolution 0.001 μm

*3: The \triangle mark in Model number represents as follows:

A: Half duplex system

None: Full duplex system or full duplex system/half duplex system

4.7.4 Specifications for Fixing at the Center (Effective Length of 500 mm–2200 mm)

Dimensional drawings

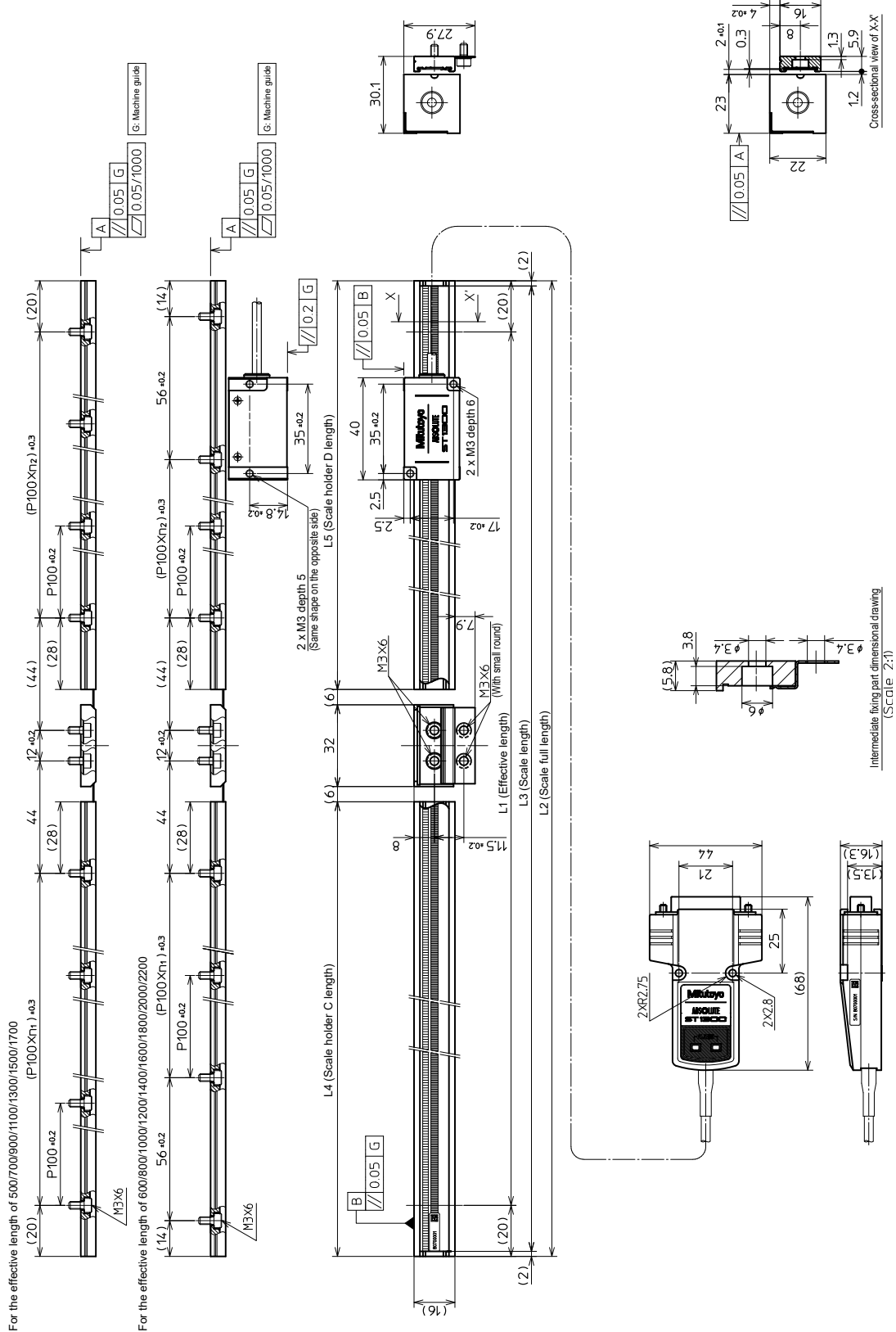

■ Dimensional drawings table

Code No. (*1, *2)	Model number (*1, *3, *4, *5)	Effective length L1 (mm)	Scale full length L2 (mm)	Scale length L3 (mm)	Scale holder C length L4 (mm)	Scale holder D length L5 (mm)	Number of scale holder C mounting holes n	Number of scale holder D mounting holes n	Total number of scale holder mounting holes
579-434-□◇	ST13□▽△-500☆	500	540	536	248	248	2	2	6
579-435-□◇	ST13□▽△-600☆	600	640	636	298	298	2	2	8
579-436-□◇	ST13□▽△-700☆	700	740	736	348	348	3	3	8
579-437-□◇	ST13□▽△-800☆	800	840	836	398	398	3	3	10
579-438-□◇	ST13□▽△-900☆	900	940	936	448	448	4	4	10
579-439-□◇	ST13□▽△-1000☆	1000	1040	1036	498	498	4	4	12
579-440-□◇	ST13□▽△-1100☆	1100	1140	1136	548	548	5	5	12
579-441-□◇	ST13□▽△-1200☆	1200	1240	1236	598	598	5	5	14
579-442-□◇	ST13□▽△-1300☆	1300	1340	1336	648	648	6	6	14
579-443-□◇	ST13□▽△-1400☆	1400	1440	1436	698	698	6	6	16
579-444-□◇	ST13□▽△-1500☆	1500	1540	1536	748	748	7	7	16
579-445-□◇	ST13□▽△-1600☆	1600	1640	1636	798	798	7	7	18
579-446-□◇	ST13□▽△-1700☆	1700	1740	1736	848	848	8	8	18
579-447-□◇	ST13□▽△-1800☆	1800	1840	1836	898	898	8	8	20
579-448-□◇	ST13□▽△-2000☆	2000	2040	2036	998	998	9	9	22
579-449-□◇	ST13□▽△-2200☆	2200	2240	2236	1098	1098	10	10	24

*1: The □ mark in Code No. and Model number represents as follows:

0: Mitutoyo ENSIS® specifications Compatible with high-speed serial interface

4: Mitsubishi Electric Corporation specifications Compatible with high-speed serial interface

5: FANUC Corporation specifications Compatible with high-speed serial interface

7: Panasonic Corporation specifications Compatible with high-speed serial interface

8: Yaskawa Electric Corporation specifications Compatible with high-speed serial interface

*2: The ◇ mark in Code No. represents as follows:

3: 0.01 μm (without the system parameters)

4: 0.001 μm (without the system parameters)

5: 0.01 μm (with the system parameters)

6: 0.001 μm (with the system parameters)

*3: The ▽ mark in Model number represents as follows:

1: Resolution 0.01 μm

2: Resolution 0.001 μm

*4: The △ mark in Model number represents as follows:

A: Half duplex system

None: Full duplex system or full duplex system/half duplex system

*5: The ☆ mark in Model number represents as follows:

F: Specifications for fixing at the center (without the system parameters)

G: Specifications for fixing at the center (with the system parameters)

■ Dimensional drawings table

Code No. (*1, *2)	Model number (*1, *3, *4, *5)	Effective length L1 (mm)	Scale full length L2 (mm)	Scale length L3 (mm)	Scale holder C length L4 (mm)	Scale holder D length L5 (mm)	Scale holder E length L6 (mm)	Number of scale holder C mounting holes n	Number of scale holder D mounting holes n	Number of scale holder E mounting holes n	Total number of scale holder mounting holes
579-450-□◇	ST13□▽△-2400☆	2400	2440	2436	240	198	956	1	1	9	28
579-451-□◇	ST13□▽△-2500☆	2500	2540	2536	290	248	956	2	2	9	28
579-452-□◇	ST13□▽△-2600☆	2600	2640	2636	240	298	1056	1	2	10	30
579-453-□◇	ST13□▽△-2800☆	2800	2840	2836	440	398	956	3	3	9	32
579-454-□◇	ST13□▽△-3000☆	3000	3040	3036	440	498	1056	3	4	10	34
579-455-□◇	ST13□▽△-3200☆	3200	3240	3236	640	598	956	5	5	9	36
579-456-□◇	ST13□▽△-3400☆	3400	3440	3436	640	698	1056	5	6	10	38
579-457-□◇	ST13□▽△-3600☆	3600	3640	3636	840	798	956	7	7	9	40
579-458-□◇	ST13□▽△-3800☆	3800	3840	3836	840	898	1056	7	8	10	42
579-459-□◇	ST13□▽△-4000☆	4000	4040	4036	1040	998	956	9	9	9	44
579-460-□◇	ST13□▽△-4200☆	4200	4240	4236	1040	1098	1056	9	10	10	46

*1: The □ mark in Code No. and Model number represents as follows:

0: Mitutoyo ENSIS® specifications Compatible with high-speed serial interface

4: Mitsubishi Electric Corporation specifications Compatible with high-speed serial interface

5: FANUC Corporation specifications Compatible with high-speed serial interface

7: Panasonic Corporation specifications Compatible with high-speed serial interface

8: Yaskawa Electric Corporation specifications Compatible with high-speed serial interface

*2: The ◇ mark in Code No. represents as follows:

3: 0.01 μm (without the system parameters)

4: 0.001 μm (without the system parameters)

5: 0.01 μm (with the system parameters)

6: 0.001 μm (with the system parameters)

*3: The ▽ mark in Model number represents as follows:

1: Resolution 0.01 μm

2: Resolution 0.001 μm

*4: The △ mark in Model number represents as follows:

A: Half duplex system

None: Full duplex system or full duplex system/half duplex system

*5: The ☆ mark in Model number represents as follows:

F: Specifications for fixing at the center (without the system parameters)

G: Specifications for fixing at the center (with the system parameters)

4.7.6 Specifications for Fixing at the Center (Effective Length of 4400 mm–6000 mm)

■ Dimensional drawings

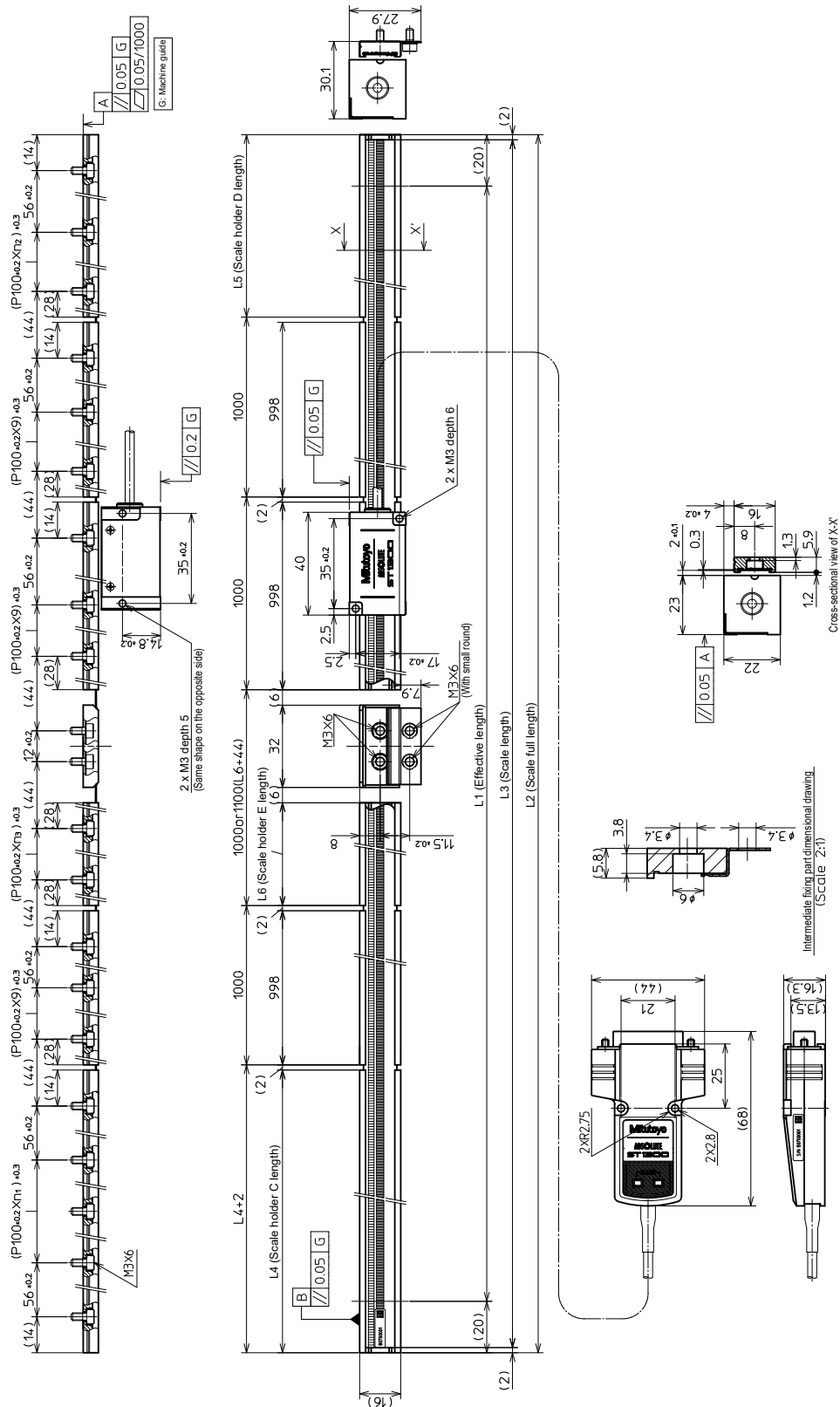

■ Dimensional drawings table

Code No. (*1, *2)	Model number (*1, *3, *4, *5)	Effective length L1 (mm)	Scale full length L2 (mm)	Scale length L3 (mm)	Scale holder C length L4 (mm)	Scale holder D length L5 (mm)	Scale holder E length L6 (mm)	Number of scale holder C mounting holes n	Number of scale holder D mounting holes n	Number of scale holder E mounting holes n	Total number of scale holder mounting holes
579-461-□◇	ST13□▽△-4400☆	4400	4440	4436	240	198	956	1	1	9	50
579-462-□◇	ST13□▽△-4600☆	4600	4640	4636	240	298	1056	1	2	10	52
579-463-□◇	ST13□▽△-4800☆	4800	4840	4836	440	398	956	3	3	9	54
579-464-□◇	ST13□▽△-5000☆	5000	5040	5036	440	498	1056	3	4	10	56
579-465-□◇	ST13□▽△-5200☆	5200	5240	5236	640	598	956	5	5	9	58
579-466-□◇	ST13□▽△-5400☆	5400	5440	5436	640	698	1056	5	6	10	60
579-467-□◇	ST13□▽△-5600☆	5600	5640	5636	840	798	956	7	7	9	62
579-468-□◇	ST13□▽△-5800☆	5800	5840	5836	840	898	1056	7	8	10	64
579-469-□◇	ST13□▽△-6000☆	6000	6040	6036	1040	998	956	9	9	9	66

*1: The □ mark in Code No. and Model number represents as follows:

0: Mitutoyo ENSIS® specifications Compatible with high-speed serial interface

4: Mitsubishi Electric Corporation specifications Compatible with high-speed serial interface

5: FANUC Corporation specifications Compatible with high-speed serial interface

7: Panasonic Corporation specifications Compatible with high-speed serial interface

8: Yaskawa Electric Corporation specifications Compatible with high-speed serial interface

*2: The ◇ mark in Code No. represents as follows:

3: 0.01 μm (without the system parameters)

4: 0.001 μm (without the system parameters)

5: 0.01 μm (with the system parameters)

6: 0.001 μm (with the system parameters)

*3: The ▽ mark in Model number represents as follows:

1: Resolution 0.01 μm

2: Resolution 0.001 μm

*4: The △ mark in Model number represents as follows:

A: Half duplex system

None: Full duplex system or full duplex system/half duplex system

*5: The ☆ mark in Model number represents as follows:

F: Specifications for fixing at the center (without the system parameters)

G: Specifications for fixing at the center (with the system parameters)

MEMO

5 Troubleshooting

This chapter describes how to check the causes for the trouble at the initial power-on, or for the alarm sounded during operation.

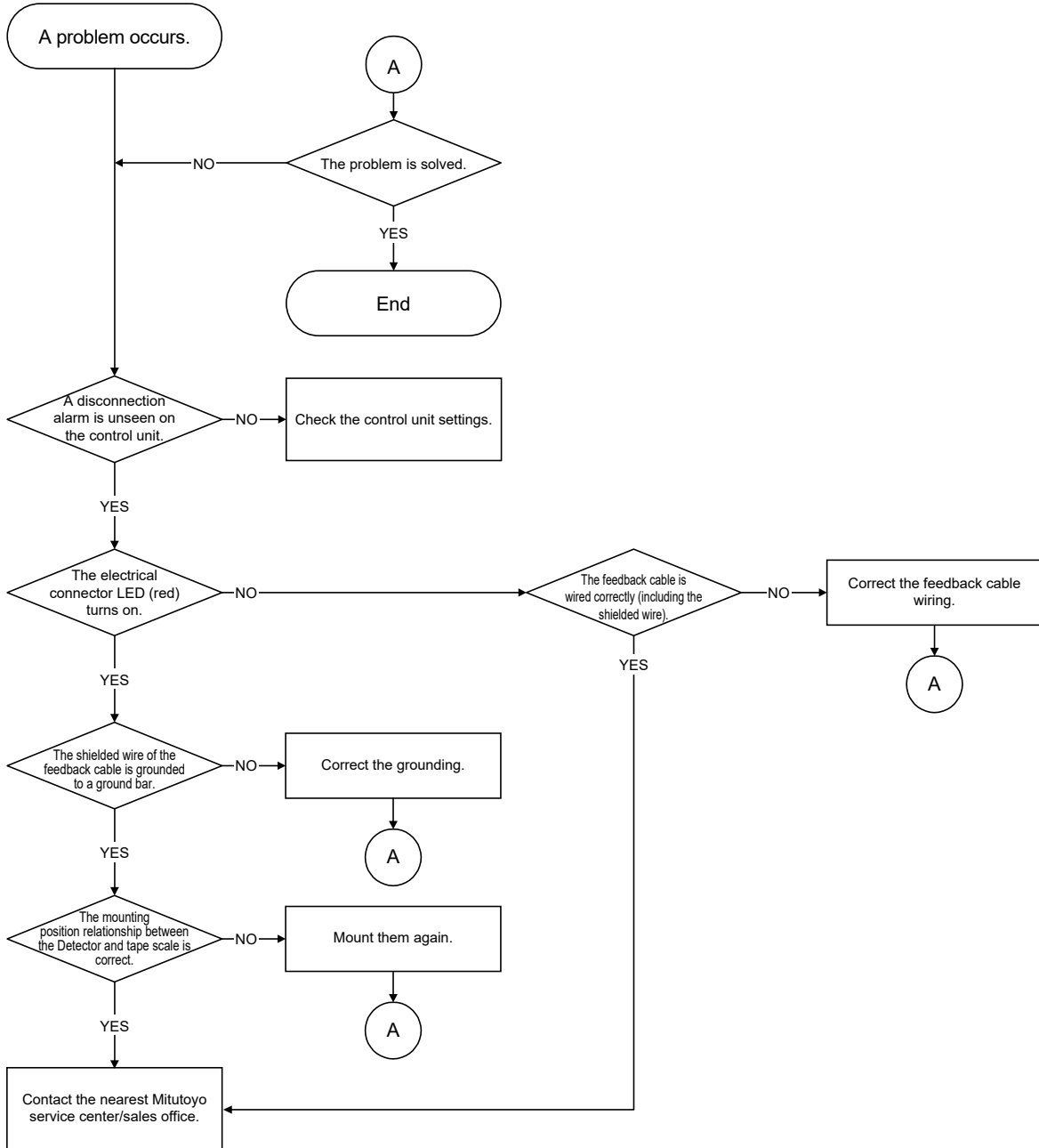

MEMO

SERVICE NETWORK

*As of October 2020

Europe

Mitutoyo Europe GmbH

Borsigstrasse 8-10, 41469 Neuss, GERMANY
TEL: 49 (0)2137 102-0 FAX: 49 (0)2137 102-351

Mitutoyo CTL Germany GmbH

Von-Gunzert-Strasse 17, 78727 Oberndorf, GERMANY
TEL: 49 (0)7423 8776-0 FAX: 49 (0)7423 8776-99

KOMEG Industrielle Messtechnik GmbH

Zum Wasserwerk 3, 66333 Völklingen, GERMANY
TEL: 49 (0)6898 91110 FAX: 49 (0)6898 911100

Germany

Mitutoyo Deutschland GmbH

Borsigstrasse 8-10, 41469 Neuss, GERMANY
TEL: 49 (0)2137 102-0 FAX: 49 (0)2137 86 85

M³ Solution Center Hamburg

Tempowerkring 9-im HIT-Technologiepark 21079
Hamburg, GERMANY
TEL: 49 (0)40 791894-0 FAX: 49 (0)40 791894-50

M³ Solution Center Berlin

Ernst-Lau-Straße 6, 12489 Berlin, GERMANY
TEL:49(0)30 2611 267 FAX: 49 30 67988729

M³ Solution Center Eisenach

Neue Wiese 4, 99817 Eisenach,GERMANY
TEL: 49 (0)3691 88909-0 FAX: 49 (0)3691 88909-9

M³ Solution Center Ingolstadt

Marie-Curie-Strasse 1A, 85055 Ingolstadt, GERMANY
TEL: 49 (0)841 954920 FAX: 49 (0)841 9549250

M³ Solution Center Leonberg

Steinbeisstrasse 2, 71229 Leonberg, GERMANY
TEL: 49 (0)7152 6080-0 FAX: 49 (0)7152 608060

Mitutoyo-Messgeräte Leonberg GmbH

Heidenheimer Strasse 14, 71229 Leonberg, GERMANY
TEL: 49 (0)7152 9237-0 FAX: 49 (0)7152 9237-29

U.K.

Mitutoyo (UK) Ltd.

Joule Road, West Point Business Park,
Andover, Hampshire SP10 3UX, UNITED KINGDOM
TEL: 44 (0)1264 353 123 FAX: 44 (0)1264 354883

M³ Solution Center Coventry

Unit6, Banner Park, Wickmans Drive, Coventry,
Warwickshire CV4 9XA, UNITED KINGDOM
TEL: 44 (0)2476 426300 FAX: 44 (0)2476 426339

M³ Solution Center Halifax

Lowfields Business Park, Navigation Close, Elland,
West Yorkshire HX5 9HB, UNITED KINGDOM
TEL: 44 (0)1422 375566 FAX: 44 (0)1422 328025

M³ Solution Center East Kilbride

The Baird Building, Rankine Avenue, Scottish
Enterprise Technology Park, East Killbride G75
0QF, UNITED KINGDOM
TEL: 44 (0)1355 581170 FAX: 44 (0)1355 581171

France

Mitutoyo France

Paris Nord 2-123 rue de la Belle Etoile, BP 59267
ROISSY EN FRANCE 95957 ROISSY CDG
CEDEX, FRANCE
TEL: 33 (0)149 38 35 00

M³ Solution Center LYON

Parc Mail 523, cours du 3ème millénaire, 69791
Saint-Priest, FRANCE
TEL: 33 (0)149 38 35 70

M³ Solution Center STRASBOURG

Parc de la porte Sud, Rue du pont du péage,
67118 Geispolsheim, FRANCE
TEL: 33 (0)149 38 35 80

M³ Solution Center CLUSES

Espace Scionzier 480 Avenue des Lacs, 74950
Scionzier, FRANCE
TEL: 33 (0)1 49 38 35 90

M³ Solution Center TOULOUSE

Aeroparc Saint Martin Cellule B08 ZAC de Saint
Martin du Touch 12 rue de Caulet 31300
Toulouse, FRANCE
TEL: 33 (0)1 49 38 42 90

M³ Solution Center RENNES

2, rue Claude Chappe, PA le Vallon - ZAC
Mivoie, 35230 Noyal-Châtillon-sur-Seiche,
FRANCE
TEL: 33 (0)1 49 38 42 10

Italy

MITUTOYO ITALIANA S.r.l.

Corso Europa, 7 - 20045 Lainate (MI), ITALY
TEL: 39 02 935781 FAX: 39 02 93578255

M³ Solution Center BOLOGNA

Via dei Carpini1/A - 40011 Anzola Emilia (BO), ITALY
TEL: 39 02 93578215 FAX: 39 02 93578255

M³ Solution Center CHIETI

Contrada Santa Calcagna - 66020 Rocca S. Giovanni (CH), ITALY
TEL: 39 02 93578280 FAX: 39 02 93578255

M³ Solution Center PADOVA

Via G. Galilei 21/F - 35035 Mestrino (PD), ITALY
TEL: 39 02 93578268 FAX: 39 02 93578255

Netherlands

Mitutoyo Nederland B.V.

Wiltonstraat 25, 3905 KW Veenendaal,
THE NETHERLANDS
TEL: 31(0)318-534911

Mitutoyo Nederland B.V. / M³ Solution Center Enschede

Institutenweg 50, 7521 PK Enschede,
THE NETHERLANDS
TEL: 31(0)318-534911

Mitutoyo Nederland B.V. / M³ Solution Center Eindhoven

De Run 1115, 5503 LB Veldhoven,
THE NETHERLANDS
TEL: 31(0)318-534911

Mitutoyo Research Center Europe B.V.

De Rijn 18, 5684 PJ Best, THE NETHERLANDS
TEL:31(0)499-320200 FAX:31(0)499-320299

Belgium

Mitutoyo Belgium N.V. / M³ Solution Center Melsele

Schaarbeekstraat 20, B-9120 Melsele, BELGIUM
TEL: 32 (0)3-2540444

Sweden

Mitutoyo Scandinavia AB

Släntvägen 6, 194 61 Upplands Väsby, SWEDEN
TEL: 46 (0)8 594 109 50 FAX: 46 (0)8 590 924 10

M³ Solution Center Alingsås

Ängsvaktaregatan 3A, 441 38 Alingsås, SWEDEN
TEL: 46 (0)8 594 109 50 FAX:46 (0)322 63 31 62

M³ Solution Center Värnamo

Storgatsbacken 1, 331 30 Värnamo, SWEDEN
TEL: 46 (0)8 594 109 50 FAX: 46 (0)370 463 34

Switzerland

Mitutoyo (Schweiz) AG

Steinackerstrasse 35, 8902 Urdorf, SWITZERLAND
TEL: 41 (0)447361150 FAX: 41(0)447361151

Mitutoyo (Suisse) SA

Rue Galilée 4, 1400 Yverdon-les Bains, SWITZERLAND
TEL: 41 (0)244259422 FAX: 41 (0)447361151

Poland

Mitutoyo Polska Sp.z o.o.

Ul.Graniczna 8A, 54-610 Wroclaw, POLAND
TEL: 48 (0)71354 83 50 FAX: 48 (0)71354 83 55

Czech Republic

Mitutoyo Česko s.r.o.

Dubská 1626, 415 01 Teplice, CZECH REPUBLIC
TEL: 420 417-514-011 FAX: 420 417-579-867

Mitutoyo Česko s.r.o. M³ Solution Center Ivančice

Ke Karlovu 62/10, 664 91 Ivančice, CZECH REPUBLIC
TEL: 420 417-514-011 FAX: 420 417-579-867

Mitutoyo Česko s.r.o. M³ Solution Center Ostrava Mošnov

Mošnov 314, 742 51 Mošnov, CZECH REPUBLIC
TEL: 420 417-514-050 FAX:420 417-579-867

Mitutoyo Česko s.r.o. Slovakia Branch

Hviezdoslavova 124, 017 01 Povážská Bystrica, SLOVAKIA
TEL: 421 948-595-590

Hungary

Mitutoyo Hungária Kft.

Záhony utca 7, D-épület / fsz, 1031 Budapest, HUNGARY
TEL: 36 (0)1 2141447 FAX: 36 (0)1 2141448

Romania

Mitutoyo Romania SRL

1A Drumul Garii Odai Street, showroom, Ground Floor, 075100 OTOPENI-ILFOV, ROMANIA
TEL: 40 (0)311012088 FAX: +40 (0)311012089

Showroom in Brasov

Strada Ionescu Crum Nr.1, Brasov Business Park Turnul 1, Mezanin, 500446 Brasov-Judetul Brasov, ROMANIA
TEL/FAX: 40 (0)371020017

Russian Federation**Mitutoyo RUS LLC**

13 Sharikopodshipnikovskaya, bld.2,
115088 Moscow, RUSSIAN FEDERATION
TEL: 7 495 7450 752

Finland**Mitutoyo Scandinavia AB Finnish Branch**

Viherkiiitäjä 2A, 33960, Pirkkala, FINLAND
TEL: 358 (0)40 355 8498

Austria**Mitutoyo Austria GmbH**

Salzburger Straße 260 / 3 A-4600 Wels, AUSTRIA
TEL: 43 (0)7242 219 998

Mitutoyo Austria GmbH Goetzis Regional showroom

Lastenstrasse 48a 6840 Götzis AUSTRIA

Singapore**Mitutoyo Asia Pacific Pte. Ltd.****Head office / M³ Solution Center**

24 Kallang Avenue, Mitutoyo Building,
SINGAPORE 339415
TEL:(65)62942211 FAX:(65)62996666

Malaysia**Mitutoyo (Malaysia) Sdn. Bhd.****Kuala Lumpur Head Office / M³ Solution Center**

Mah Sing Integrated Industrial Park, 4, Jalan Utarid U5/14,
Section U5, 40150 Shah Alam, Selangor, MALAYSIA
TEL:(60)3-78459318 FAX:(60)3-78459346

Penang Branch office / M³ Solution Center

30, Persiaran Mahsuri 1/2, Sunway Tunas, 11900
Bayan Lepas, Penang, MALAYSIA
TEL:(60)4-6411998 FAX:(60)4-6412998

Johor Branch office / M³ Solution Center

70 (Ground Floor), Jalan Molek 1/28, Taman
Molek, 81100 Johor Bahru, Johor, MALAYSIA
TEL:(60)7-3521626 FAX:(60)7-3521628

Thailand**Mitutoyo(Thailand)Co., Ltd.****Bangkok Head Office / M³ Solution Center**

76/3-5, Chaengwattana Road, Kwaeng Anusaowaree,
Khet Bangkaen, Bangkok 10220, THAILAND
TEL:(66)2080 3500 FAX:(66)2521 6136

Chonburi Branch / M³ Solution Center

7/1, Moo 3, Tambon Bowin, Amphur Sriracha,
Chonburi 20230, THAILAND
TEL:(66)2080 3563 FAX:(66)3834 5788

ACC Branch / M³ Solution Center

122/8, 122/9, Moo 6, Tambon Donhuaroh, Amphur
Muangchonburi, Chonburi 20000, THAILAND
TEL:(66)2080 3565

Indonesia**PT. Mitutoyo Indonesia****Head Office / M³ Solution Center**

Jalan Sriwijaya No.26 Desa cibatu Kec. Cikarang
Selatan Kab. Bekasi 17530, INDONESIA
TEL: (62)21-2962 8600 FAX: (62)21-2962 8604

Vietnam**Mitutoyo Vietnam Co., Ltd****Hanoi Head Office / M³ Solution Center**

1st & 2nd floor, MHDl Building, No. 60 Hoang Quoc
Viet Road, Nghia Do Ward, Cau Giay District, Hanoi,
VIETNAM

TEL:(84)24-3768-8963 FAX:(84)24-3768-8960

Ho Chi Minh City Branch Office / M³ Solution Center

123 Dien Bien Phu Street, Ward 15, Binh Thanh
District, Ho Chi Minh City, VIETNAM

TEL:(84)28-3840-3489 FAX:(84)28-3840-3498

Philippines**Mitutoyo Philippines, Inc.****Head Office / M³ Solution Center**

Unit 1B & 2B LTI, Administration Building 1, Annex 1, North
Main Avenue, Laguna Technopark, Binan Laguna 4024,
PHILIPPINES

TEL:(63)49 544 0272 FAX:(63)49 544 0272

India**Mitutoyo South Asia Pvt. Ltd. Head Office**

C-122, Okhla Industrial Area, Phase-I,
New Delhi-110 020, INDIA

TEL:(91) 11-26372090 FAX: (91) 11-26372636

MSA Technical Center

Plot no. 65, Ground Floor, Udyog Vihar, Phase-4 Gurga-
on, Haryana - 122016, INDIA

TEL : (91) 124-2340286/287

Mumbai Region Head office

303, Sentinel Hiranandani Business Park Powai,
Mumbai-400 076, INDIA

TEL:(91) 22-25700684/837/839 FAX: (91) 22-25700685

Pune Office / M³ Solution Center

G4/G5, Pride Kumar Senate, Off. Senapati Bapat
Road, Pune-411 016, INDIA

TEL:(91) 20-25660043/44/45 FAX: (91) 20-66033644

Bengaluru Region Head office / M³ Solution Center

No. 5, 100 Ft. Road, 17th Main, Koramangala,
4th Block, Bengaluru-560 034, INDIA
TEL:(91) 80-25630946/47/48 FAX: (91) 80-25630949

Chennai Office / M³ Solution Center

No. 624, Anna Salai Teynampet, Chennai-600 018, INDIA
TEL: (91) 44-24328823/24
FAX: (91) 44-24328825

Kolkata Office

Unit No. 1208,Om Tower, 32,J.L..Nehru Road,
Kolkata-700 071, INDIA
Tel: 91 33-22267088/40060635 Fax: (91) 33-22266817

Ahmedabad Office/M³ Solution Center (Ahmedabad)

A-104 & A-105, First Floor, Solitaire Corporate
Park, Near Divya Bhaskar Press, S.G. Road,
Ahmedabad - 380 015, INDIA
TEL: (91) 079 - 29704902/903

Coimbatore Office

Regus, Srivari Srimath, 3rd Floor, Door No:1045,
Avinashi Road, Coimbatore - 641 018,INDIA
TEL: (91) 9345005663

Taiwan

Mitutoyo Taiwan Co., Ltd. / M³ Solution Center Taipei
4F., No.71, Zhouzi St., Neihu Dist.,Taipei City 114,
TAIWAN (R.O.C.)

TEL:886(2)5573-5900 FAX:886(2)8752-3267

Taichung Branch / M³ Solution Center Taichung

1F., No. 299, Gaotie 1st Rd., Wuri Dist., Taichung
City 414, TAIWAN (R.O.C.)

TEL:886(4)2338-6822 FAX:886(4)2338-6722

Kaohsiung Branch / M³ Solution Center Kaohsiung

1F., No.31-1, Haibian Rd., Lingya Dist.,
Kaohsiung City 802, TAIWAN (R.O.C.)

TEL:886(7)334-6168 FAX:886(7)334-6160

South Korea**Mitutoyo Korea Corporation****Head Office / M³ Solution Center**

(Sanbon-Dong, Geumjeong High View Build.), 6F, 153-8,
Ls-Ro, Gunpo-Si, Gyeonggi-Do, 15808 KOREA

TEL:82(31)361-4200 FAX:82(31)361-4201

Busan Office / M³ Solution Center

(3150-3, Daejeo 2-dong) 8,Yutongdanji 1-ro
49beon-gil, Gangseo-gu, Busan, 46721 KOREA

TEL:82(51)324-0103 FAX:82(51)324-0104

Daegu Office / M³ Solution Center

(Galsan-dong, Daegu Business Center), 301-Ho, 217,
Seongseogongdan-ro, Dalseo-gu, Daegu 42704 KOREA

TEL:82(53)593-5602 FAX:82(53)593-5603

China**Mitutoyo Measuring Instruments (Shanghai) Co., Ltd.**

8th Floor, Tower 1 Lujiazui Jinkong Square
No.1788/1800 Century Ave., Pudong New Dis-
trict, Shanghai 200122, CHINA

TEL:86(21)5836-0718 FAX:86(21)5836-0717

Suzhou Office / M³ Solution Center (Suzhou)

No. 46 Baiyu Road, Suzhou 215021, CHINA

TEL:86(512)6522-1790 FAX:86(512)6251-3420

Wuhan Office / M³ Solution Corner

Room 1701, Wuhan Wanda Center, No. 96,
Linjiang Road, Wuchang District, Wuhan
Hubei 430060, CHINA

TEL:86(27)8544-8631 FAX:86(27)8544-6227

Chengdu Office

1-701, New Angle Plaza, 668# Jindong Road,
Jinjiang District, Chengdu, Sichuan 610066,CHINA

TEL:86(28)8671-8936 FAX:86(28)8671-9086

Hangzhou Office

Room 804, Eastern International Business Cen-
ter Building 1, No.600 Jinsha Road of

Hangzhou Economic and Technological
Development Zone, 310018, CHINA

TEL: 86(571)8288-0319 FAX: 86(571)8288-0320

Tianjin Office / M³ Solution Center China (Tianjin)

Room D 12/F, TEDA Building, No.256 Jie-fang
Nan Road Hexi District,Tianjin 300042, CHINA

TEL:86(22)5888-1700 FAX:86(22)5888-1701

Changchun Office

Room 815, 8F, Building A1, Upper East
International No.3000 Dongsheng Street,
Erdao District, Changchun, Jilin, 130031, CHINA

TEL:86(431)8192-6998 FAX:86(431)8192-6998

Chongqing Office

Room 1312, Building 3, Zhongyu Plaza, No.86,
Hongjin Avenue,Longxi Street, Yubei District,
Chongqing, 400000, CHINA

TEL:86(23)6595-9950 FAX:86(23)6595-9950

Qingdao Office

Room 638, 6F, No.192 Zhengyang Road, Chengyang
District, Qingdao, Shandong, 266109, CHINA

TEL:86(532)8096-1936 FAX:86(532)8096-1937

Xi'an Office

Room 805, Xi'an International Trade Center, No.
196 Xiaozhai East Road, Xi'an, 710061, CHINA

TEL:86(29)8538-1380 FAX:86(29)8538-1381

Dalian Office / M³ Solution Center China (Dalian)

Room A-106 Shuijing SOHO, No.16 Harbin Road, Economic Development Zone, Dalian, 116600 CHINA
TEL:86(411)8718 1212 FAX:86(411)8754-7587

Zhengzhou Office

Room1801,18/F,Unit1,Building No.23, Shangwu Inner Ring Road, Zhengdong New District,Zhengzhou City, Henan 450018, CHINA
TEL:86(371)6097-6436 FAX:86(371)6097-6981

Dongguan Office / M³ Solution Center China (Dongguan)

No.26, Chang'an Section Guanchang Road, Chang'an Town, Dongguan City, Guangdong 523855, CHINA
TEL:86(769)8541 7715 FAX:86(769)-8541 7745

Fuzhou Office

Room 2104, City Commercial Centre, No.129 Wu Yi Road N., Fuzhou City, Fujian 350005, CHINA
TEL 86 (591) 8761 8095
FAX 86 (591) 8761 8096

Changsha Office

Room 2207, Building 1, Shiner International Plaza, No. 88, Kaiyuan Middle Road, Changsha City, Hunan 410100, CHINA
TEL 86 (731) 8401 9276
FAX 86 (731) 8401 9376

Mitutoyo Leeport Metrology (Hong Kong) Limited

Room 818, 8/F, Vanta Industrial Centre, No.21-33, Tai Lin Pai Road, Kwai Chung, NT, HONG KONG
TEL:(852)2992-2088 FAX:(852)2670-2488

Mitutoyo Measuring Instruments (Suzhou) Co., Ltd.

No. 46 Baiyu Road, Suzhou 215021, CHINA
TEL:86(512)6252-2660 FAX:86(512)6252-2580

U.S.A.

Mitutoyo America Corporation

965 Corporate Blvd., Aurora, IL 60502, U.S.A.
TEL:1-(630)820-9666 Toll Free No. 1-888-648-8869
FAX:1-(630)978-3501

M³ Solution Center-Illinois

965 Corporate Blvd., Aurora, IL 60502, U.S.A.

M³ Solution Center-Ohio

6220 Hi-Tek Ct., Mason, OH 45040, U.S.A.
TEL:1-(888)-648-8869 FAX:1-(513)754-0718

M³ Solution Center-Michigan

46850 Magellan Drive, Suite 100 Novi, MI 48377, U.S.A.
TEL:1-(888)-648-8869 FAX: 1-(248)-926-0928

M³ Solution Center-California

16925 E. Gale Ave., City of Industry, CA 91745, U.S.A.
TEL:1-(888)-648-8869 FAX:1-(626)369-3352

M³ Solution Center-North Carolina

11515 Vanstory Dr., Suite 140, Huntersville, NC 28078, U.S.A.
TEL:1-(888)-648-8869 FAX:1-(704)875-9273

M³ Solution Center-Alabama

2100 Riverchase Center Suite 106, Birmingham, AL 35244, U.S.A
TEL:1-(888)-648-8869 FAX:1-(205)-988-3423

M³ Solution Center-Washington

1000 SW 34th St. Suite G, Renton, WA 98057 U.S.A.
TEL:1-(888)-648-8869

M³ Solution Center-Texas

4560 Kendrick Plaza Drive Suite 120 Houston, TX 77032, U.S.A.
TEL:1-(888)-648-8869 FAX:1-(281)227-0937

M³ Solution Center-Massachusetts

753 Forest Street, Suite 110, Marlborough, MA 01752, U.S.A.
TEL:1-(888)648-8869 FAX:1-(508)485-0782

Mitutoyo America Corporation Calibration Lab

965 Corporate Blvd., Aurora, IL 60502, U.S.A.
TEL:1-(888)-648-8869 FAX:1-(630)978-6477

Micro Encoder, Inc.

11533 NE 118th St., Kirkland, WA 98034-7111, U.S.A.
TEL:1-(425)821-3906 FAX:1-(425)821-3228

Micro Encoder Los Angeles, Inc.

16925 Gale Ave. City of Industry, CA 91745-1806 U.S.A.
TEL: 1-626-961-9661 FAX:1-626-333-8019

Mitutoyo America Corporation CT-Lab Chicago

965 Corporate Blvd., Aurora, IL 60502, U.S.A.
TEL: 1-(888)-648-8869 FAX: 1-(630)-820-3418

Canada

Mitutoyo Canada Inc.

2121 Meadowvale Blvd., Mississauga,
Ont. L5N 5N1., CANADA
TEL:1-(905)821-1261 FAX:1-(905)821-4968

Montreal Office

7075 Place Robert-Joncas Suite 129, Montreal,
Quebec H4M 2Z2, CANADA
TEL:1-(514)337-5994 FAX:1-(514)337-4498

Brazil

Mitutoyo Sul Americana Ltda.

Head office / M³ Solution Center / Factory

Rodovia Índio Tibiriçá 1555, CEP 08655-000 -
Vila Sol Nascente - Suzano - SP - BRASIL
TEL:55 (11)5643-0040

Argentina

Mitutoyo Sul Americana Ltda.

Argentina Branch / M³ Solution Center

Av. B. Mitre 891/899 – C.P. (B1603CQI)
Vicente López –Pcia. Buenos Aires – ARGENTINA
TEL:54(11)4730-1433 FAX:54(11)4730-1411

Sucursal Cordoba / M³ Solution Center

Av. Amadeo Sabattini, 1296, esq. Madrid B^o
Crisol Sur – CP 5000, Cordoba, ARGENTINA
TEL/FAX:54 (351) 456-6251

Mexico

Mitutoyo Mexicana, S.A. de C.V.

Industria Eléctrica No.15, Parque Industrial, Nau-
calpan de Juárez, Estado de México C.P.53370,
MÉXICO
TEL: 52 (01-55) 5312-5612
FAX: 52 (01-55) 5312-3380

Monterrey Office / M³ Solution Center

Blv. Interamericana No. 103, Parque Industrial
FINSA, C.P. 66636 Apodaca, N.L., MÉXICO
TEL: 52(01-81) 8398-8227/8228/8242/8244
FAX: 52(01-81) 8398-8226

Tijuana Office / M³ Solution Center

Calle José María Velazco 10501-C, Col. Cd. Industrial
Nueva Tijuana, C.P. 22500 Tijuana, B.C., MÉXICO
TEL: 52 (01-664) 647-5024

Querétaro Office / M³ Solution Center

Av. Cerro Blanco No.500-1, Colonia Centro Sur,
Querétaro, Querétaro, C.P. 76090, MÉXICO
TEL: 52 (01-442) 340-8018, 340-8019 and 340-8020
FAX: 52 (01-442) 340-8017

Mitutoyo Mexicana, S.A. de C.V. Querétaro Calibration Laboratory

Av. Cerro Blanco 500 30 Centro Sur,
Querétaro, Querétaro, C.P. 76090, MÉXICO
TEL: 52 (01-442) 340-8018, 340-8019 and 340-8020
FAX: 52 (01-442) 340-8017

Aguascalientes Office / M³ Solution Center

Av. Aguascalientes No. 622, Local 15 Centro Comer-
cial El Cilindro Fracc. Pulgas Pandas Norte, C.P.
20138, Aguascalientes, Ags. MÉXICO
TEL: 52 (01-449) 174-4140 and 174-4143

Irapuato Office / M³ Solution Center

Boulevard a Villas de Irapuato No. 1460 L.1 Col. Ejido
Irapuato C.P. 36643
Irapuato, Gto., MÉXICO
TEL: 52 (01-462) 144-1200 and 144-1400

Revision Record

Date of publication	Revision status	Details of revision
August 1, 2019	Third edition	Completely revised and issued
January 1, 2021	Fourth edition	Revision due to changes of the harmonized European standards, etc.

Mitutoyo Corporation

20-1, Sakado 1-Chome, Takatsu-ku, Kawasaki-shi, Kanagawa 213-8533, Japan
Tel: +81 (0)44 813-8230 Fax: +81 (0)44 813-8231
Home page: <http://www.mitutoyo.co.jp/global.html>

For the EU Directive, Authorized representative and importer in the EU:
Mitutoyo Europe GmbH
Borsigstrasse 8-10, 41469 Neuss, Germany

Printed in Japan

No. 99MBE084B